

High Path Accuracy Robot MOTOMAN-GA50

Application: Laser cutting and welding
30 kg (50 kg max.) payload, 6-axis vertically articulated

Robot Controller YRC1000

**Achieves high path accuracy through higher rigidity.
Yaskawa's optimal robot for laser cutting and welding**

High performance

- With optimal motors and a highly-rigid arm design, MOTOMAN-GA50 achieves small circle and linear cutting and welding with high speed and high accuracy.
- With the high payload, the robot can easily handle a variety of laser heads.
- With the maximum reach of 2038 mm, the robot can cut and weld various automobile parts.

Reduced wiring time

- Power cable is reduced to one cable, which reduces wiring time.

Smaller, energy-saving controller

- Smallest size in the world reduces installation space
- Global standardization (Universal size)
- Lighter programming pendant with better operability
- Energy savings with the power regeneration function [Electric power consumption reduced by a maximum of 30%* (compared with the former model)]

*: Depends on applications and motion patterns.



MOTOMAN-GA50



YRC1000

■ Dimensions Units: mm []: P-point Maximum Envelope

Note: Refer to the dimension diagram for detailed dimensions and specifications.

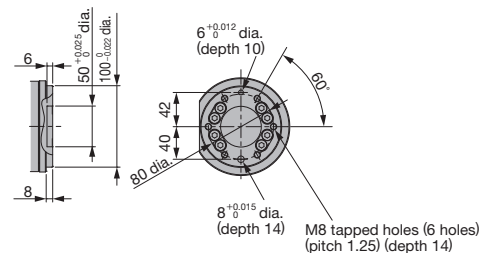
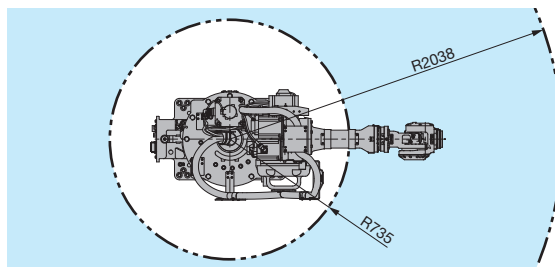

View A

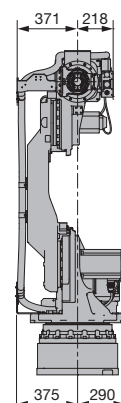
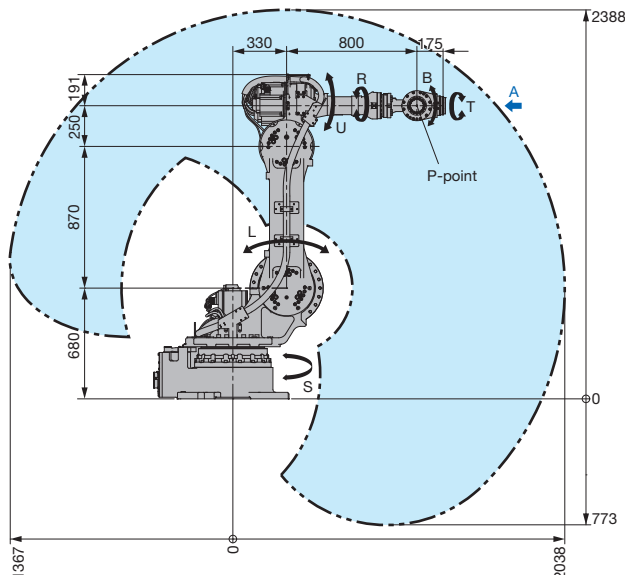

MOTOMAN-GA50

Manipulator Specifications

Model		MOTOMAN-GA50
Type		YR-1-06VXA50-A00
Controlled Axis		6 (vertically articulated)
Payload	Wrist	50 kg**
	U-arm	10 kg
Maximum Reach		2038 mm
Repeatability*1		0.015 mm
Range of Motion	S-axis (turning)	-180° – +180°
	L-axis (lower arm)	-90° – +135°
	U-axis (upper arm)	-80° – +180°
	R-axis (wrist roll)	-360° – +360°
	B-axis (wrist pitch/yaw)	-125° – +125°
	T-axis (wrist twist)	-360° – +360°
Maximum Speed*2	S-axis (turning)	2.62 rad/s, 150°/s
	L-axis (lower arm)	2.62 rad/s, 150°/s
	U-axis (upper arm)	2.62 rad/s, 150°/s
	R-axis (wrist roll)	4.36 rad/s, 250°/s
	B-axis (wrist pitch/yaw)	4.36 rad/s, 250°/s
	T-axis (wrist twist)	4.36 rad/s, 250°/s
Allowable Moment	R-axis (wrist roll)	110 N·m
	B-axis (wrist pitch/yaw)	110 N·m
	T-axis (wrist twist)	55 N·m
Allowable Inertia (GD ² /4)	R-axis (wrist roll)	7 kg·m ²
	B-axis (wrist pitch/yaw)	7 kg·m ²
	T-axis (wrist twist)	1 kg·m ²
Approx. Mass		855 kg
IEC Protection Class		Body: IP54, Wrist: IP67
Ambient Conditions	Temperature	0 °C to +45 °C
	Humidity	20% to 80%RH (non-condensing)
	Vibration	4.9 m/s ² (0.5 G) or less
	Altitude	1000 m or less
Power Requirements*3		3.5 kVA
Mounting		Floor

*1: Repeatability conforms to ISO 9283.

*2: The maximum speed in this table is the available maximum value and will vary depending on the load, posture, or range of motion.

*3: The power requirement value is obtained using Yaskawa's in-house measurement conditions and will vary depending on the load, motion pattern, or cycle time.

*4: A load of 30 kg or less is recommended for applications that require high accuracy.

YRC1000 Robot Controller Specifications

Items	Specifications
Configuration	Dust proof structure IP54 (area of backside duct fan: IP2X)
Dimensions	598 (W)×427 (D)×490 (H) mm, 125 L
Approx. Mass	85 kg max. (External axis amplifiers for up to three axes can be built in.)
Cooling System	Indirect cooling
Ambient Temperature	During operation: 0°C to +45°C, During storage: -10°C to +60°C
Relative Humidity	90% max. (non-condensing)
Altitude	2000 m (with temperature derating) Derating condition of over 1000 m: max. ambient temperature decreases 1% per 100 m.
Power Supply	Japan: three-phase 200 VAC to 240 VAC (+10% to -15%), 50/60 Hz (±2%) Asia and Europe: three-phase 380 VAC to 440 VAC (+10% to -15%), 50/60 Hz (±2%) (neutral grounding) North America: three-phase 380 VAC to 480 VAC (+10% to -15%), 50/60 Hz (±2%) (neutral grounding)
Grounding	Grounding resistance: 100 Ω or less for 200-V class, 10 Ω or less for 400-V class
Digital I/Os	Specialized signals: 19 inputs and 6 outputs General signals: 40 inputs and 40 outputs (32 transistor outputs, 8 relay outputs)
Positioning System	Serial communications (absolute encoder)
Programming Capacity	JOB: 200,000 steps, 10,000 instructions CIO ladder: 20,000 steps max.
Expansion Slots	PCI express: 2 slots
LAN (Connection to Host)	2 (10BASE-T/100BASE-TX)
Interface	RS-232C: 1ch
Drive Units	SERVOPACK for AC servomotors

Programming Pendant Specifications

Items	Specifications
Dimensions	152 (W)×49.5 (D)×300 (H) mm
Approx. Mass	0.730 kg
Material	Reinforced plastics
Operation Device	Select keys, axis keys, numerical/application keys, mode selector switch with keys (mode: teach, play, and remote), emergency stop button, enable switch, compact flash card interface device (compact flash is optional.), USB port (USB 2.0, 1 port)
Display	5.7-inch TFT color LCD, touch panel VGA 640 × 480 pixels (alphanumeric characters, Chinese characters, Japanese letters, and others)
IEC Protection Class	IP54
Cable Length	Standard: 8 m, max.: 36 m (with optional extension cable)

YASKAWA ELECTRIC CORPORATION

2-1 Kurosakishiroishi, Yahatanishi-ku, Kitakyushu, 806-0004, Japan
Phone: +81-93-645-7703 Fax: +81-93-645-7802

YASKAWA AMERICA, INC. (MOTOMAN ROBOTICS DIVISION)

100 Automation Way, Miamisburg, OH 45342, U.S.A.
Phone: +1-937-847-6200 Fax: +1-937-847-6277

YASKAWA EUROPE GmbH (ROBOTICS DIVISION)

Yaskawastrasse 1, 85391, Allershausen, Germany
Phone: +49-8166-90-0 Fax: +49-8166-90-103

YASKAWA NORDIC AB

Verkstadsгатan 2, Box 504, SE-385 25 Torsås, Sweden
Phone: +46-480-417-800 Fax: +46-486-414-10

YASKAWA ELECTRIC (CHINA) CO., LTD.

22F, One Corporate Avenue, No.222 Hubin Road, Huangpu District, Shanghai 200021, China
Phone: +86-21-5385-2200 Fax: +86-21-5385-3299

YASKAWA SHOUANG ROBOT CO., LTD.

No.2 Building, No.6 Rongchang East Street, Beijing E&T Development Area, Beijing 100176, China
Phone: +86-10-6788-2858 Fax: +86-10-6788-2878

YASKAWA ELECTRIC KOREA CORPORATION

18F, KITB Bldg, 66 Yeoul-daero, Yeongdeungpo-gu, Seoul, 07325, Republic of Korea
Phone: +82-2-784-7844 Fax: +82-2-784-8495

YASKAWA ELECTRIC TAIWAN CORPORATION

12F, No.207, Sec. 3, Beishin Rd., Shindian District, New Taipei City 23143, Taiwan
Phone: +886-2-8913-1333 Fax: +886-2-8913-1513

YASKAWA ASIA PACIFIC PTE. LTD.

30A Kallang Place, #06-01, 339213, Singapore
Phone: +65-6282-3003 Fax: +65-6289-3003

YASKAWA ELECTRIC (THAILAND) CO., LTD.

59, 1st-5th Floor, Flourish Building, Soi Ratchadapisek 18, Ratchadapisek Road, Huaykwang, Bangkok 10310, Thailand
Phone: +66-2-017-0099 Fax: +66-2-017-0199

PT. YASKAWA ELECTRIC INDONESIA

Secure Building-Gedung B Lantai Dasar & Lantai 1 Jl. Raya Protokol Halim Perdanakusuma, Jakarta 13610, Indonesia
Phone: +62-21-2982-6470 Fax: +62-21-2982-6471

YASKAWA INDIA PRIVATE LIMITED (ROBOTICS DIVISION)

No.136, Sector-8, Industrial Estate, IMT Manesar, Gurugram, Haryana 122050, India
Phone: +91-124-475-8500 Fax: +91-124-475-8542

YASKAWA

YASKAWA ELECTRIC CORPORATION

In the event that the end user of this product is to be the military and said product is to be employed in any weapons systems or the manufacture thereof, the export will fall under the relevant regulations as stipulated in the Foreign Exchange and Foreign Trade Regulations. Therefore, be sure to follow all procedures and submit all relevant documentation according to any and all rules, regulations and laws that may apply. Specifications are subject to change without notice for ongoing product modifications and improvements.

© 2021 YASKAWA ELECTRIC CORPORATION

LITERATURE NO. CHEP C941111 10B <1>-0

Published in Japan September 2022
22-08-48