

2D Laser Scanners

LSE2 Series

INSTRUCTION MANUAL

TCD220024AB

Autonics

Thank you for choosing our Autonics product.

Read and understand the instruction manual and manual thoroughly before using the product.

For your safety, read and follow the below safety considerations before using.

For your safety, read and follow the considerations written in the instruction manual, other manuals and Autonics website.

Keep this instruction manual in a place where you can find easily.

The specifications, dimensions, etc. are subject to change without notice for product improvement. Some models may be discontinued without notice.

Follow Autonics website for the latest information.

Safety Considerations

- Observe all 'Safety Considerations' for safe and proper operation to avoid hazards.
- ⚠ symbol indicates caution due to special circumstances in which hazards may occur.

⚠ Warning Failure to follow instructions may result in serious injury or death.

- Fail-safe device must be installed when using the unit with machinery that may cause serious injury or substantial economic loss. (e.g. nuclear power control, medical equipment, ships, vehicles, railways, aircraft, combustion apparatus, safety equipment, crime / disaster prevention devices, etc.)**
Failure to follow this instruction may result in economic loss, personal injury or fire.
- Do not use the unit in the place where flammable / explosive / corrosive gas, high humidity, direct sunlight, radiant heat, vibration, impact, or salinity may be present.**
Failure to follow this instruction may result in fire or explosion.
- This product is not safety sensor and does not observe any domestic nor international safety standard.**
Do not use this product with the purpose of injury prevention or life protection, as well as in the place where economic loss may be expected.
- Do not connect, repair, or inspect the unit while connected to a power source.**
Failure to follow this instruction may result in fire.
- Check connections and connect cables.**
Failure to follow this instruction may result in fire.
- Do not disassemble or modify the unit.**
Failure to follow this instruction may result in fire.

⚠ Caution Failure to follow instructions may result in injury or product damage.

- Do not stare at the laser emitter.**
Failure to follow this instruction may result in eye damage.
- Use the unit within the rated specifications.**
Failure to follow this instruction may result in fire or product damage.
- Use dry cloth to clean the unit. Do not use water or organic solvent when cleaning the unit.**
Failure to follow this instruction may result in fire.
- Do not apply high pressure to the laser scanner to clean it.**

Cautions during Use

- Follow instructions in 'Cautions during Use'. Otherwise, it may cause unexpected accidents.
- Power supply should be insulated and limited voltage / current or Class 2, SELV power supply device.
- After supplying power, the sensor performs self-check for about 10 sec. When self-checking, error occurrence, and teaching, the laser scanner outputs the same as it sensed obstacle.
- Do not arbitrarily extend the length of the laser scanner power I/O cable and communication cable. It may cause malfunction. Mutual optical interference between laser scanners and photoelectric sensors may result in malfunction.
- Mutual optical interference between laser scanners may result in malfunction.
- Do not touch or contaminate the laser scanner front cover. It may cause malfunction.
- Objects cannot be scanned when covering the front cover of the laser scanner.
- When the laser scanner is moved to another position, use it after re-teaching.
- Do not drop the unit. It may cause malfunction.
- Installing the laser scanner in the place where smoke, fog, dust, or corrosion is heavy may result in malfunction.
- When installing the laser scanner outdoors, take protective measures. Otherwise, it may result in product damage.
- Keep away from high voltage lines or power lines to prevent inductive noise. In case of installing power line and input signal line closely, use line filter or varistor at power line and shield wire at input signal line.
- Do not use the laser scanner near the equipment which generates strong magnetic force or high frequency noise.
- Cover with shields, hoods, or etc. to prevent direct incidence of strong light (direct rays of sunlight, incandescent) into the laser scanner beam spread angle.
- Fix the laser scanner in position with the fixing screw. Vibration may result in malfunction.

- When IP address of the laser scanner and wireless router is same, the communication does not connected. Set the wireless network (Wifi) to "Disable" in the network settings of the Windows operating system.
- This unit may be used in the following environments.
 - Indoors / Outdoors (in the environment condition rated in 'Specifications')
 - Altitude max. 2,000 m
 - Pollution degree 2
 - Installation category II

Product Components

- Product
- Instruction manual

Software

Download the installation file and the manuals from the Autonics website.

Supported devices are different for each software version.

■ atLiDAR (PC, V2.1 or later)

atLiDAR is the management program for laser scanner parameter settings, status information and monitoring data, etc.

This program communicates with the laser scanner via Ethernet communication.

■ atLiDAR (mobile)

atLiDAR is Android only mobile application that can manage monitoring data such as laser scanner parameter settings and status information.

Connect the laser scanner with atLiDAR by connecting the USB3.0-C to Ethernet adapter.

Manual

For proper use of the product, refer to the manuals and be sure to follow the safety considerations in the manuals.

Download the manuals from the Autonics website.

Sold Separately

- Main bracket: BK-LSE2
- Sub bracket: BK-LSE2-SUB

Network Setting

- Configure the network settings of LiDAR sensor via atLiDAR (PC).
- For initial IP address, refer to the table as below.

IP address	192.168.0.1
Subnet mask	255.255.255.0
Gateway	192.168.0.2

Installation Order

For details of atLiDAR (PC / mobile) settings, refer to the software manual.

- Install the laser scanner.**
Secure the device to the installation location through three M4 × 0.7 DP 6 mm holes.
- Install the laser scanner program to PC.**
Download the software provided by Autonics website.
- Connect the laser scanner and the PC, and set the network.**
Refer to the Network Setting.
- Laser scanner function setting**
Use atLiDAR (PC / mobile), set each function to adequate the installation environment of the laser scanner and the obstacles to be detected.

Mounting Bracket

- Connect the sensor and the main bracket using 3 M4 × L8 bolts.
 - Adjust the beam position using 3 M5 bolts that are fastened to the main bracket.
 - After adjusting the beam position, use 2 M4 × L10 bolts to fix the main bracket so that it does not shake.
- For 45° / -45° / 90° installation, additional sub bracket combinations are available.
 - For details, refer to the product manual.

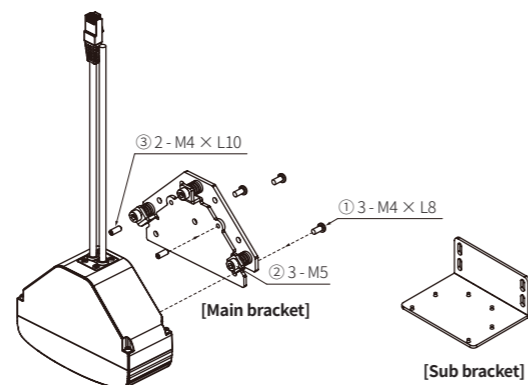

Cautions for Installation

- To prevent mutual interference when installing multiple devices, refer to the below.

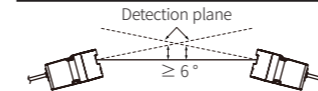

Tilt the devices and install them so that the scanning planes are tilted to each other.

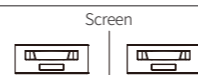

Install a screen to block direct laser beam interference between the devices.

Connections

■ Power I / O cable

Color	Pin	Signal	Function
Brown	1	+V	+V
Blue	2	GND	GND
Yellow	3	OUT1_A	Obstacle detection output
Green	4	OUT1_B	Obstacle detection output
Red	5	OUT2_A	Error status output
Gray	6	OUT2_B	Error status output
White	7	IN_A	Output test mode
Black	8	IN_B	Output test mode

■ Ethernet cable

Color	Pin	Signal
White	1	TX+
Black	2	TX-
Red	3	RX+
-	4	-
-	5	-
Green	6	RX-
-	7	-
-	8	-

- The input / output signals can operate in both direction regardless of the polarity.
- When the output test mode is not used, do not wire both end of input terminal, or supply power under 3 VDC=.

Control Input / Output Status

Output Input	OUT1 (obstacle detection output)	OUT2 (error status output)
ON	-	ON -
OFF	ON <ul style="list-style-type: none"> Obstacle detection Teaching Error status Scanning ready (Approx. 10 sec after power on) 	ON <ul style="list-style-type: none"> Error status Scanning ready (Approx. 10 sec after power on)
	OFF	OFF
		OFF

Circuit

■ Photocoupler input

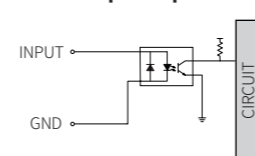

■ PhotoMOS relay output

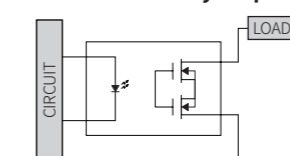

Dimensions

- Unit: mm, For the detailed drawings, follow the Autonics website.

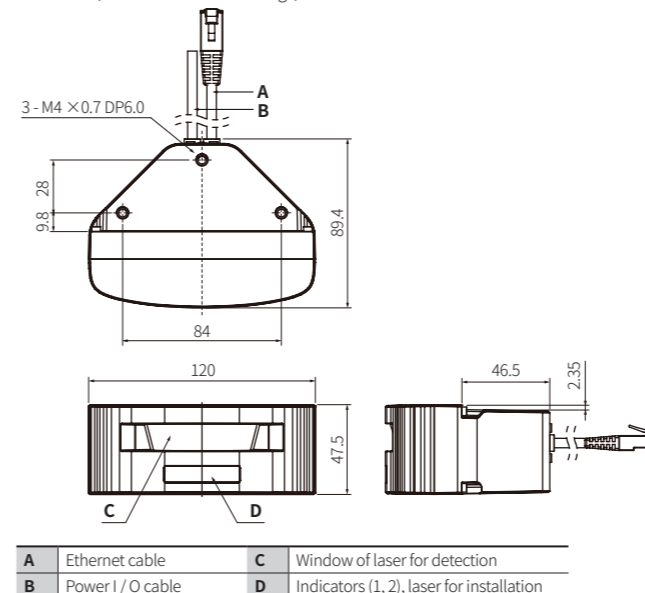

Specifications

Model	LSE2-A5R2-ET
Laser for detection emitting property	Infrared laser: 1
Laser class	CLASS 1
Wave length band	905 nm
Max. pulse output power	27 W
Laser for installation emitting property	Visible light laser: 2
Laser class	CLASS 3R
Wave length band	650nm
Max. CW ⁽⁰¹⁾ output power	4 mW
Min. object size⁽⁰²⁾	OFF, 5, 8, 10, 15, 20, 25, 30, 35, 40 cm
Scanning frequency	25 Hz
Response time	≤ 50 ms + monitoring time
Monitoring zone⁽⁰³⁾	≤ 5.6 × 5.6 m
Angular resolution	0.25°
Aperture angle	90°
Object reflectivity⁽⁰⁴⁾	≥ 2 %
Approval	CE
Korean Railway Standards	KRS SG 0068
Unit weight (package)	≈ 0.8 kg (≈ 1 kg)

01) Continuous wave

02) It is based on a white reflector.

Even objects smaller than the set min. object size can be detected depending on the environment.

03) At detection distance: 4 m, object reflectivity: 5%, fog filter level: 0

04) At detection distance: 1.5 m, fog filter level: 0, object size = W 700 × H 300 × L 200 mm

Power supply	24 VDC= ± 15 %
Power consumption	< 10 W
Input	Photocoupler input: 1 H ⁽⁰¹⁾ : ≥ 8 - 30 VDC=, L: ≤ 3 VDC=
Output	PhotoMOS relay output: 2 Resistive load: 30 VDC= / 24 VAC~, ≤ 80 mA
Vibration	2 G
Shock	30 G / 18 ms
Ambient illuminance	Sunlight: ≤ 100,000 lx
Ambient temperature	-30 to 60 °C, storage: -30 ~ 70 °C (no freezing or condensation)
Ambient humidity	0 to 95 %RH, storage: 0 to 95 %RH (no freezing or condensation)
Protection structure	IP67 (IEC standard)
Cable spec.	Power I / O cable: Ø 5 mm, 8-wire, 5 m Ethernet cable: Ø 5 mm, 4-wire, 3 m, shield cable, RJ45 connector
Wire spec.	AWG26 (0.16 mm, 7-core), insulator outer diameter: Ø 1 mm
Material	Case: AL, Window: PC

01) Operates as output test mode and outputs obstacle detection output and error status output.

Communication Interface

■ Ethernet

Communication protocol	TCP/IP
Communication speed	10BASE-TX
Baud rate	10Mbps

Indicators

The operation of indicator not stated in the description is unrelated with the status.

■ Indicator by situation

Status		No.1 (green)	No.2 (red)
Power	ON	ON → OFF (once)	ON → OFF (once)
	Normal operation	ON	-
Comm.	Connection	Flashing	-
	Parameter download	ON → OFF (once)	ON → OFF (once)
Obstacle detection	ON	ON	
Output test mode	Flashing	Flashing	
Teaching	Preparation	Flashing (for 5 sec)	-
	Progress	-	Flashing (for 60 sec)

■ Error indicator

Status	No.1 (yellow)	No.2
Anti-masking	ON	ON (red)
Background	ON	Flashing (red)
Comm. error	ON	-
Voltage error	Flashing	Flashing (yellow)
Temperature error	Flashing	-
product problem ⁽⁰¹⁾	Flashing	ON (yellow)

01) Please contact us.