



SPECIFICATION

DISPLAY

- 1 Row of 6 Digits to show electrical parameters
- 7 Segment LED Display 71*24mm
- Digital integrated with parameter units

INDICATION

- EXP** - CT Reverse Detection
- k** - Kilo
- M** - Mega
- ↔*** - Communication in progress
- DG*** - DG sensing

WIRING INPUT

- 3Ø - 4 wire, 3Ø - 3 wire, and 1Ø - 2 wire system

RATED INPUT VOLTAGE

- 11 to 277 VAC (L-N): 19 to 480 VAC (L-L)CATII
- 11 to 300 VAC (L-N): 19 to 519 VAC (L-L)CATIII
- Installation Category III

FREQUENCY RANGE

- 45-65 Hz

RATED INPUT CURRENT

- Nominal 5A AC (Min-50mA, Max-6A)

BURDEN

- 0.5 VA@5A per phase

CT PRIMARY

- 1A / 5A to 10,000A (Programmable for any value)
- Note** : 1A to 10,000A if CT secondary is 1 else CT primary is 5A to 10,000A

CT SECONDARY

- 1A or 5A (programmable)

PT PRIMARY

- 100V to 500kV (Programmable for any value)

PT SECONDARY

- 100 to 500V (Programmable for any value)

POWER CONSUMPTION

- Less than 8VA

DISPLAY UPDATE TIME *

- 1 sec for all parameters

DISPLAY SCROLLING *

- Automatic or Manual (Programmable)

ENVIRONMENTAL CONDITIONS

- Indoor use
- Altitude of up to 2000 meters
- Pollution degree II

Temperature : Operating : -10°C to 55°C

Storage : -20°C to 75°C

Humidity : Up to 85% non-condensing phase

PROTECTION CLASS : II

INSTALLATION CATAGORY : III

MOUNTING : Panel mounting

WEIGHT : 210gms

OUTPUT (Only for EM306)

Pulse output : Voltage range external 24V DC max
Current capacity : 100mA

Pulse width : 100ms ±5ms

DIGITAL INPUT *

Voltage(L-N): 85 to 276V AC

(Note: * = Only for EM306-C-D)

RESOLUTION

PT Ratio x CT Ratio	kWh	Pulse output kWh/pulse
<15	0.01K	0.01
<150	0.1K	0.1
<1500	1K	1
<15000	0.01M	10
<150000	0.1M	100
≥150000	1M	1000

NOTE

- Power resolution is automatically adjusted.
- For power factor, resolution is 0.001.

ORDER CODE INFORMATION

Product	Supply Voltage	Certification	
		CE	UL LISTED
EM306	85 to 276V AC, 50/60Hz	—	—
EM306-C-D	85 to 276V AC, 50/60Hz	—	—

SERIAL COMMUNICATION (Only for EM306-C-D)

Interface standard and protocol	RS485 and MODBUS RTU
Communication address	1 to 255
Transmission mode	Half duplex
Data types	Float, Integer and Hex
Transmission distance	500m maximum
Transmission Speed	300, 600, 1200, 2400, 4800, 9600, 19200 (in bps)
Parity	None, Odd, Even
Stop bits	1 or 2
Response Time	100ms (Max & Independent at baud rate)

ACCURACY

Measurement	Accuracy
Active Power*	1%
Apparent power*	1%
Reactive Power*	2%
Power factor*	±0.01 Digit
Active energy	Class 1
Reactive energy*	Class 2

(Note: * = Only for EM306-C-D)

SAFETY PRECAUTIONS

All safety related codifications, symbols and instructions that appear in this operating manual or on the equipment must be strictly followed to ensure the safety of the operating personnel as well as the instrument.

If the equipment is not used in a manner specified by the manufacturer it might impair the protection provided by the equipment.

- Do not use the equipment if there is any mechanical damage.
- Ensure that the equipment is supplied with correct voltage.

CAUTION :

- Read complete instructions prior to installation and operation of the unit.
- Risk of electric shock.
- The equipment in its installed state must not come in close proximity to any heating sources, oils, steam, caustic vapors or other unwanted process by products.

WARNING :

- To prevent the risk of electric shock, power supply to the equipment must be kept OFF while doing the wiring arrangement.
- Wiring shall be done strictly according to the terminal layout. Confirm that all connections are correct.
- Use lugged terminals.
- To reduce electromagnetic interference use of wires with adequate ratings and twists of the same in equal size shall be made with shortest connections.
- Layout of connecting cables shall be away from any internal EMI source.
- Cable used for connection to power source, must have a cross section of 0.5mm² to 2.5mm² (20 to 14AWG ; 75°C (minimum)). These wires shall have current carrying capacity of 6A.
- Copper cable should be used. (Stranded or Single core cable).
- Before attempting work on device, ensure absence of voltages using appropriate voltage detection device.
- Recommended CT : Measuring type.

INSTALLATION GUIDELINES

CAUTION :

- This equipment, being built-in-type, normally becomes a part of main control panel and in such case the terminals do not remain accessible to the end user after installation and internal wiring.
- Conductors must not come in contact with the internal circuitry of the equipment or else it may lead to a safety hazard that may in turn endanger life or cause electrical shock to the operator.
- Circuit breaker or mains switch must be installed between power source and supply terminals to facilitate power 'ON' or 'OFF' function. However this switch or breaker must be installed in a convenient position normally accessible to the operator.
- Before disconnecting the secondary of the external current transformer from the equipment, make sure that the current transformer is short circuited to avoid risk of electrical shock and injury.
- The equipment shall not be installed in environmental conditions other than those mentioned in this manual.
- The equipment does not have a built-in-type fuse. Installation of external fuse of rating 275V AC / 0.5Amp for electrical circuitry / battery is highly recommended.

MECHANICAL INSTALLATION

For installing the meter

- Prepare the panel cutout with proper dimensions as shown below.
- Push the meter into the panel cutout. Secure the meter in its place by fitting the clamp on the rear side. Fit clamps on both sides in diagonally opposite location for optimum fitting.
- For proper sealing, tighten the screws evenly with required torque.

Terminal screw tightening torque:
0.68 N-m to 0.79 N-m (6.018 In-Lb to 6.992 In-Lb)
Screw clamp tightening torque : 0.1 N-m (0.885 Lb-inch)

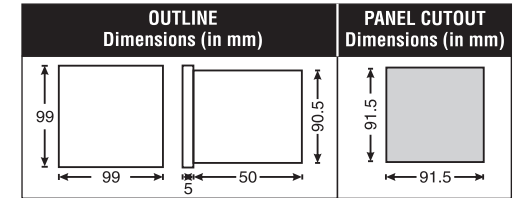

MAINTENANCE

- The equipment should be cleaned regularly to avoid blockage of ventilating parts.
- Clean the equipment with a clean dry or damp cloth. Do not use any cleaning agent other than water.

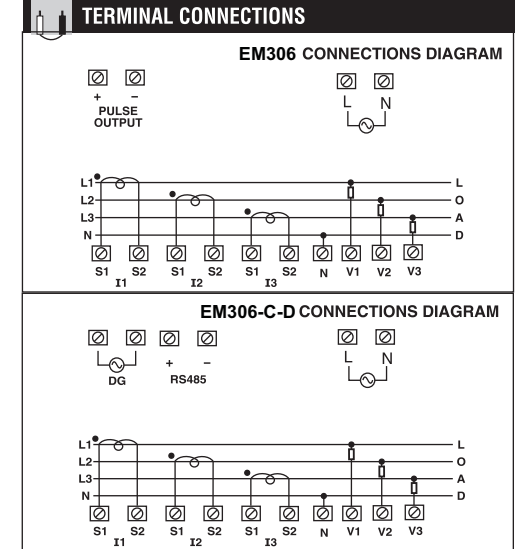

FRONT PANEL DESCRIPTION



ONLINE PAGE DESCRIPTION (Only for EM306)

Display will show only kWh page.

Press "↵"	Display roll-over count of kWh.	
-----------	---------------------------------	--

ONLINE PAGE DESCRIPTION (Only for EM306-C-D)

By default total kWh page will be displayed and after pressing any key, next page of last accessed page will be shown. If no key is pressed for 60 seconds in manual mode, display will go to default page i.e total kWh of mains, & if DG is on, display will go to total kWh of DG.

For 3P4W		
KEY PRESS	ONLINE PAGE DESCRIPTION	DISPLAY
Press "PF"	The first screen : Displays unit of R phase power factor for a second, then display value.	PF 1
	The second screen : Displays unit of Y phase power factor for a second, then display value.	PF 2
	The third screen : Displays unit of B phase power factor for a second, then display value.	PF 3
	The fourth screen : Displays unit of average of all three phase power factor then display value.	PFAVG
NOTE: 1.For 3Ø 3W system, only 4th screen will be visible. 2.For 1Ø 2W-R system, only 1st screen will be visible. 3.For 1Ø 2W-Y system, only 2nd screen will be visible. 4.For 1Ø 2W-B system, only 3rd screen will be visible.		

For 3P4W														
KEY PRESS	ONLINE PAGE DESCRIPTION	DISPLAY												
Press "P"	The first screen : Displays unit of active power of R phase for a second, then displays value.	Y 1												
	The second screen : Displays unit of active power of Y phase for a second, then display value.	Y 2												
	The third screen : Displays unit of active power of B phase for a second, then display value.	Y 3												
	The fourth screen : Displays unit of total active power for a second, then display value.	Y 4												
	The fifth screen : Displays unit of active energy of R phase for a second, then display value.	YH 1												
	The sixth screen : Displays unit of active energy of Y phase for a second, then display value.	YH 2												
	The seventh screen : Displays unit of active energy of B phase for a second, then display value.	YH 3												
	The eighth screen : Displays unit of total active energy of MAINS source for a second, then display value.	YH 4												
	The ninth screen : Displays unit of total active energy of DG source for a second, then display value. DG symbol ON	YH 4												
	The tenth screen : Displays unit of total active energy of MAINS + DG source for a second, then display value. DG symbol ON.	YH 4												
NOTE: <table border="1"> <thead> <tr> <th>Network</th> <th>Visible screen</th> </tr> </thead> <tbody> <tr> <td>3Ø 3W</td> <td>4th, 8th, 9th & 10th</td> </tr> <tr> <td>1Ø 2W-R</td> <td>1st, 8th, 9th & 10th</td> </tr> <tr> <td>1Ø 2W-Y</td> <td>2nd, 8th, 9th & 10th</td> </tr> <tr> <td>1Ø 2W-B</td> <td>3rd, 8th, 9th & 10th</td> </tr> <tr> <td>DG</td> <td>1st, 2nd, 3rd, 4th, 8th, 9th & 10th</td> </tr> </tbody> </table>			Network	Visible screen	3Ø 3W	4th, 8th, 9th & 10th	1Ø 2W-R	1st, 8th, 9th & 10th	1Ø 2W-Y	2nd, 8th, 9th & 10th	1Ø 2W-B	3rd, 8th, 9th & 10th	DG	1st, 2nd, 3rd, 4th, 8th, 9th & 10th
Network	Visible screen													
3Ø 3W	4th, 8th, 9th & 10th													
1Ø 2W-R	1st, 8th, 9th & 10th													
1Ø 2W-Y	2nd, 8th, 9th & 10th													
1Ø 2W-B	3rd, 8th, 9th & 10th													
DG	1st, 2nd, 3rd, 4th, 8th, 9th & 10th													

Press "Q"	The first screen : Displays unit of reactive power of R phase for a second, then display value.	YAR 1
	The second screen : Displays unit of reactive power of Y phase for a second, then display value.	YAR 2
	The third screen : Displays unit of reactive power of B phase for a second, then display value.	YAR 3
	The fourth screen : Displays unit of total reactive power for a second, then display value.	YAR 4
	The fifth screen : Displays unit of reactive energy of R phase for a second, then display value.	YARH 1
	The sixth screen : Displays unit of reactive energy of Y phase for a second, then display value.	YARH 2

Press "Q"	The seventh screen : Displays unit of reactive energy of B phase for a second, then display value.	YARH 3												
	The eighth screen : Displays unit of total reactive energy of MAINS source for a second, then display value.	YARH 4												
	The ninth screen : Displays unit of total reactive energy of DG source for a second, then display value. DG symbol ON	YARH 4												
	The tenth screen : Displays unit of total reactive energy of MAINS + DG source for a second, then display value. DG symbol ON.	YARH 4												
NOTE: <table border="1"> <thead> <tr> <th>Network</th> <th>Visible screen</th> </tr> </thead> <tbody> <tr> <td>3Ø 3W</td> <td>4th, 8th, 9th & 10th</td> </tr> <tr> <td>1Ø 2W-R</td> <td>1st, 8th, 9th & 10th</td> </tr> <tr> <td>1Ø 2W-Y</td> <td>2nd, 8th, 9th & 10th</td> </tr> <tr> <td>1Ø 2W-B</td> <td>3rd, 8th, 9th & 10th</td> </tr> <tr> <td>DG</td> <td>1st, 2nd, 3rd, 4th, 8th, 9th & 10th</td> </tr> </tbody> </table>			Network	Visible screen	3Ø 3W	4th, 8th, 9th & 10th	1Ø 2W-R	1st, 8th, 9th & 10th	1Ø 2W-Y	2nd, 8th, 9th & 10th	1Ø 2W-B	3rd, 8th, 9th & 10th	DG	1st, 2nd, 3rd, 4th, 8th, 9th & 10th
Network	Visible screen													
3Ø 3W	4th, 8th, 9th & 10th													
1Ø 2W-R	1st, 8th, 9th & 10th													
1Ø 2W-Y	2nd, 8th, 9th & 10th													
1Ø 2W-B	3rd, 8th, 9th & 10th													
DG	1st, 2nd, 3rd, 4th, 8th, 9th & 10th													

For 3P4W														
KEY PRESS	ONLINE PAGE DESCRIPTION	DISPLAY												
Press "S"	The first screen : Displays unit of Apparent power of R phase for a second, then display value.	YAR 1												
	The second screen : Displays unit of Apparent power of Y phase for a second, then display value.	YAR 2												
	The third screen : Displays unit of Apparent power of B phase for a second, then display value.	YAR 3												
	The fourth screen : Displays unit of total Apparent power for a second, then display value.	YAR 4												
	The fifth screen : Displays unit of Apparent energy of R phase for a second, then display value.	YARH 1												
	The sixth screen : Displays unit of Apparent energy of Y phase for a second, then display value.	YARH 2												
	The seventh screen : Displays unit of Apparent energy of B phase for a second, then display value.	YARH 3												
	The eighth screen : Displays unit of total Apparent energy of MAINS source for a second, then display value.	YARH 4												
	The ninth screen : Displays unit of total Apparent energy of DG source for a second, then display value. DG symbol ON	YARH 4												
	The tenth screen : Displays unit of total Apparent energy of MAINS + DG source for a second, then display value. DG symbol ON.	YARH 4												
NOTE: <table border="1"> <thead> <tr> <th>Network</th> <th>Visible screen</th> </tr> </thead> <tbody> <tr> <td>3Ø 3W</td> <td>4th, 8th, 9th & 10th</td> </tr> <tr> <td>1Ø 2W-R</td> <td>1st, 8th, 9th & 10th</td> </tr> <tr> <td>1Ø 2W-Y</td> <td>2nd, 8th, 9th & 10th</td> </tr> <tr> <td>1Ø 2W-B</td> <td>3rd, 8th, 9th & 10th</td> </tr> <tr> <td>DG</td> <td>1st, 2nd, 3rd, 4th, 8th, 9th & 10th</td> </tr> </tbody> </table>			Network	Visible screen	3Ø 3W	4th, 8th, 9th & 10th	1Ø 2W-R	1st, 8th, 9th & 10th	1Ø 2W-Y	2nd, 8th, 9th & 10th	1Ø 2W-B	3rd, 8th, 9th & 10th	DG	1st, 2nd, 3rd, 4th, 8th, 9th & 10th
Network	Visible screen													
3Ø 3W	4th, 8th, 9th & 10th													
1Ø 2W-R	1st, 8th, 9th & 10th													
1Ø 2W-Y	2nd, 8th, 9th & 10th													
1Ø 2W-B	3rd, 8th, 9th & 10th													
DG	1st, 2nd, 3rd, 4th, 8th, 9th & 10th													

Note: Energy value shown on 2 different pages account for increased maximum value. First page displays the first 3 digits of energy value. Second page displays the remaining digits of energy value. Both pages automatically switch after 2 seconds.

AUTOMATIC / MANUAL MODE DESCRIPTION

Press key for 5 seconds to toggle between Automatic and Manual mode.
Note : By default unit operates in automatic mode. In automatic mode online pages scroll automatically at the rate of 5 seconds per page. In automatic mode when any key is pressed, unit temporarily switches to manual mode and the appropriate page is displayed, also if any key is not pressed for 5 sec, unit resumes automatic mode.
Note: Only For EM306-C-D

USER GUIDE	
LED INDICATIONS	
<ul style="list-style-type: none"> INT : The INT LED provides optical output for calibration verification as well as visual indication of energy integration. The pulse rate is 1000 Pulses/kWh. EXP: EXP LED gives the indication of reversal of one or more CT connections or presence of negative power in any or all phases. In such cases meter may not indicate the correct energy consumption. The CT should be connected to the meter with correct polarities. 	
SERIAL NUMBER DESCRIPTION	
Press key for 10 sec. to display serial number.	

CONFIGURATION	
Note : Setting should be done by professional after going through this user manual and having understood the application situation.	
For the configuration setting mode:	
<ul style="list-style-type: none"> Use + key for 3 sec to enter and exit from configuration menu. Use key to shift the cursor for next digit and to edit. Use key to increment the configuration value. Use key to decrement the configuration. Use key for save parameter value & go to the next page 	

Config. page	Function	Range or Selection	Factory Setting	Display
	Password	0000 to 9998	1000	PASWD
1	Change Password	No / Yes	No	CHG PWD
1.1	New Password	0000 to 9998		NEW PWD
2	Network Selection	3P4W, 3P3W, 1P2W-R, 1P2W-Y and 1P2W-B	3P4W	NY SEL
3	CT Secondary	1A or 5A	5	CT SEC
4	CT Primary	1A, 5A to 10,000A	5	CT PRI
5	PT Secondary	100V to 500V	350	PT SEC
6	PT primary	100V to 500kV	350	PT PRI
7	Slave Id *	1 to 255	1	SLVEID
8	Baud Rate*	300, 600, 1200, 2400, 4800, 9600 and 19200 (bps)	9600	BD RATE
9	Parity*	None, Odd, Even	None	PARITY
10	Stop Bit*	1 or 2	1	STPBIT
11	Factory default	Yes / No	No	DEFAULT
12	Reset energy	Yes / No	No	RESET EN
13	Password	0001 to 9999	1001	PASWD
13.1	Source Selection *	Source1 (Mains) / Source2 (Generator)	Source 1 (Mains)	SOURCE
13.11	Reset active energy	Yes / No	No	YH
13.12	Reset reactive energy*	Yes / No	No	YARH
13.13	Reset apparent energy*	Yes / No	No	YARH

NOTE : For resetting energy parameters user will be prompted the password. If correct password is entered, the user will be able to reset all energy parameters. This password will be a value which will be greater than the configuration password by 1.
 (* = Only for EM306-C-D)

MODBUS REGISTER ADDRESSES LIST

Readable Parameters : [Length (Register) : 2 ;
Data Structure : Float]

Address	Hex Address	Parameter
30024	0x18	kW1
30026	0x1A	kW2
30028	0x1C	kW3
30030	0x1E	kVA1
30032	0x20	kVA2
30034	0x22	kVA3
30036	0x24	kVAr1
30038	0x26	kVAr2
30040	0x28	kVAr3
30042	0x2A	Total kW
30044	0x2C	Total kVA
30046	0x2E	Total kVAr
30048	0x30	PF1
30050	0x32	PF2
30052	0x34	PF3
30054	0x36	Average PF
30058	0x3A	Total kWh
30060	0x3C	Total kVAh
30062	0x3E	Total kVArh
30074	0x4A	Total kWh DG
30076	0x4C	Total kVAh DG
30078	0x4E	Total kVArh DG
30122	0x7A	Total kWh Mains+DG
30124	0x7C	Total kVAh Mains+DG
30126	0x7E	Total kVArh Mains+DG
30128	0x80	DG Sensing
30200	0x3A	Total kWh*
30202	0x3C	Total kVAh*
30204	0x3E	Total kVArh*
30264	0x4A	Total kWh DG*
30266	0x4C	Total kVAh DG*
30268	0x4E	Total kVArh DG*
30258	0x7A	Total kWh Mains+DG*
30262	0x7C	Total kVAh Mains+DG*
30260	0x7E	Total kVArh Mains+DG*
30684	0x2AC	Serial no. (Data Structure : Hex)

Note: * address are for first 3 digit of energy values.
For the energy value greater than 0000.00, add the value of both address of same energy.

Example: For Total kWh,
Value at 30058 is 7654.32 and value at 30200 is 98.
Actual value of Total kWh is 987654.32.

Value at 30200 98	Value at 30058 7654.32
987654.32 Actual value on display	

APPLICATION OF PULSE OUTPUT

● PROCESS INTEGRATION

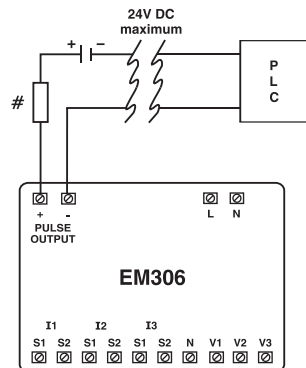

Pulse output from meter can be interfaced into a process through a PLC for on line control of energy content in the process.

If the PLC has a self excited digital input, External DC supply is not needed
The kWh pulse is also used to device average kWh information at the PLC.

Note: Only for Em306

APPLICATION OF PULSE OUTPUT

● ENERGY CONTROLLER

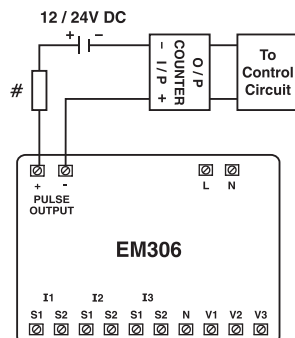

Pulse output from meter can be used as alarm generator or total energy controller by interfacing it with Pre settable counter and control circuits (Contactors, Relay, Trip Circuit).

The counter is loaded with the maximum energy consumption. When count reaches setpoint it provides output to control circuit to take appropriate action.

All fuse types : 0.5A class CC UL type
0.5A fast acting 600V

Note: Only for EM306

NETWORK SELECTION AND WIRING INPUT

Network selection in configuration mode	Wiring
3P4W	3P4W, 2P3W
3P3W	3P3W
1P2W (P1/P2/P3)	1P2W (P1/P2/P3)

Note : P1, P2 and P3 are Three Phase.

MODBUS REGISTER ADDRESSES LIST

Readable / writable parameters : [Data Structure : Integer]

Address	Hex Address	Parameter	Range		Length (Register)
40000	0x00	Password	Min value : 0	Max value : 9998	1
40001	0x01	N/W Selection	Value : 0	Meaning : 3P4W	1
			Value : 1	Meaning : 3P3W	1
			Value : 2	Meaning : 1P2W-R	1
			Value : 3	Meaning : 1P2W-Y	1
			Value : 4	Meaning : 1P2W-B	1
40002	0x02	CT Secondary	Min value : 1	Max value : 5	1
40003	0x03	CT primary (CT Secondary=5)	Min value : 5	Max value : 10000	1
		CT primary (CT Secondary=1)	Min value : 1	Max value : 10000	
40004	0x04	PT Secondary	Min value : 100	Max value : 500	1
40005	0x05	PT primary	Min value : 100	Max value : 500kV	2
40007	0x07	Slave id	Min value : 1	Max value : 255	1
40008	0x08	Baud rate	Value : 0x0000	Meaning : 300	1
			Value : 0x0001	Meaning : 600	
			Value : 0x0002	Meaning : 1200	
			Value : 0x0003	Meaning : 2400	
			Value : 0x0004	Meaning : 4800	
			Value : 0x0005	Meaning : 9600	
			Value : 0x0006	Meaning : 19200	
40009	0x09	Parity	Value : 0x0000	Meaning : None	1
			Value : 0x0001	Meaning : Odd	
			Value : 0x0002	Meaning : Even	
40010	0x0A	Stop bit	Value : 0x0000	Meaning : 1	1
			Value : 0x0001	Meaning : 2	
40012	0x0C	Factory Default	Value : 1	Meaning : Set to factory setting range	1
40013	0x0D	Reset Active Energy	Value : 1	Meaning : Reset Total Active Energy	1
40014	0x0F	Reset Apparent Energy	Value : 1	Meaning : Reset Total Apparent Energy	1
40015	0x10	Reset Reactive Energy	Value : 1	Meaning : Reset Total Reactive Energy	1
40042	0x2A	Reset Active Energy DG	Value : 1	Meaning : Reset Total Active Energy of DG	1
40043	0x2B	Reset Apparent Energy DG	Value : 1	Meaning : Reset Total Reactive Energy of DG	1
40044	0x2C	Reset Reactive Energy DG	Value : 1	Meaning : Reset Total Apparent Energy of DG	1

CONNECTION DIAGRAM FOR COMMUNICATION

CONNECTION DIAGRAM FOR COMMUNICATION

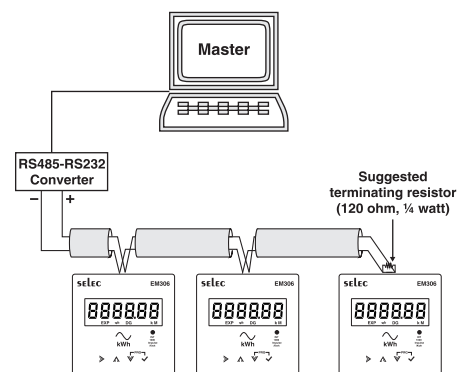

Contact sales for PC based monitoring software to communicate with the meters.

Note: Only for Em306-C-D

APPLICATION OF DIGITAL INPUT

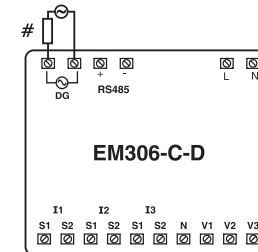

Note: Only for Em306-C-D

TYPICAL WIRING DIAGRAM

3 PHASE 4-WIRE (COMMONLY USED)

3 Ø - 4 WIRE, 3 CT'S

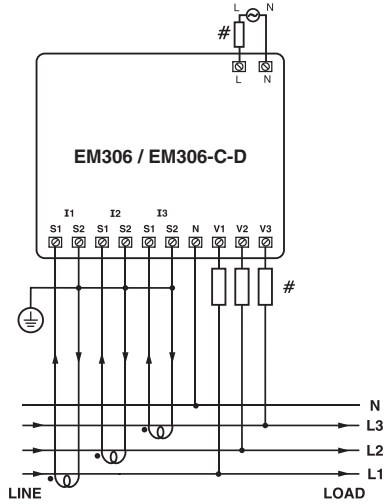

3 PHASE 3-WIRE

3 Ø - 3 WIRE, 2 CT'S

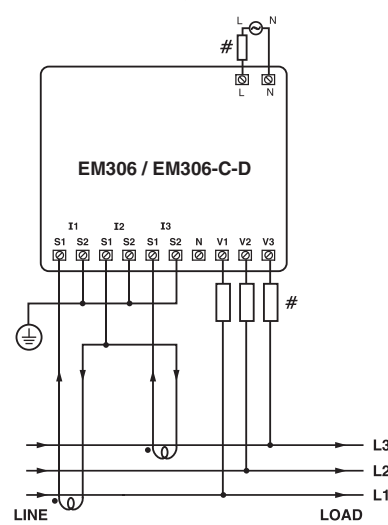

1 PHASE - 2 WIRE

1 Ø - 2 WIRE, 1 CT

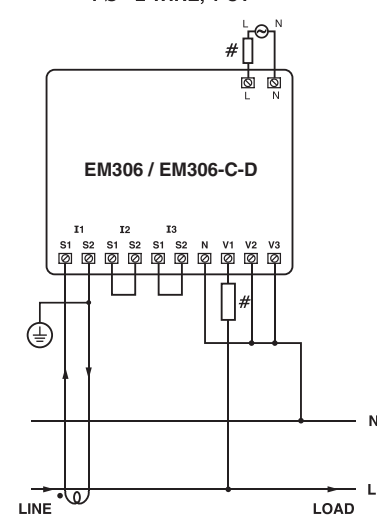

3 Ø - 4 WIRE, 3 CT'S and 3 PT'S

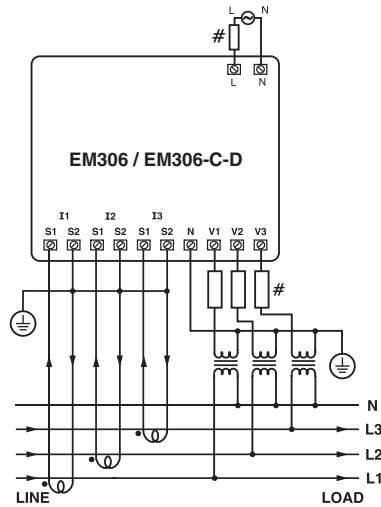

3 Ø - 3 WIRE, 2 CT'S and 2 PT'S

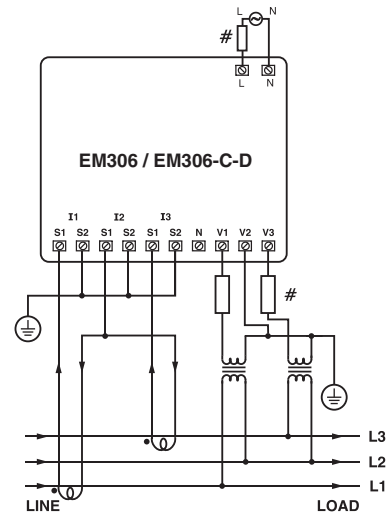

All fuse types : 0.5A class CC UL type
0.5A fast acting 600V

LUG DESCRIPTION

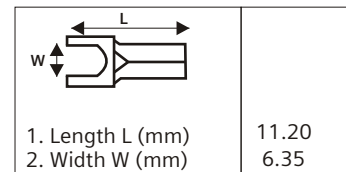

(NOTE : to be wired with LUG only)

Specifications are subject to change, since development is a continuous process.

Selec Controls Pvt. Ltd.

Factory Address : EL-27/1, Electronic Zone, TTC Industrial Area, MIDC, Mahape, Navi Mumbai - 400 710, INDIA.

Website : www.selec.com

For Sales & Support,

Tel. No. : +91-22-41 418 419/430

Mob No. : +9136977315. **Email :** sales@selec.com

For Service,

Tel. No. : +91-7498077172 / +91-7400069545

Email : service@selec.com