

# Series IP8

## Electro-Pneumatic Positioner/Smart Positioner (Lever type/Rotary type)



### Dustproof / Waterproof

Passed by external organization on JIS F8007 (conforms to IEC 60529) IP65

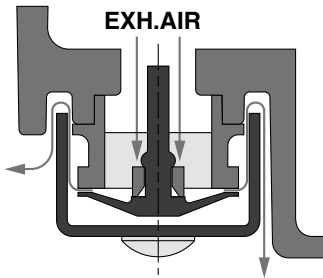

A centralized exhaust system employs the combination of the check valve and the labyrinth effect enhancing both dustproof and waterproof performance.

### Monitoring function

#### Electro-Pneumatic Positioner

- Opening current transmission analog (4 to 20 mA DC) continuous output

#### Smart Positioner

- Alarm point output function (2 points)
- Analog (4 to 20 mA DC) continuous output

### With external scale plate (Rotary type, Bottom mounting)



#### External scale plate

Improved visibility of opening indicator

### Explosion-proof construction

Electro-Pneumatic Positioner	TIIS explosion-proof construction (Exd II BT5)
	ATEX intrinsically safe explosion-proof construction (II 2G Ex ib II CT5/T6)
Smart Positioner	ATEX intrinsically safe explosion-proof construction (II 1G Ex ia II CT4/T5/T6)

### With internal opening indicator plate



#### Internal opening indicator plate

Opening indicator plate inside body

### Body with LCD window

(Smart Positioner)



#### LCD window

Allows checking of control from outside body

### Electro-Pneumatic Positioner

Universal mechanically controlled type  
**Series IP8000/8100**



**IP8000**  
(Lever type)



**IP8100**  
(Rotary type)

### Smart Positioner

Electronically controlled easy-adjustment transmitting type  
**Series IP8001/8101**



**IP8001**  
(Lever type)



**IP8101**  
(Rotary type)

# Smart Positioner

Series **IP8001/8101**

**Built-in microcomputer and sensor allows easy remote parameter change and monitoring.**

- Internal push button for easy setting of various parameters (Refer to parameter list)
- Zero point/span adjustment easier than with previous mechanical positioners

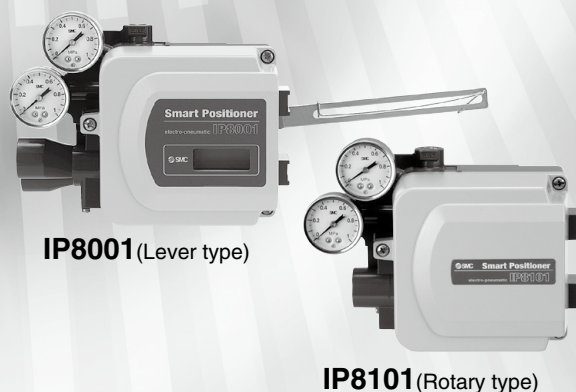

Positioners

Regulators

Relays/Valves

Electro-Pneumatic Transducers

Actuators

Detection Conversion Unit

Solenoid Valves

Air Preparation Equipment

Industrial Filters

Piping Materials

Parameter List

Notes	No	Parameter	Description
Standard equipped functions	1	Positive operation/reverse operation setting	Change operation direction with regard to input signal Change to internal components, piping not possible
	2	Split range setting	Change range of input signal
	3	Preferred zero point/span adjustment setting	Change actuator stroke range with regard to input signal
	4	Forced full close/full open setting	To ensure valve closure, force actuator opening to be 0% or 100% with a preferred input signal.
	5	Valve characteristic setting	Select from these 6 valve characteristics Linear characteristic Equality % characteristic (2 kinds) Quick open characteristic (2 kinds) User preferred point setting (11 points)
	6	PID constant setting	Change PID constant
	7	Calibration setting	Zero point/span adjustment, Auto PID constant setting, input signal display value calibration, etc.
Optional equipped functions	8	Alarm 1 output setting	Set upper/lower stroke limits for actuator from which alarm is output
	9	Alarm 2 output setting	Set upper/lower stroke limits for actuator from which alarm is output
	10	Analog (4 to 20 mA DC) output setting	Set increase/decrease direction for 4 to 20 mA DC output with regard to actuator stroke

## Full Output Functions

Selecting models with output functions by model selection selects with alarm point output function (2 points) and analog (4 to 20 mA DC) continuous output function. This will allow remote detection of operating abnormalities.

## Control State Display

Positioning, deviation, and input value are displayed (numerically) on the internal LCD, allowing visual verification of the control state.

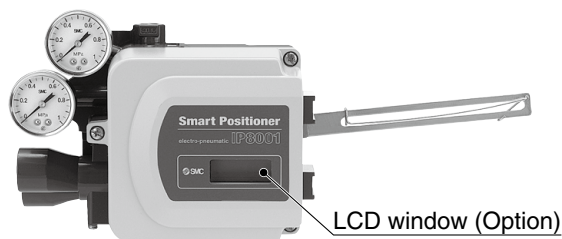

Display example

Positioning (%)	Input value (%)	Deviation (%)
P 50.0	S 60.0	E 10.0

## Handles 2-line Input for Existing Equipment

Control furnished with conventional 2-line input signal (4 to 20 mA DC) not requiring separate power source.

## HART Transmission Function

HART transmission function can be designated by model selection. Allows remote monitoring and setting change of positioner.

## Intercompatible Installation

Dimensions of mounting parts same as previous mechanical series IP6000/IP8000 Electro-Pneumatic Positioner. External feedback lever and fork lever-type fitting for joining actuator and positioner are therefore also the same.

## Energy Saving Product

Lever-type features 60% reduced air flow consumption compared with IP8000.



# Smart Positioner (Lever type/Rotary type)



# Series IP8001/8101

- Auto calibration
- Enclosure: JISF8007 IP65(conforms to IEC 60529)
- Explosion-proof construction/ATEX intrinsically safe explosion-proof construction (II 1G Ex ia II CT4/T5/T6)
- HART transmission function
- Monitoring function

## How to Order

**ATEX Directive Intrinsically Safe Explosion proof**

**Standard**

**Lever type IP8001**

**Rotary type IP8101**

**Type**

001	Smart lever type
101	Smart rotary type

**Pressure gauge**

Symbol	Pressure gauge	Applicable model	
		IP8001	IP8101
1	0.2 MPa	●	—
2	0.3 MPa	●	—
3	1.0 MPa	●	●

**Specifications**

0	Basic type
2	With output function {Analog (4 to 20 mA DC) output + Alarm output x 2}
3	With HART transmission function

**ATEX directive compliance**

52	ATEX directive category 1 Intrinsically safe explosion-proof item
----	----------------------------------------------------------------------

**ATEX temperature**

Symbol	ATEX temperature	Applicable model	
		IP8001	IP8101
Nil	T4	●	●
T6	T5/T6	●	●

**CE marking**

Nil	—
Q	CE marked product

**Connection**

Symbol	Air	Electric
Nil	Rc1/4	G1/2
M <sup>Note)</sup>	Rc1/4	M20 x 1.5
N	Rc1/4	1/2NPT
1	1/4NPT	G1/2
2 <sup>Note)</sup>	1/4NPT	M20 x 1.5
3	1/4NPT	1/2NPT
4	G1/4	G1/2
5 <sup>Note)</sup>	G1/4	M20 x 1.5
6	G1/4	1/2NPT

<sup>Note)</sup> When the symbol is M, 2, or 5 for 52-ATEX directive items, a blue cable gland is included with the electrical connection.

**Accessories** <sup>Note 1)</sup>

Symbol	Accessories	Applicable model	
		IP8001	IP8101
Nil	None (Standard)	●	●
C	Fork lever-type fitting M	—	●
D	Fork lever-type fitting S	—	●
E	For stroke 35 to 100 mm with lever unit <sup>Note 2)</sup>	●	—
F	For stroke 50 to 140 mm with lever unit <sup>Note 2)</sup>	●	—
H	With external scale plate <sup>Note 3)</sup>	—	●
W	Body with LCD window	●	●

**Specifications**

4	Intrinsically safe explosion proof (ATEX) + output function + HART transmission function
---	------------------------------------------------------------------------------------------

Note 1) If two or more accessories are required, the part numbers should be given in alphabetical order. (ex. IP8101-010-CH)  
 Note 2) Standard lever is not attached.  
 Note 3) For side mounting, select "-W" and check the control position by viewing the LCD display value.

Positioners  
Regulators  
Relays/Valves  
Electro-Pneumatic Transducers  
Actuators  
Detection Conversion Unit  
Solenoid Valves  
Air Preparation Equipment  
Industrial Filters  
Piping Materials

## Specifications <sup>Note 1)</sup>

Type	IP8000		IP8100		IP8001	IP8101
	Electro-Pneumatic Positioner				Smart Positioner	
	Lever type lever feedback		Rotary type cam feedback		Lever type	Rotary type
Item	Single action	Double action	Single action	Double action	Single action / Double action	
<b>Input current</b>	4 to 20 mA DC (Standard) <sup>Note 2)</sup>					
<b>Min. operating current</b>	—				3.85 mA DC or more	
<b>Intra-terminal voltage</b>	—				12 V DC (equivalent to 600 Ω input resistance, at 20 mA DC)	
<b>Max. supplied power</b>	—				1 W (Imax: 100 mA DC, Vmax: 28 V DC)	
<b>Input resistance</b>	235 ± 15 Ω (4 to 20 mA DC)				—	
<b>Supply air pressure</b>	0.14 to 0.7 MPa				0.3 to 0.7 MPa	
<b>Standard stroke</b>	10 to 85 mm (Allowable deflection angle 10 to 30°)		60 to 100° <sup>Note 3)</sup>		10 to 85 mm (Allowable deflection angle 10 to 30°) 60 to 100° <sup>Note 3)</sup>	
<b>Sensitivity</b> <sup>Note 4)</sup>	Within 0.1% F.S.		Within 0.5% F.S.		Within 0.2% F.S.	
<b>Linearity</b> <sup>Note 4)</sup>	Within ±1% F.S.		Within ±2% F.S.		Within ±1% F.S.	
<b>Hysteresis</b> <sup>Note 4)</sup>	Within 0.75% F.S.		Within 1% F.S.		Within 0.5% F.S.	
<b>Repeatability</b> <sup>Note 4)</sup>	Within ±0.5% F.S.					
<b>Coefficient of temperature</b>	Within 0.1% F.S./°C				Within 0.05% F.S./°C	
<b>Supply pressure fluctuation</b>	Within 0.3% F.S./0.01 MPa				— <sup>Note 5)</sup>	
<b>Output flow</b> <sup>Note 6)</sup>	80 L/min (ANR) or more (SUP = 0.14 MPa)				200 L/min (ANR) or more (SUP = 0.4 MPa)	
<b>Air consumption</b> <sup>Note 6)</sup>	5 L/min (ANR) or less (SUP = 0.14 MPa) 11 L/min (ANR) or less (SUP = 0.4 MPa)		2 L/min (ANR) or less (SUP = 0.14 MPa) 4 L/min (ANR) or less (SUP = 0.4 MPa)		11 L/min (ANR) or less (SUP = 0.4 MPa)	
<b>Ambient and fluid temperature</b>	General structure: -20 to 80°C					
	TIIS explosion-proof: -20 to 60°C ATEX intrinsically safe explosion-proof: -20 to 80°C (T5) -20 to 60°C (T6) -40 to 60°C (T6)/-L type low-temperature specification			ATEX intrinsically safe explosion-proof -20 to 80°C (T4/T5) -20 to 60°C (T6)		
<b>Explosion proof construction</b> <sup>Note 7)</sup>	TIIS explosion-proof construction (Exd II BT5) ATEX intrinsically safe explosion-proof construction (II 2G Ex ib II CT5/T6)				ATEX intrinsically safe explosion-proof construction (II 1G Ex ia II CT4/T5/T6)	
<b>ATEX intrinsically safe explosion-proof parameter (current circuit)</b>	Ui ≤ 28 V, li ≤ 125 mA, Pi ≤ 1.2 W Ci ≤ 0 nF, Li ≤ 0 mH				Ui ≤ 28 V, li ≤ 100 mA, Pi ≤ 0.7 W Ci ≤ 12.5 nF, Li ≤ 1.5 mH	
<b>Exterior covering enclosure</b> <sup>Note 8)</sup>	JISF8007, IP65 (conforms to IEC Pub.60529)					
<b>Transmission method</b> <sup>Note 7)</sup>	—				HART transmission	
<b>Air connection port</b> <sup>Note 9)</sup>	Rc 1/4 female thread, NPT 1/4 female thread, G 1/4 female thread					
<b>Electrical connection port</b> <sup>Note 9)</sup>	G 1/2 female thread, M20 x 1.5 female thread, NPT 1/2 female thread					
<b>Material/coating</b>	Aluminum diecast body/baking finish with denatured epoxy resin					
<b>Weight</b>	2.4 kg (Without terminal box)/2.6 kg (With terminal box)				2.6 kg	

Note 1) Specification values are given at normal temperature (20°C).

Note 2) 1/2 Split range (Standard)

Note 3) Stroke adjustment: 0 to 60°, 0 to 100°

Note 4) Characteristics relating to accuracy differ depending on combination with other constituent loop equipment, such as positioners and actuators.

Note 5) While there is no output changes due to pressure fluctuations, when the pressure supply setting is changed following calibration, once again adjust balance current and perform calibration.

Note 6) (ANR) indicates JIS B0120 standard air.

Note 7) Model selection required for explosion proof construction and HART transmission.

Note 8) For IP66 compliant products, refer to pages 25 to 28.

Note 9) Thread type can be specified by model selection.

## Optional Specifications

Item	Type	IP8100-0 <input type="checkbox"/> 1-J/JR (Non-explosion proof)	IP8 <input type="checkbox"/> 01-0 <input type="checkbox"/> 2 (Non-explosion proof)	52-IP8 <input type="checkbox"/> 01-0 <input type="checkbox"/> 4	
		Electro-Pneumatic Positioner	Smart Positioner		
<b>Analog output</b>	<b>Wiring</b>	2-line			
	<b>Output signal</b>	4 to 20 mA DC			
	<b>Power supply voltage</b>	12 to 35 V DC	10 to 28 V DC		
	<b>Load resistance</b>	(Power supply voltage - 12 V) ÷ 20 mA DC or less	0 to 750 Ω		
	<b>Accuracy</b>	±2% F.S. or less <sup>Note 1)</sup>	±0.5% F.S. or less <sup>Note 2)</sup>		
	<b>Hysteresis</b>	Within 1% F.S.	—		
<b>Alarm output 1, 2</b>	<b>Wiring</b>	—	2-line		
	<b>Applicable standards</b>	—	—	DIN19234/NAMUR Standard	
	<b>Power supply voltage</b>	—	10 to 28 V DC	5 to 28 V DC	
	<b>Load resistance</b>	—	10 to 40 mA DC	(Constant current output)	
	<b>Alarm ON</b>	—	R = 350 Ω ±10%	≥ 2.1 mA DC	
	<b>Alarm OFF (Leakage current)</b>	—	0.5 mA DC or less	≤ 1.2 mA DC	
	<b>Response time</b>	—	50 msec or less		

Note 1) Indicates analog output accuracy with respect to actuator angle.

Note 2) Indicates analog output accuracy with respect to LCD display position value (P value).

## Accessory/Option

### Pilot valve with output restriction (IP8000/8100)

In general, mounting on a small-size actuator may cause hunting. For prevention, a pilot valve with a built-in output restriction is available. The restriction is removable.

Actuator capacity	Orifice size	Part number	Pilot unit part number	Model selection accessory
90 cm <sup>3</sup>	ø0.7	P36801080	P565010-18	A
180 cm <sup>3</sup>	ø1	P36801081	P565010-19	B

Note) Output orifice not required for Smart Positioner regardless of actuator capacity.

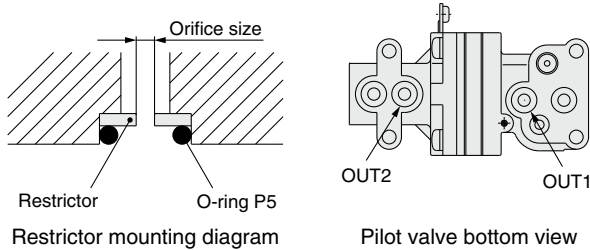

### Fork lever-type fittings (IP8100/8101)

2 kinds of rotary type IP8100/8101 fork lever-type fittings, that differ by installation dimensions dependent on bracket installation method, and 2 kinds of installation portion thread sizes, are available.

When installing on the side surface, using fork lever assembly M provides interchangeability with the installation dimensions of SMC IP610 positioner. When installing on the rear surface, using fork lever assembly S also provides interchangeability with the installation dimensions of SMC IP610 positioner.

Part name	Unit number	Installation portion thread size	Model selection accessory
Fork lever assembly M	P368010-24	M8 x 1.25	C
Fork lever assembly S	P368010-25		D
Fork lever assembly MX	P368010-36	M6 x 1	C (Note)
Fork lever assembly SX	P368010-37		D (Note)

Note) Installation portion thread size is M6 x 1 for IP8100-0 -X14 when accessory C or D are selected.

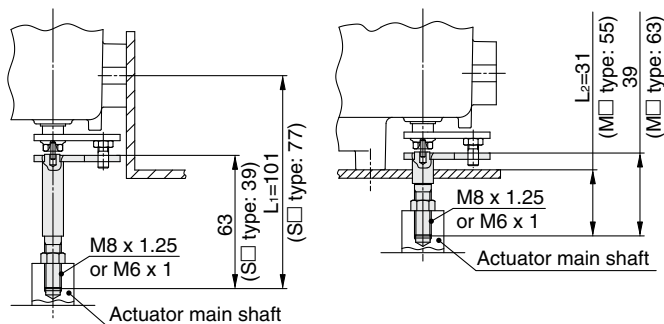

Side mounting with the fork lever assembly M  

Rear mounting with the fork lever assembly S  

### External feedback lever (IP8000/8001)

Different feedback levers are available dependent upon valve strokes. Order according to the valve stroke.

#### Feedback lever types

Stroke	Unit number		Size M	Size N	Model selection accessory
	IP8000	IP8001			
10 to 85 mm	P368010-20	P565010-323	125	150	Standard accessory
35 to 100 mm	P368010-21	P565010-324	110	195	E
50 to 140 mm	P368010-22	P565010-325	110	275	F
6 to 12 mm	P368010-260	P565010-329	75	75	Available as special order

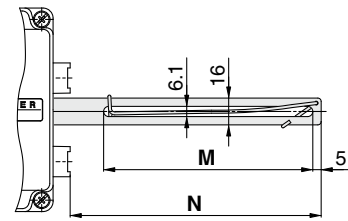

### Resin connector (Non-explosion proof specification)

Optional cable connectors are available for different cable sizes. These are not for explosion proof applications. Recommended for use with indoor applications.

Part name	Part number	Suited cable outer diameter
Resin-made cable clamp unit (A)	P368010-26	ø7 to ø9
Resin-made cable clamp unit (B)	P368010-27	ø9 to ø11

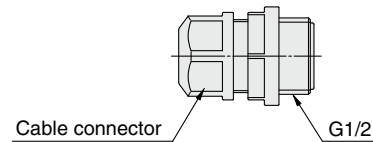

# Series IP8

## Exploded View

### IP8000

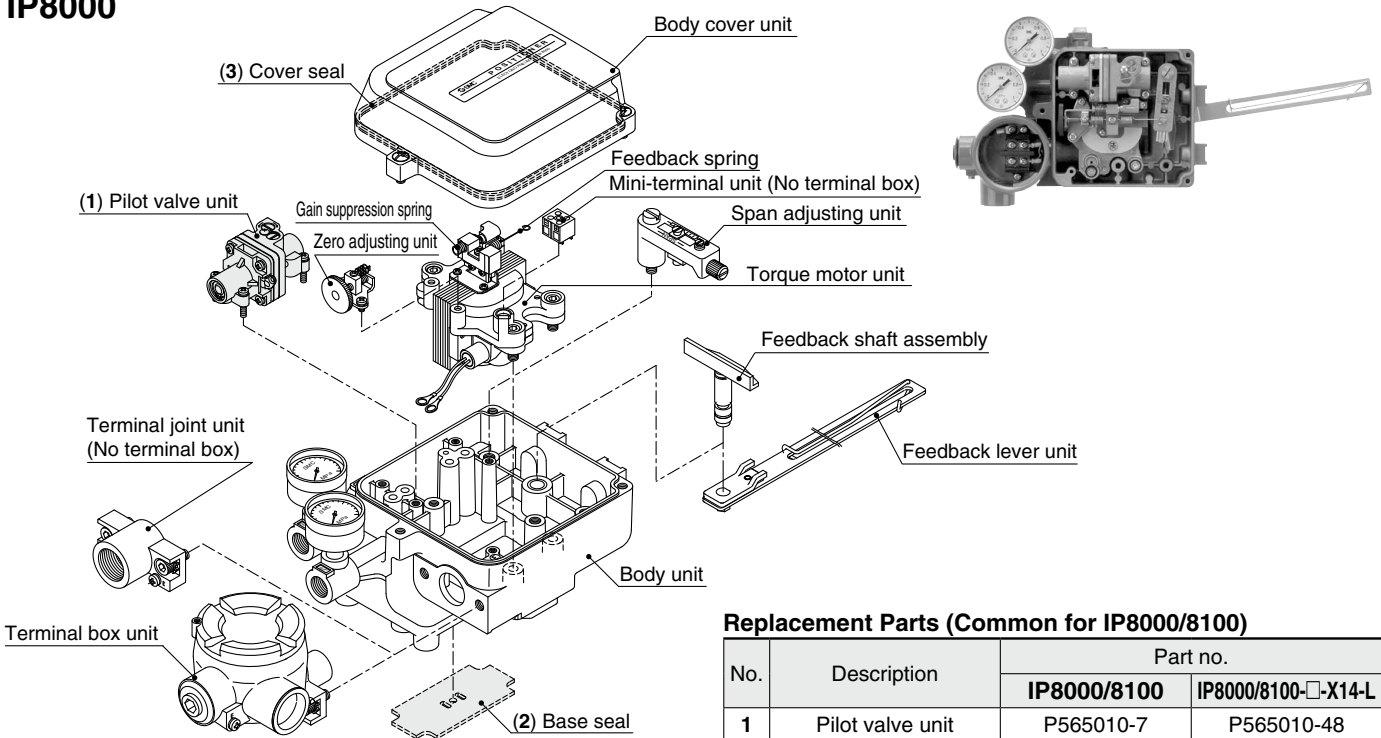

#### Replacement Parts (Common for IP8000/8100)

No.	Description	Part no.	
		IP8000/8100	IP8000/8100- <input type="checkbox"/> -X14-L
1	Pilot valve unit	P565010-7	P565010-48
2	Base seal	P56501012-3	
3	Cover seal	P56501013	

### IP8101

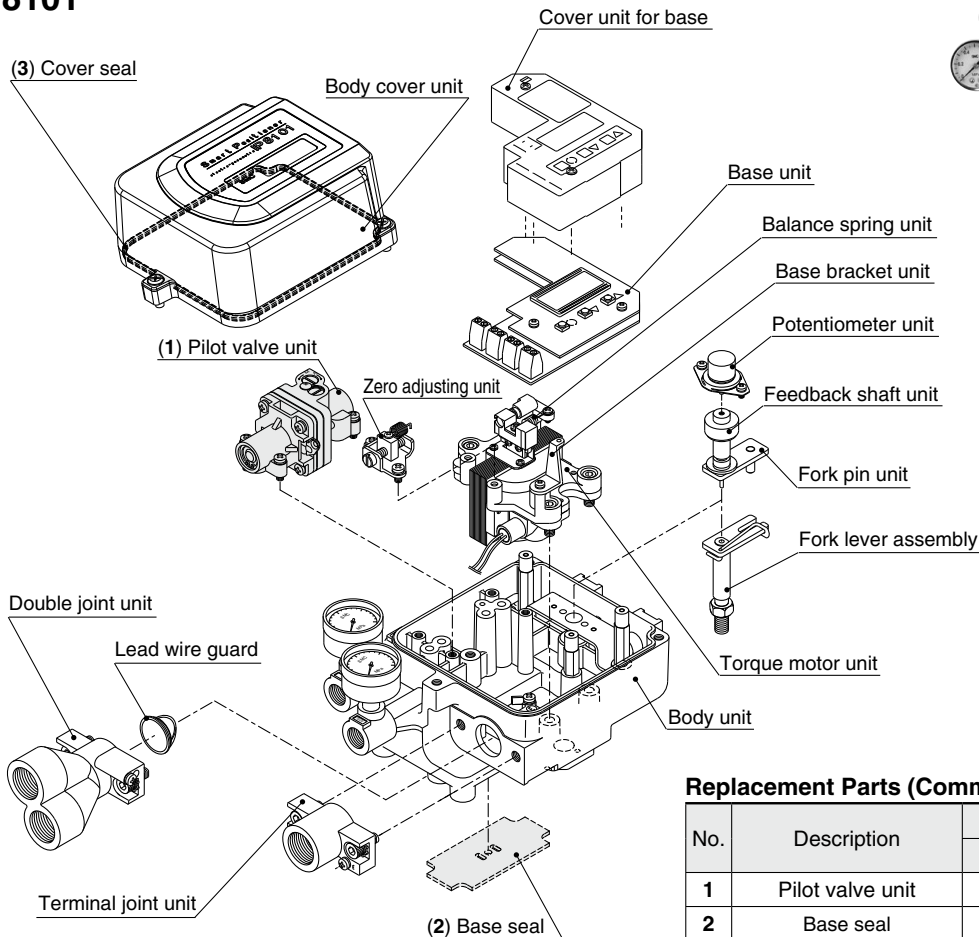

#### Replacement Parts (Common for IP8001/8101)

No.	Description	Part no.	
		IP8001	IP8101
1	Pilot valve unit	P565010-322	P565010-303
2	Base seal	P56501012-3	
3	Cover seal	P56501013	

**Piping** Note) When the input signal is discontinued, the pressure of OUT1 decreases, and the pressure of OUT2 increases.

### IP8000/Lever type

	Single action		Double action	
<b>Positive operation</b>	<p>When the input signal is increased, the stem moves as allow mark.</p> <p>OUT2 is plugged.</p>	<p>When the input signal is increased, the stem moves as allow mark. (Positive valve operation by its reverse operation mode)</p> <p>OUT1 is plugged.</p>	<p>When the input signal is increased, the cylinder rod moves as allow mark.</p> <p>Span adjusting lever normal position</p>	
	<b>Reverse operation</b>	<p>When the input signal is increased, the stem moves as allow mark. (Reverse valve operation by its positive operation mode)</p> <p>OUT1 is plugged.</p>		<p>When the input signal is increased, the stem moves as allow mark.</p> <p>OUT2 is plugged.</p>

### IP8100/Rotary type

	Single action		Double action	
<b>Positive operation</b>	<p>When the input signal is increased, the actuator shaft rotates in a clockwise direction.</p> <p>OUT2 is plugged.</p>	<p>When the input signal is increased, the actuator shaft rotates in a clockwise direction. (Positive valve operation by its reverse operation mode)</p> <p>OUT1 is plugged.</p>	<p>When the input signal is increased, the actuator shaft rotates in a clockwise direction.</p> <p>The cam of the positioner should be set on the DA surface.</p>	
	<b>Reverse operation</b>	<p>When the input signal is increased, the actuator shaft rotates in a counter clockwise direction. (Reverse valve operation by its positive operation mode)</p> <p>OUT1 is plugged.</p>		<p>When the input signal is increased, the actuator shaft rotates in a counter clockwise direction.</p> <p>OUT2 is plugged.</p>

Positioners

Regulators

Relays/Valves

Electro-Pneumatic Transducers

Actuators

Detection Conversion Unit

Solenoid Valves

Air Preparation Equipment

Industrial Filters

Piping Materials



## Piping

Note) When the input signal is discontinued, the pressure of OUT1 decreases, and the pressure of OUT2 increases.  
Caution is also similarly required when changing the control direction in parameter mode.

### IP8001/Lever type

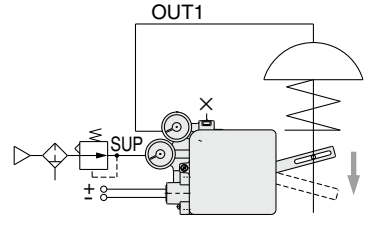
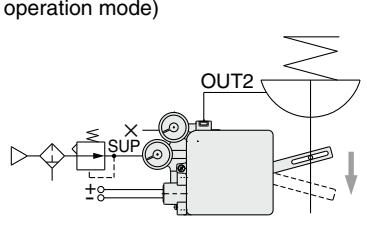
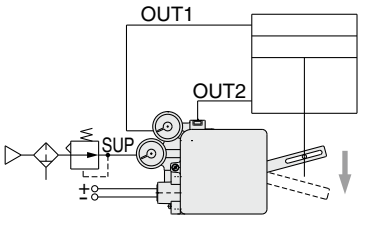
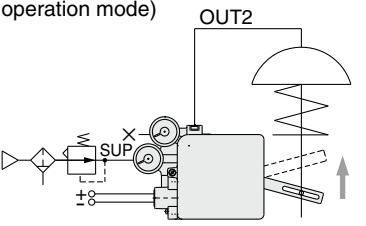
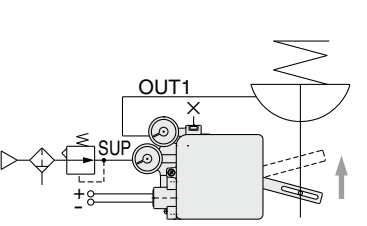
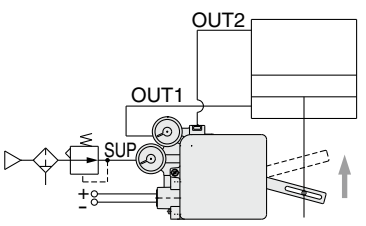
	Single action	Double action	
Positive operation	<p>When the input signal is increased, the stem moves as allow mark.</p>  <p>OUT2 is plugged.</p>	<p>When the input signal is increased, the stem moves as allow mark. (Positive valve operation by its reverse operation mode)</p>  <p>OUT1 is plugged.</p>	<p>When the input signal is increased, the cylinder rod moves as allow mark.</p> 
Reverse operation	<p>When the input signal is increased, the stem moves as allow mark. (Reverse valve operation by its positive operation mode)</p>  <p>OUT1 is plugged.</p>	<p>When the input signal is increased, the stem moves as allow mark.</p>  <p>OUT2 is plugged.</p>	<p>When the input signal is increased, the cylinder rod moves as allow mark.</p> 

### IP8101/Rotary type

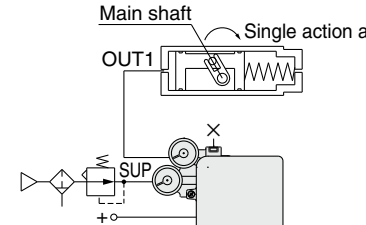
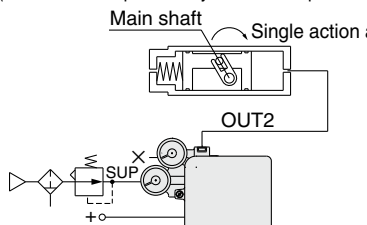
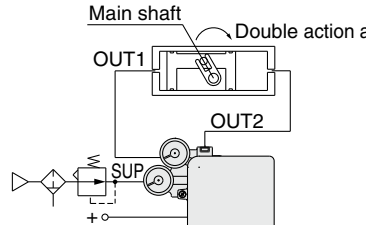
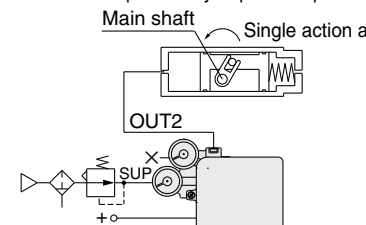
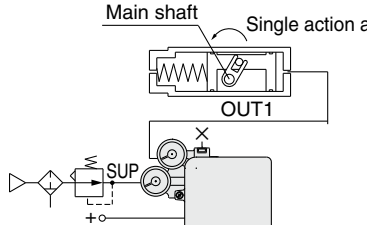
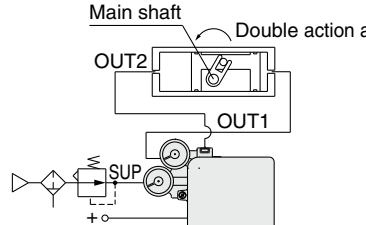
	Single action	Double action	
Positive operation	<p>When the input signal is increased, the actuator shaft rotates in a clockwise direction.</p>  <p>OUT2 is plugged.</p>	<p>When the input signal is increased, the actuator shaft rotates in a clockwise direction. (Positive valve operation by its reverse operation mode)</p>  <p>OUT1 is plugged.</p>	<p>When the input signal is increased, the actuator shaft rotates in a clockwise direction.</p> 
Reverse operation	<p>When the input signal is increased, the actuator shaft rotates in a counter clockwise direction. (Reverse valve operation by its positive operation mode)</p>  <p>OUT1 is plugged.</p>	<p>When the input signal is increased, the actuator shaft rotates in a counter clockwise direction.</p>  <p>OUT2 is plugged.</p>	<p>When the input signal is increased, the actuator shaft rotates in a counter clockwise direction.</p> 

## Installation

### IP8000/8001 (Lever type)

1. Create brackets that are appropriate for the positioner and diaphragm valve mounting methods, and affix it firmly using the mounting hole on the side or rear surface.

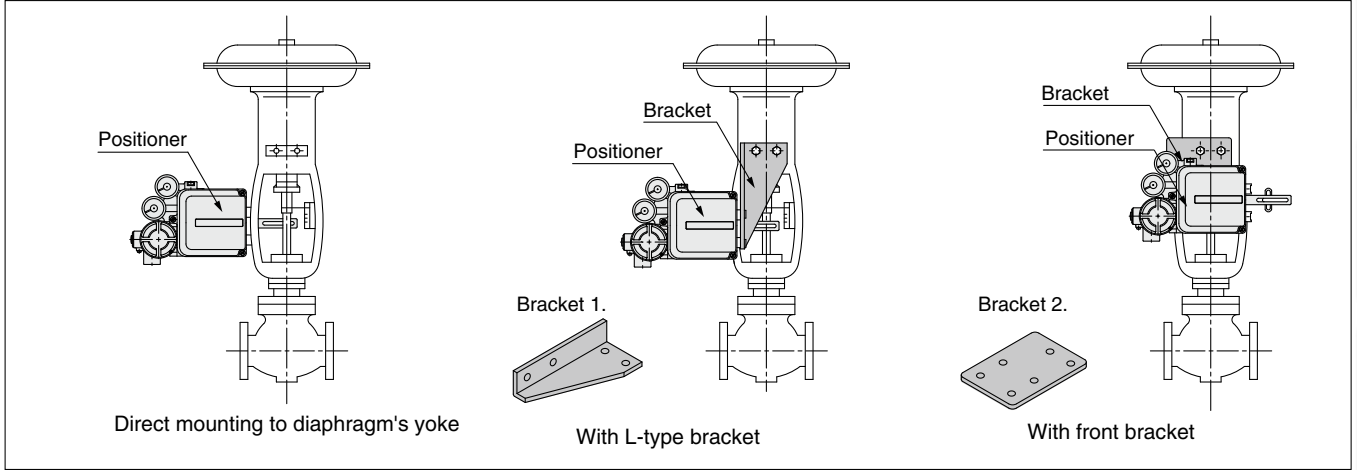

2. The feedback lever that detects the displacement of valve stems should be mounted at a position so that the lever is at right angles to the valve stem for an input current of 50%. The figure is the configuration viewed from the front.

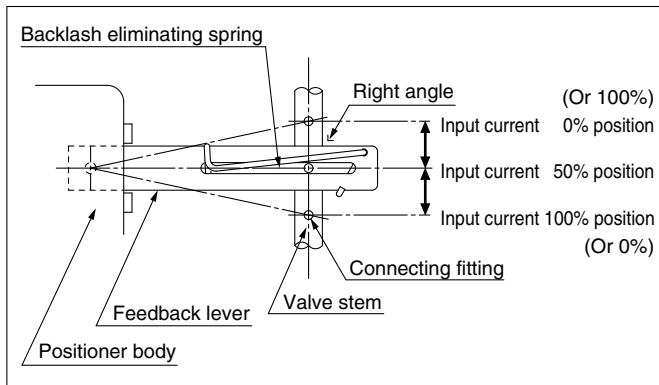

3. Brackets for lever type positioners, which are compliant with NAMUR and DIN/IEC 60534-6-1 are now available.

Description	Part no.
Bracket (NAMUR compliant) single unit	INI-224-0-56

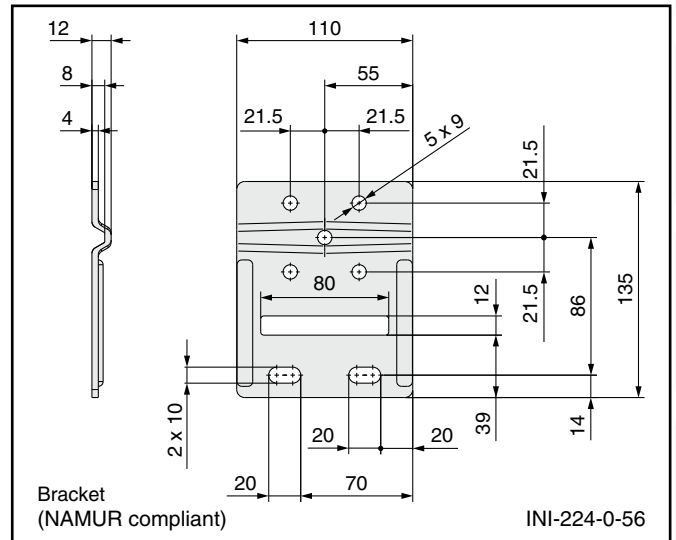

### IP8100/8101 (Rotary type)

1. The positioner should be mounted so that the feedback shaft is aligned with the shaft of the rotary actuator.

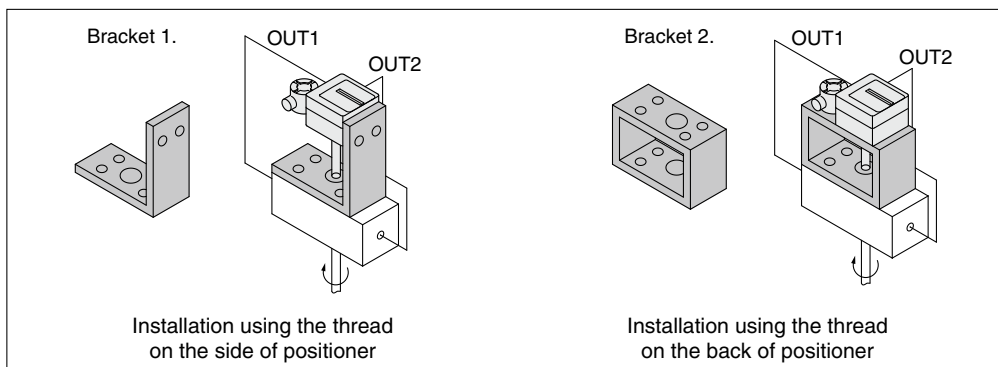

## Principle of Operation

### IP8000/Lever type

When the input current increases, (11) the plate spring of (12) the torque motor will work as a pivot, (13) armature will receive a counter clockwise torque, (4) the counter weight will be pushed to the left, the clearance between (6) the nozzle and (5) the flapper will increase, and the nozzle back pressure will decrease. Consequently, (7) the exhaust valve of (1) the pilot valve moves to the right, the output pressure of OUT1 increases and (15) the diaphragm moves downwards. The motion of (15) the diaphragm acts on (10) the feedback spring through (8) the feedback lever, (14) the transmission lever and (9) the span adjustment lever to rest at the balance position generated by the input current. (2) The gain suppression spring is for direct feedback of the motion of (7) the exhaust valve to (4) the counter weight to increase the stability of the loop. The zero point should be adjusted by change of (3) the zero adjustment spring tension.

### Single action positive operation

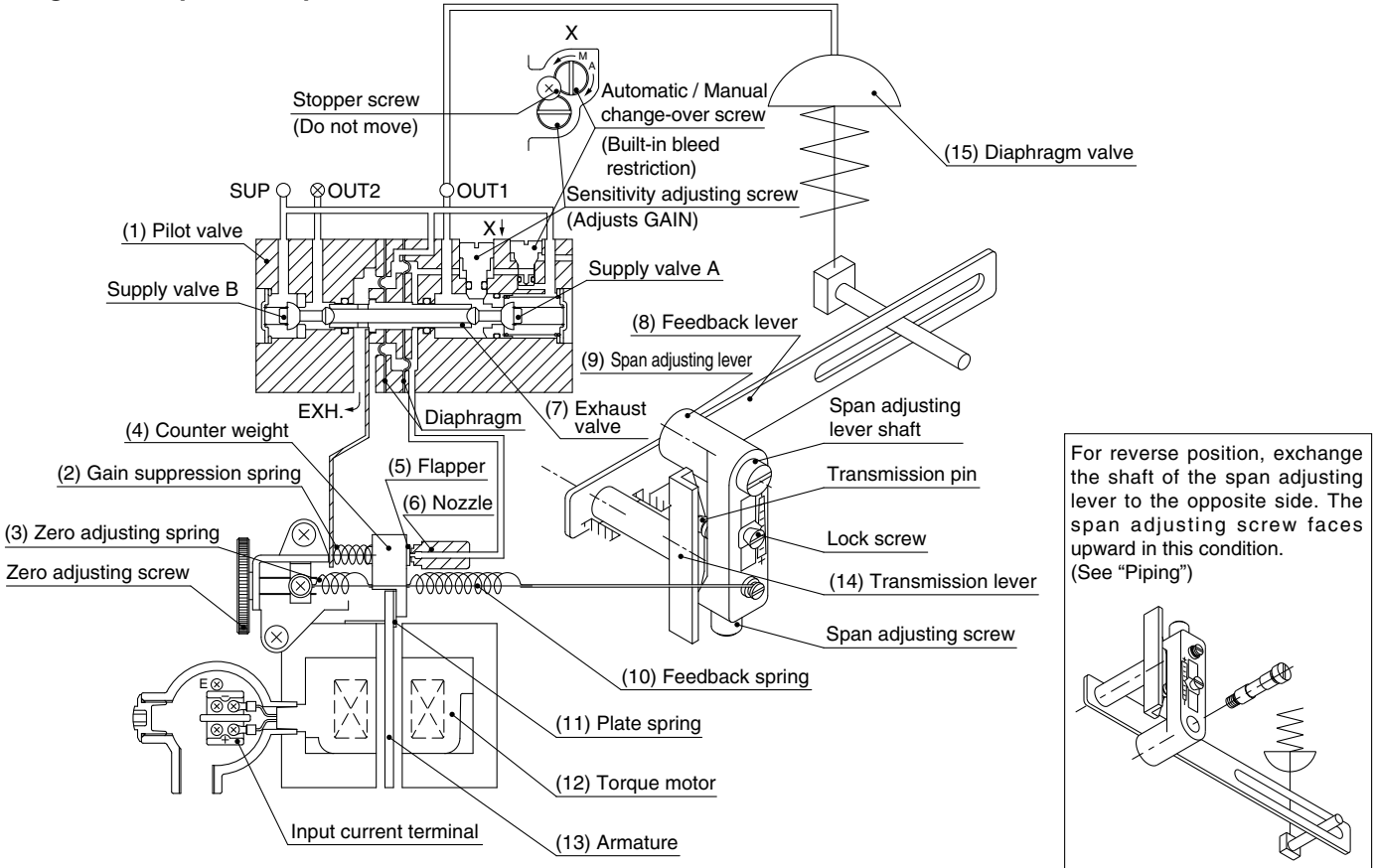

### Block diagram

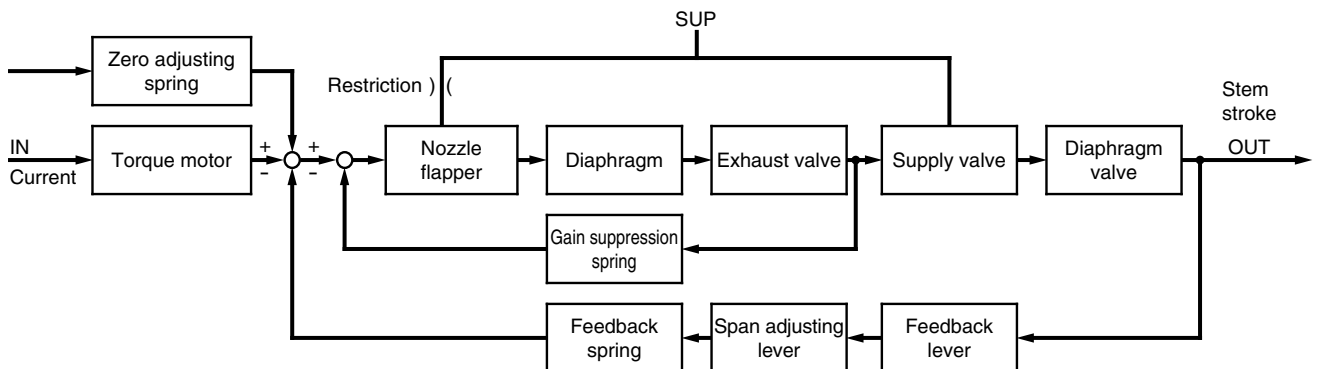

## IP8100/Rotary type

When the input current increases, (12) the plate spring of (13) the torque motor will work as a pivot, (14) armature will receive a counter-clockwise torque, (4) the counter weight will be pushed to the left and the clearance between (6) the nozzle and (5) the flapper will increase, and the nozzle back pressure will decrease. Consequently, (7) the exhaust valve of (1) the pilot valve moves to the right, the output pressure of OUT1 increases that of OUT2 decreases and (16) the rotary actuator moves. The motion of (16) the actuator acts on (10) the feedback spring through (11) the feedback shaft, (8) the cam, (9) the span adjustment lever and (15) transmission lever to rest at the balance position generated by the input current. (8) the cam is set on the DA surface and operates positively while (16) the oscillating actuator shaft rotates in a clockwise direction when the input signal is increased. (2) The gain suppression spring is for direct feedback of the motion of (7) the exhaust valve to (4) the counter weight to increase the stability of the loop. The zero point should be adjusted by change of (3) the zero adjustment spring tension.

### Double action positive operation

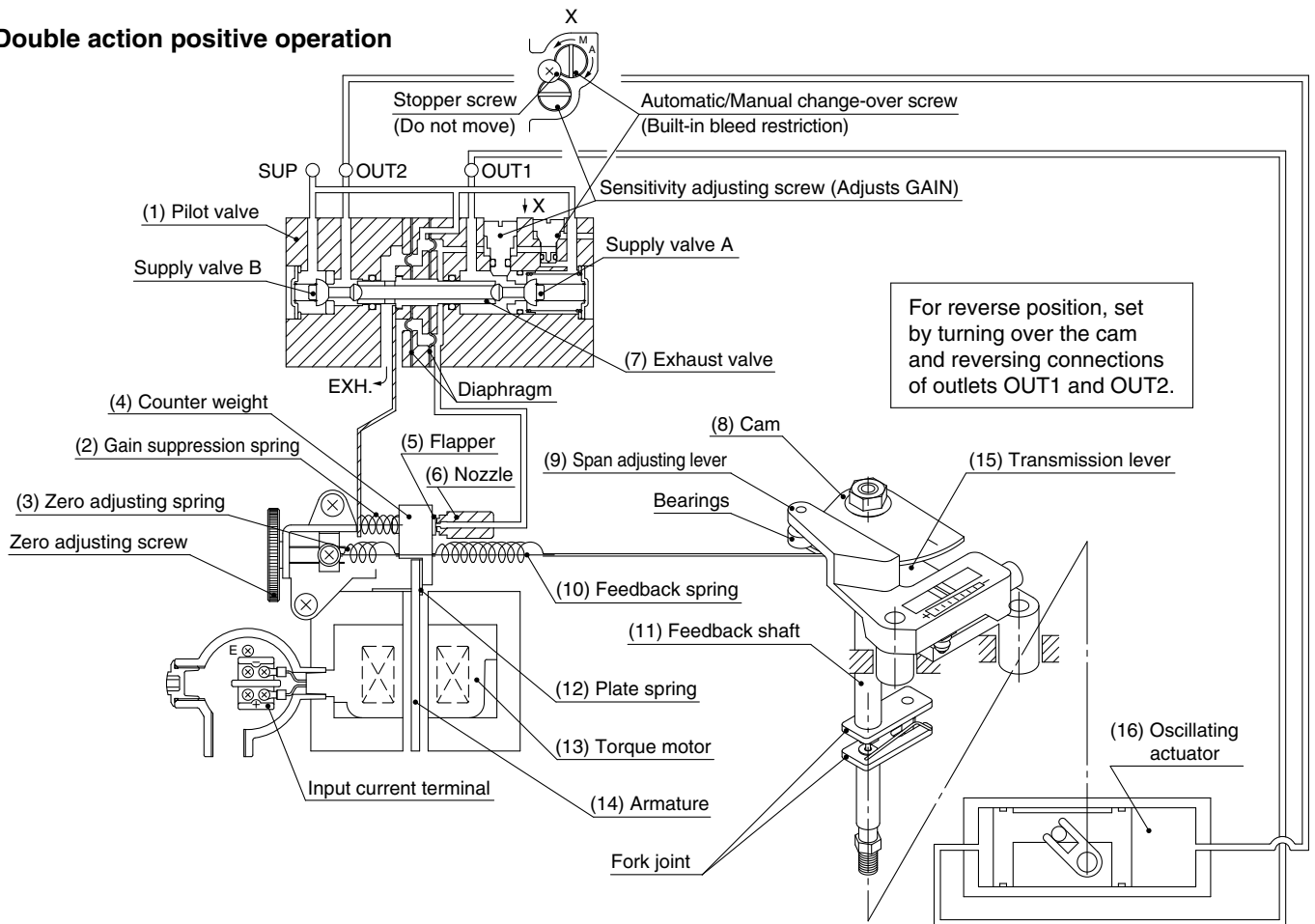

### Block diagram

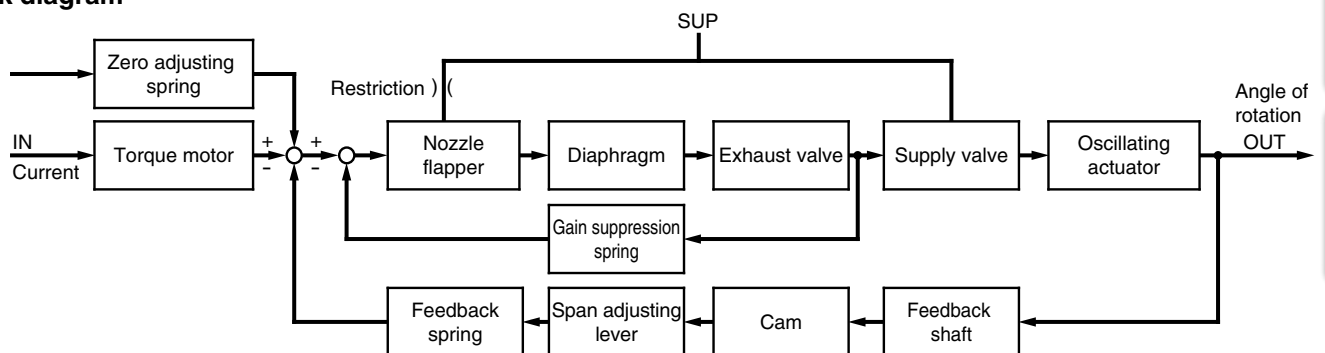

## Principle of Operation

### IP8001/Lever type

When the input current increases, the electrical current inside (12) the torque motor coil will change through (8) the plate's input process, operation process and output process, and (13) the armature will oscillate, with (11) the plate spring as its base. As a result, the clearance between (6) the nozzle and (5) the flapper will increase, and the nozzle back pressure will decrease. Consequently, (7) the exhaust valve of (1) the pilot valve moves to the right, the output pressure of OUT1 increases and causes (15) the diaphragm valve to move. The motion of (15) the diaphragm valve is transmitted to the displacement output process of (8) the board through (14) the feedback lever, (10) the feedback shaft and (9) angle sensor, and the calculated output position will match the input current.

### Single action positive operation

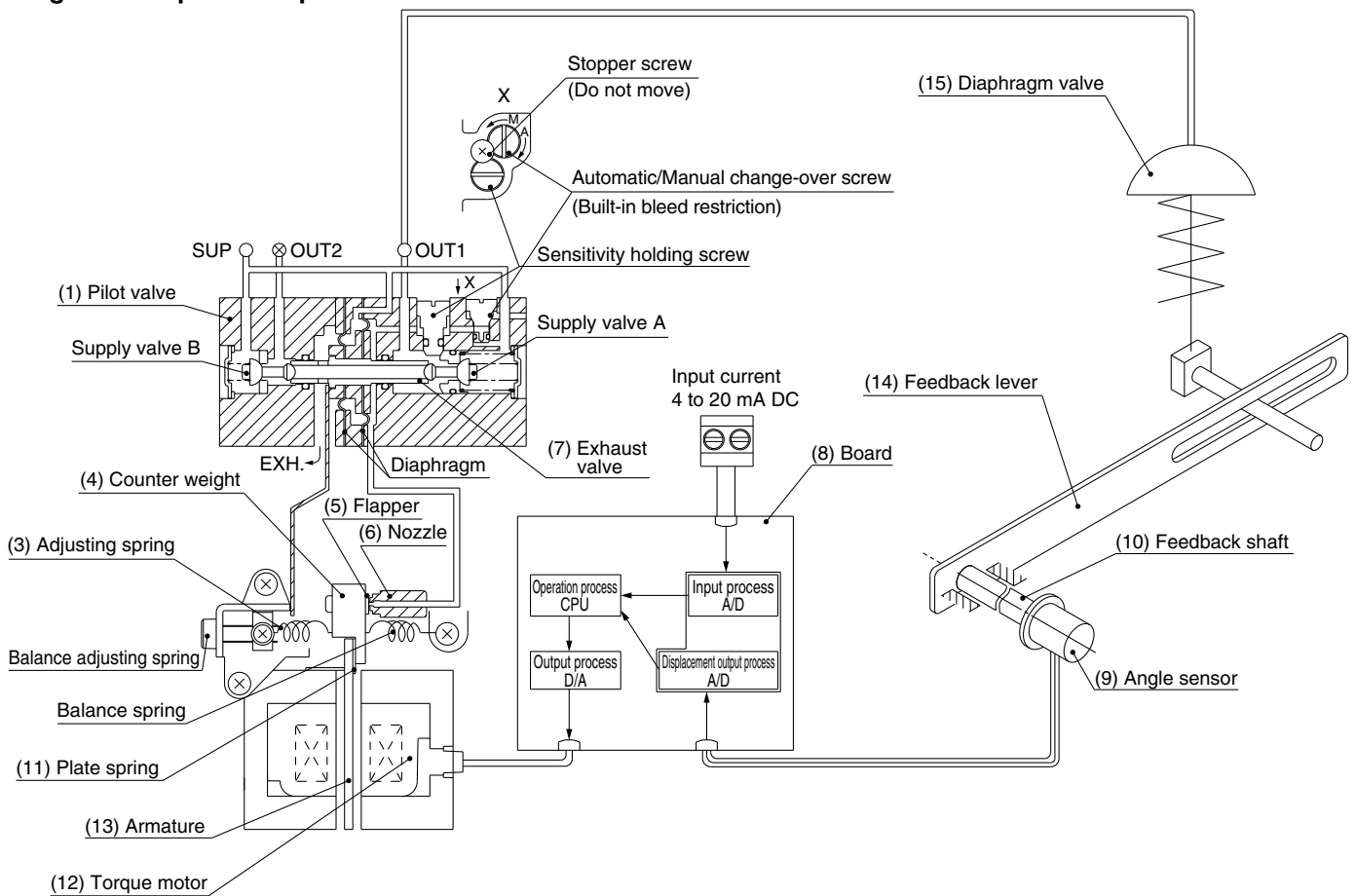

### Block diagram

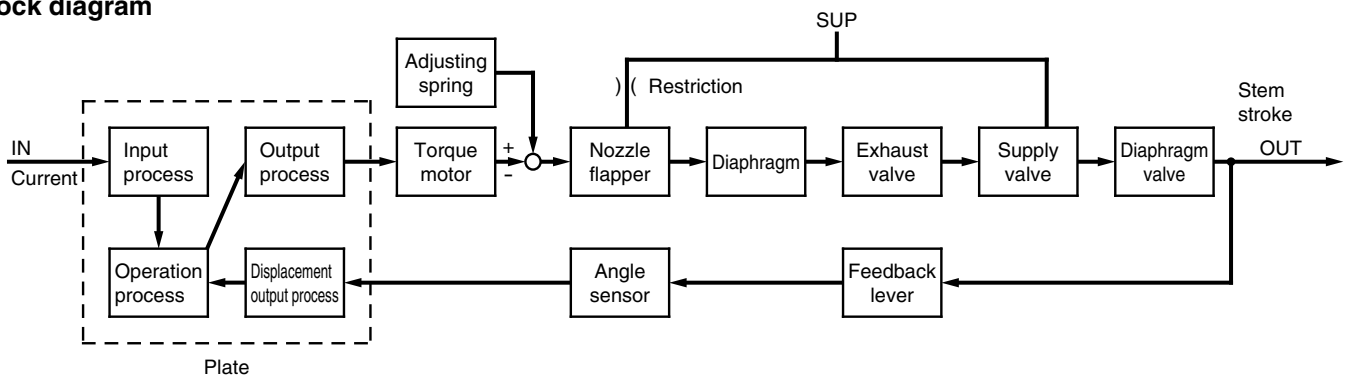

## IP8101/Rotary type

When the input current increases, the electrical current inside (12) the torque motor coil will change through (8) the plate's input process, operation process and output process, and (13) the armature will oscillate, with (11) the plate spring as its base. As a result, the clearance between (6) the nozzle and (5) the flapper will increase, and the nozzle back pressure will decrease. Consequently, (7) the exhaust valve of (1) the pilot valve moves to the right, the output pressure of OUT1 increases and causes the output pressure of OUT2 to decrease, causing (14) the oscillating actuator to move. The motion of (14) the oscillating actuator is transmitted to the fork lever-type fitting, (10) the feedback shaft (9) angle sensor, and the displacement output process of (8) the board, and output position will match the input current.

### Double action positive operation

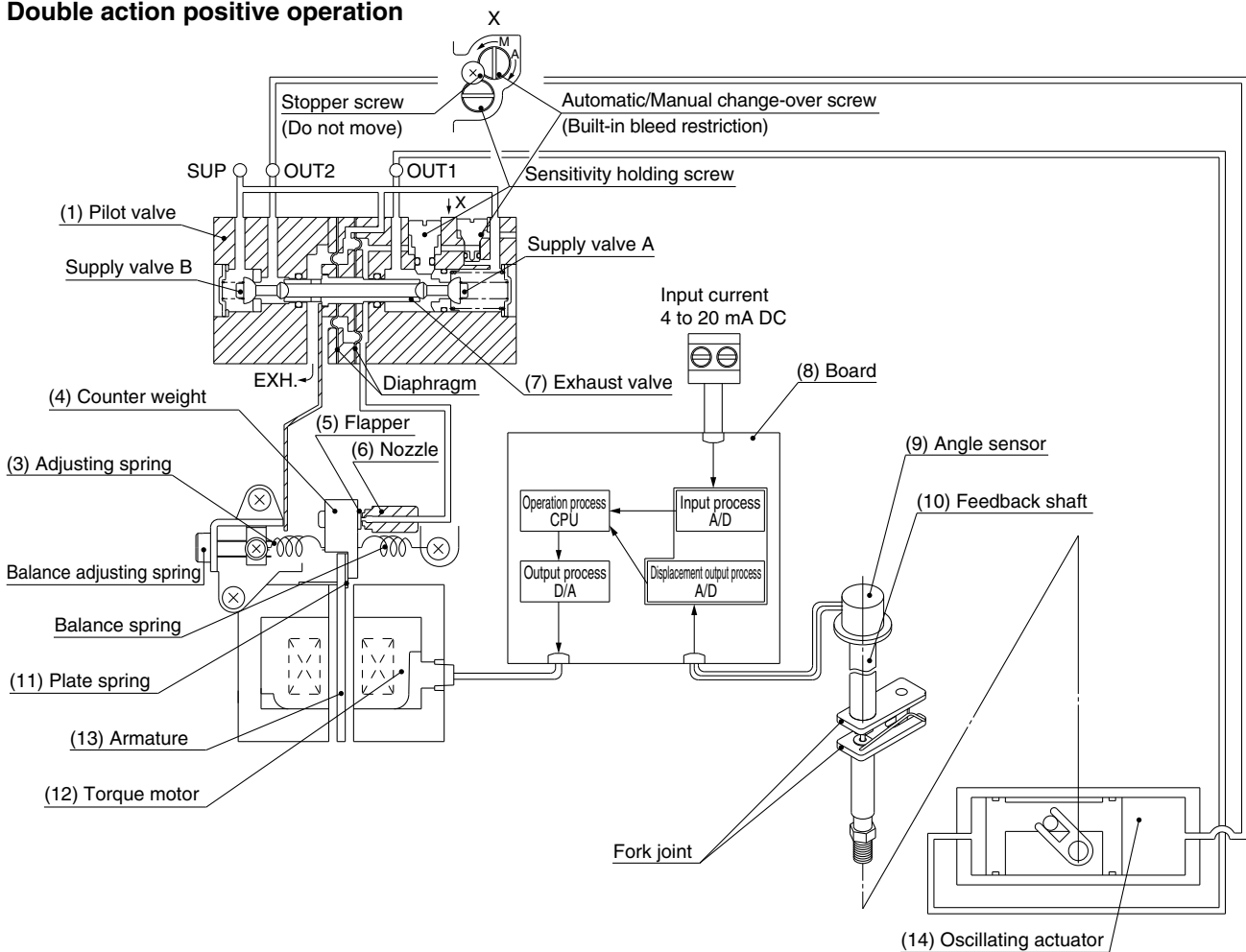

### Block diagram

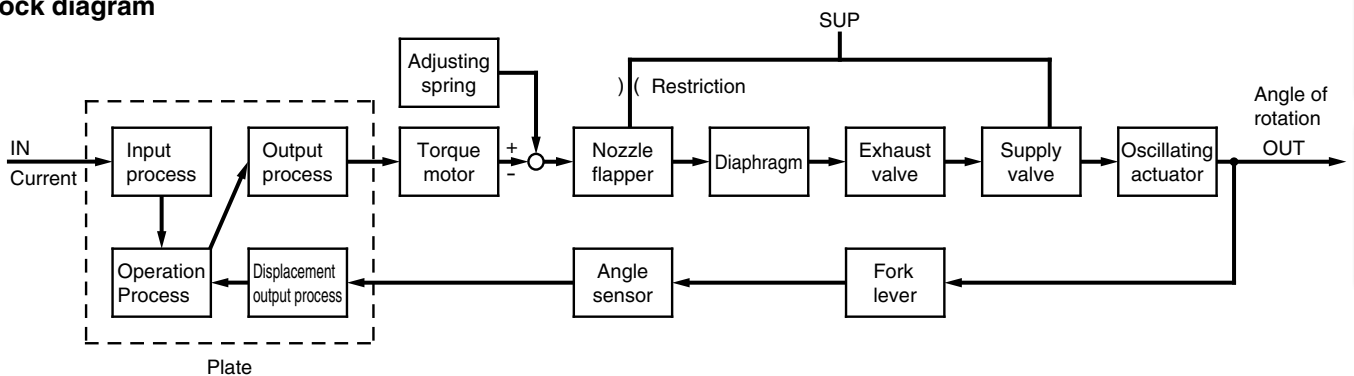

## Dimensions/IP8000 (Lever type)

### IP8000-0□0 (Without terminal box)

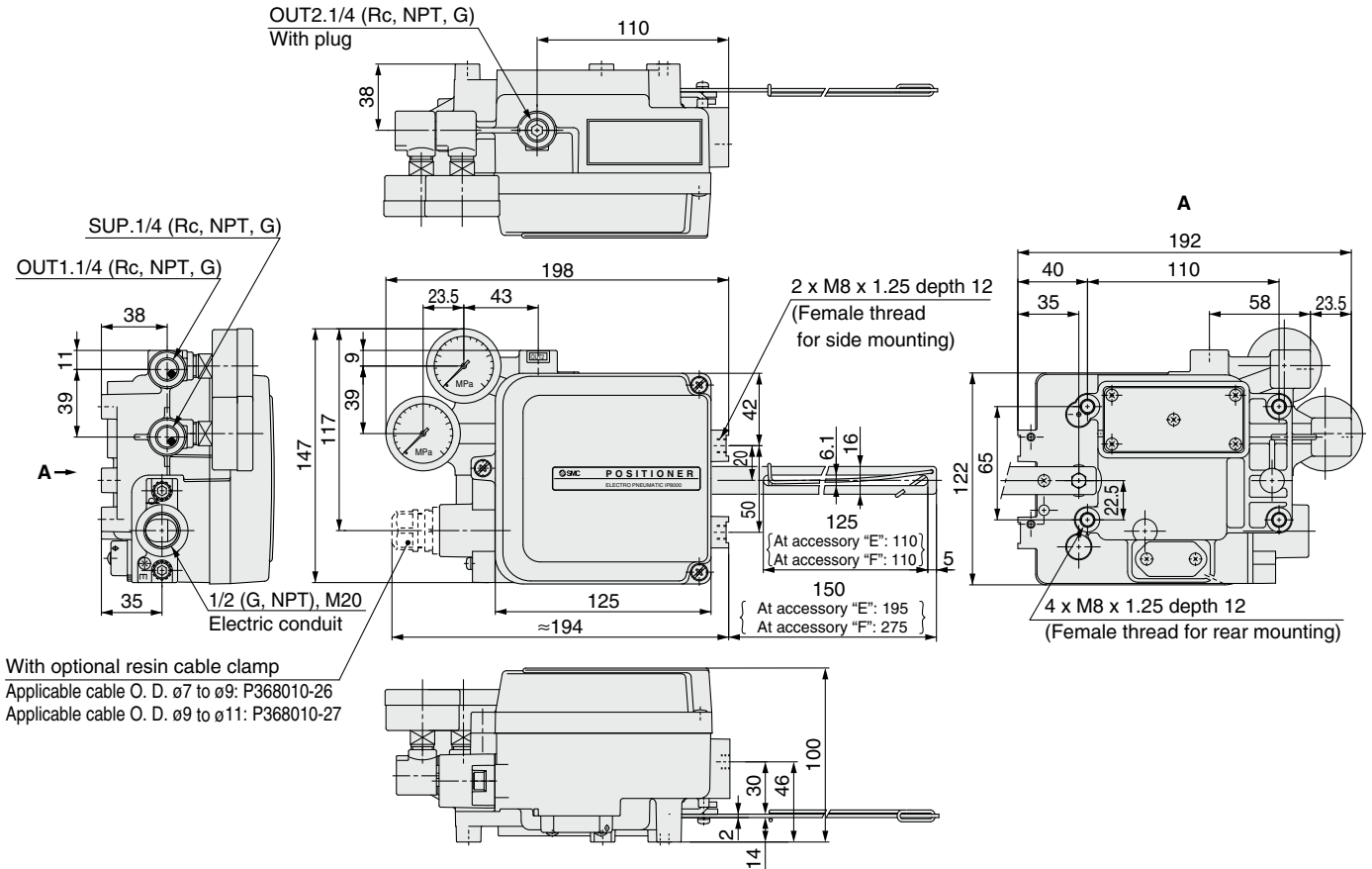

### IP8000-0□1 (With terminal box)

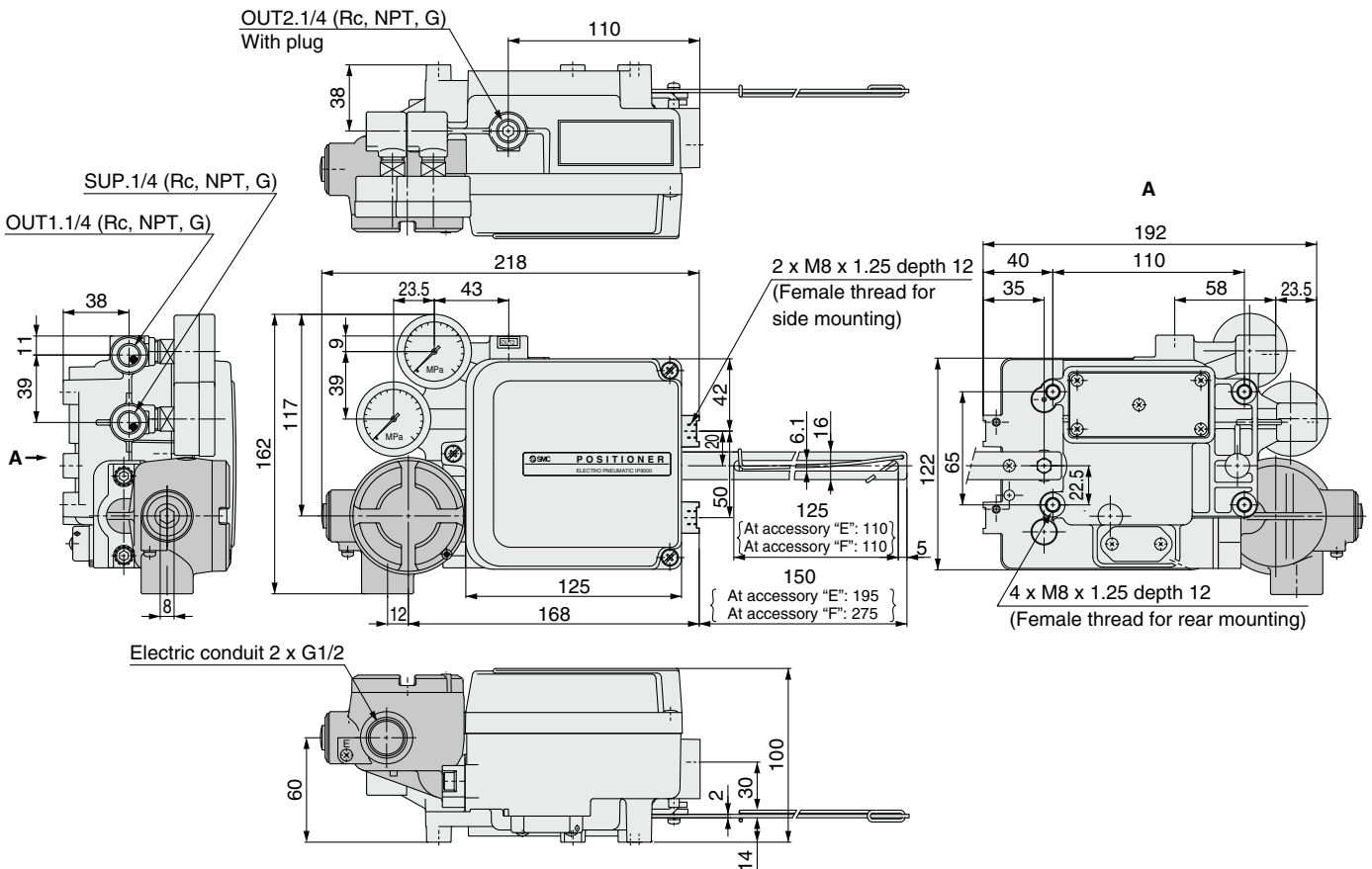

**Dimensions/IP8100 (Rotary type)**

**IP8100-0□0 (Without terminal box)**

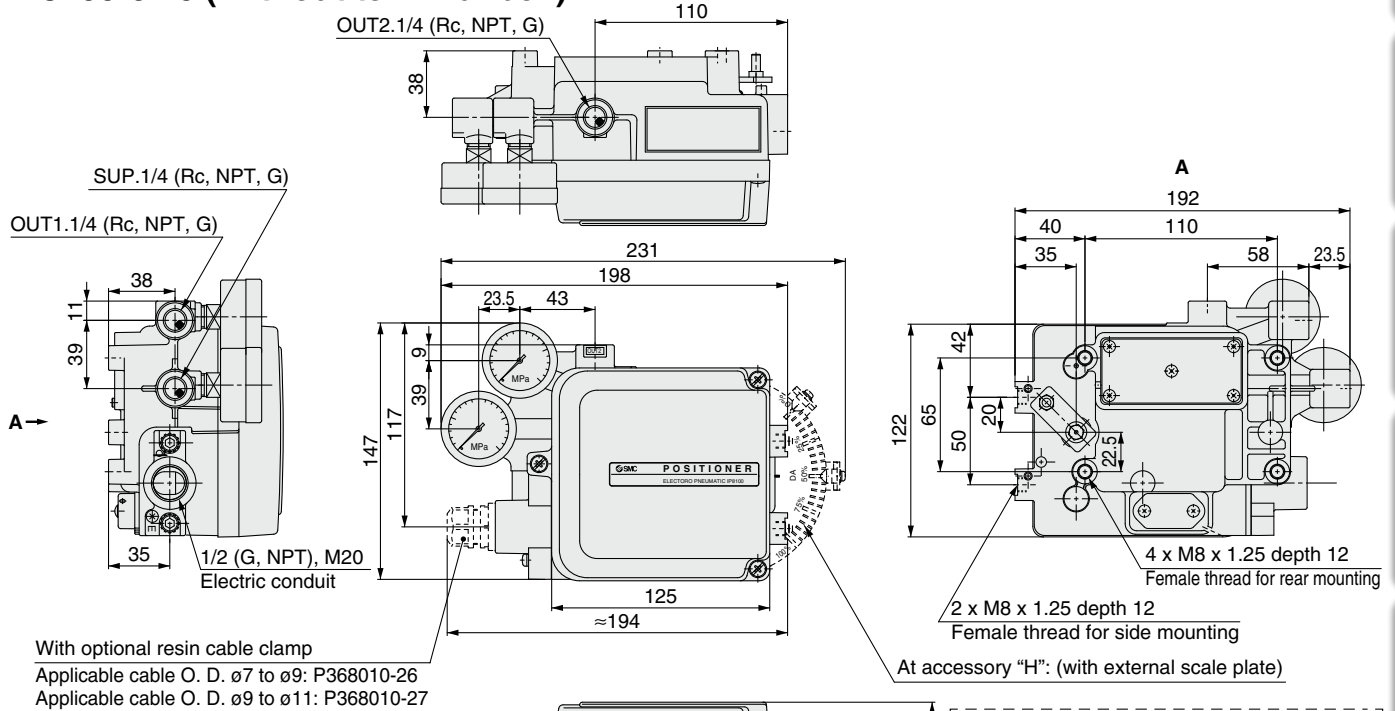

**IP8100-0□1 (With terminal box)**

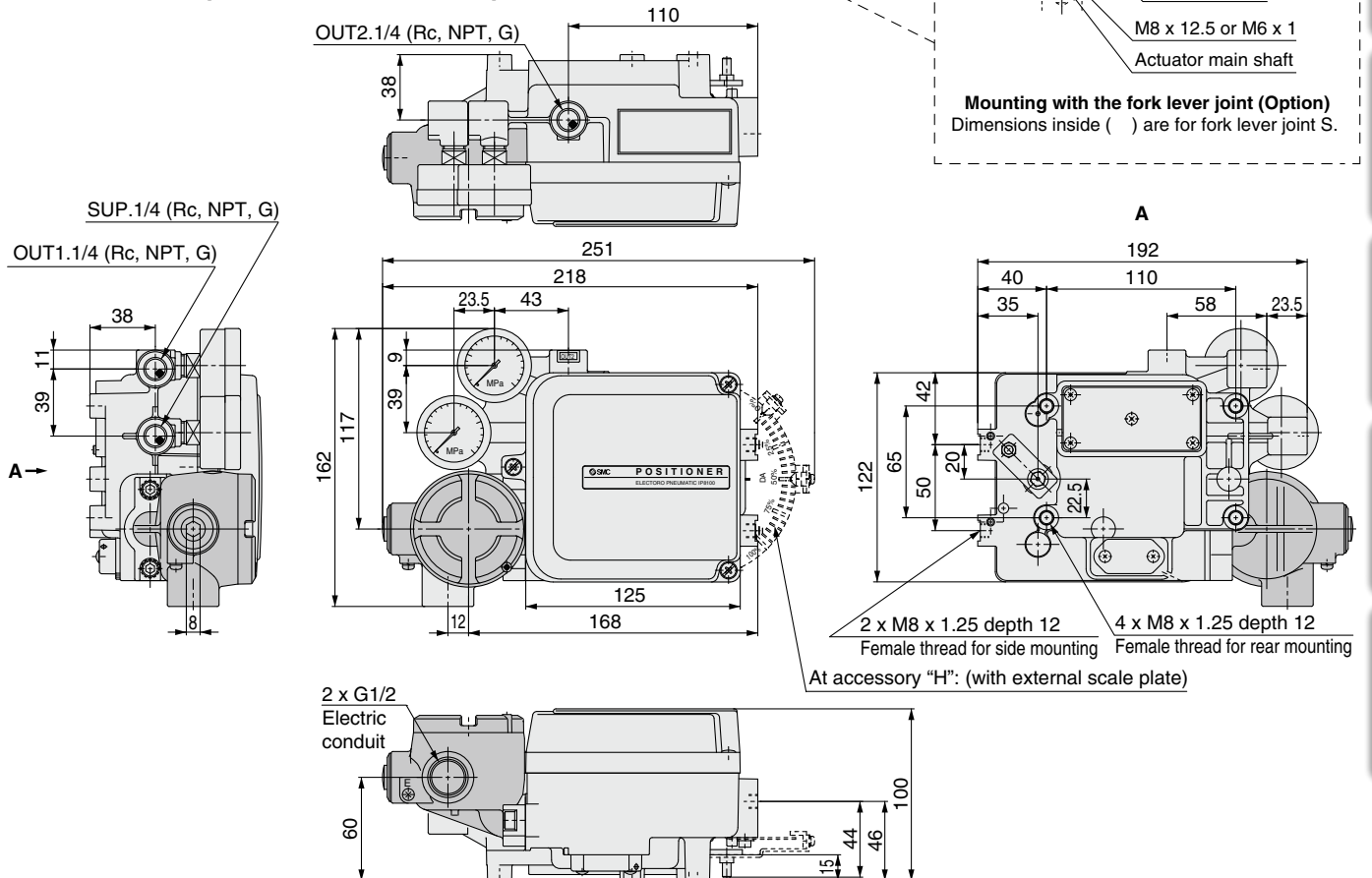



## Dimensions/IP8001 (Lever type)

IP8001- $\frac{0\Box}{0\Box3}$

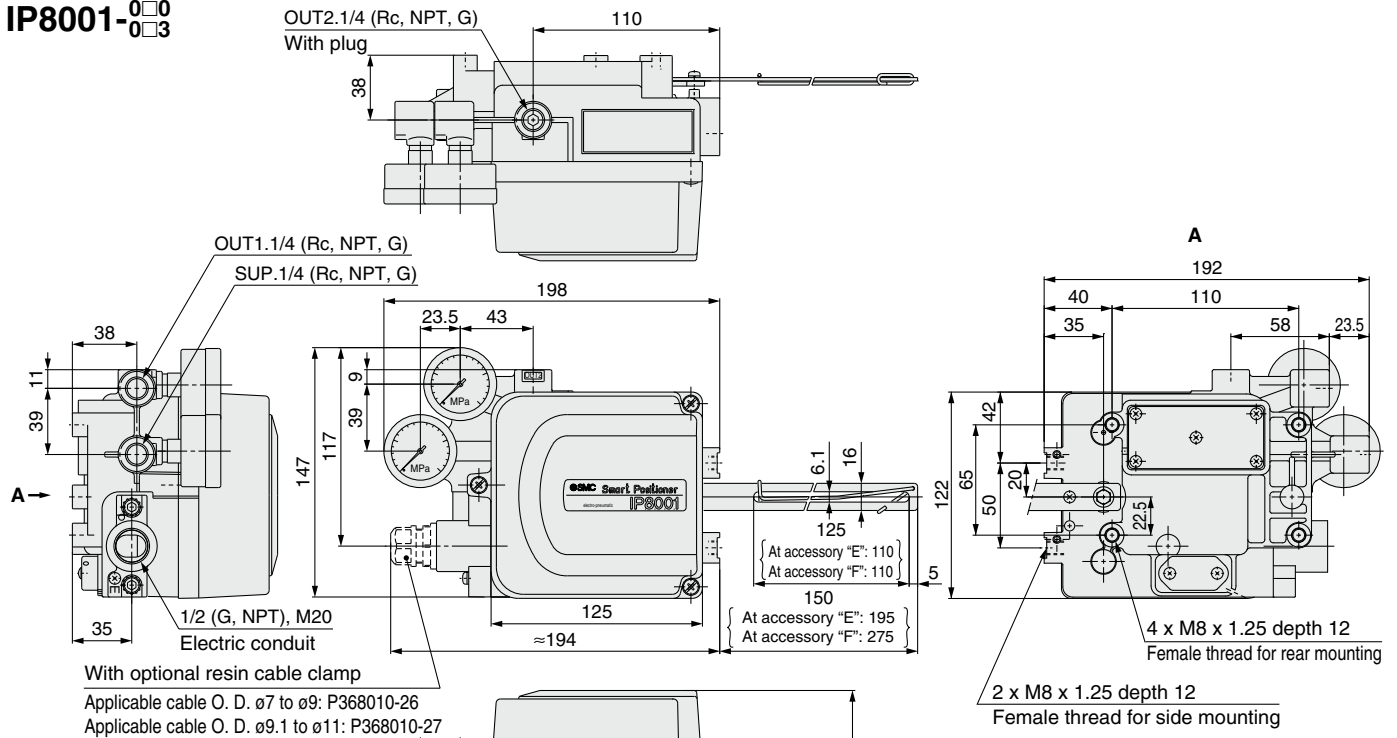

□-IP8001- $\frac{0\Box2}{0\Box4-W}$

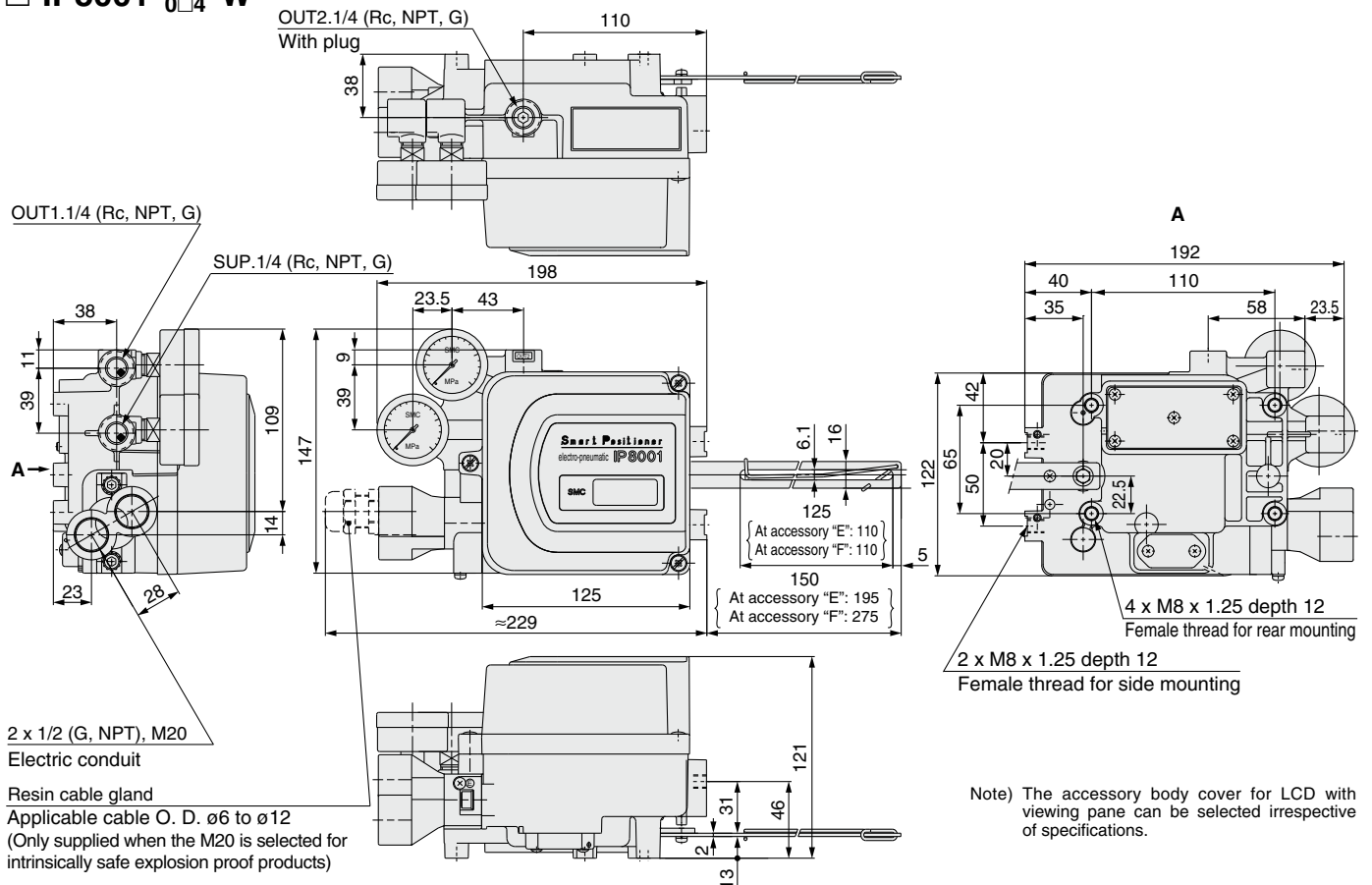

**Dimensions/IP8101 (Rotary type)**

**IP8101- $\frac{0}{0}$  $\frac{0}{3}$ -W**

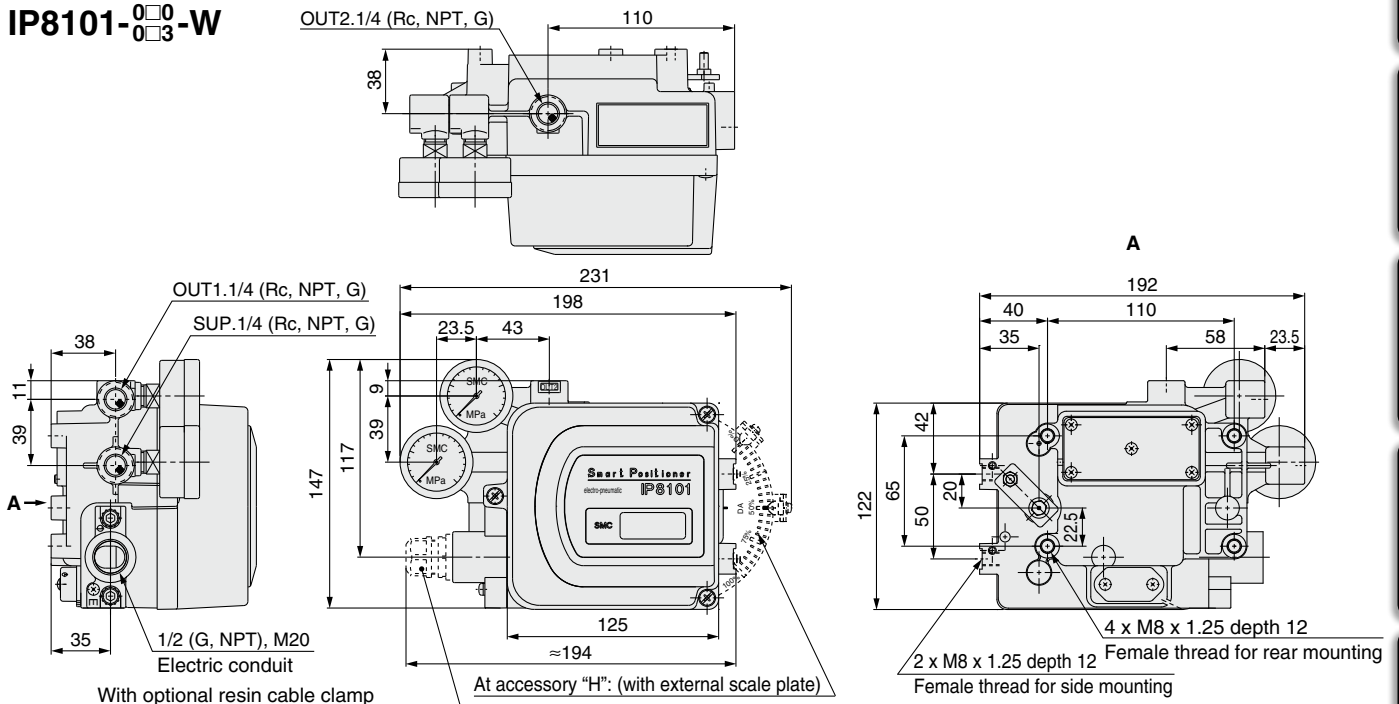

With optional resin cable clamp  
Applicable cable O. D.  $\phi 7$  to  $\phi 9$ : P368010-26  
Applicable cable O. D.  $\phi 9.1$  to  $\phi 11$ : P368010-27

**□-IP8101- $\frac{0}{0}$  $\frac{2}{4}$**

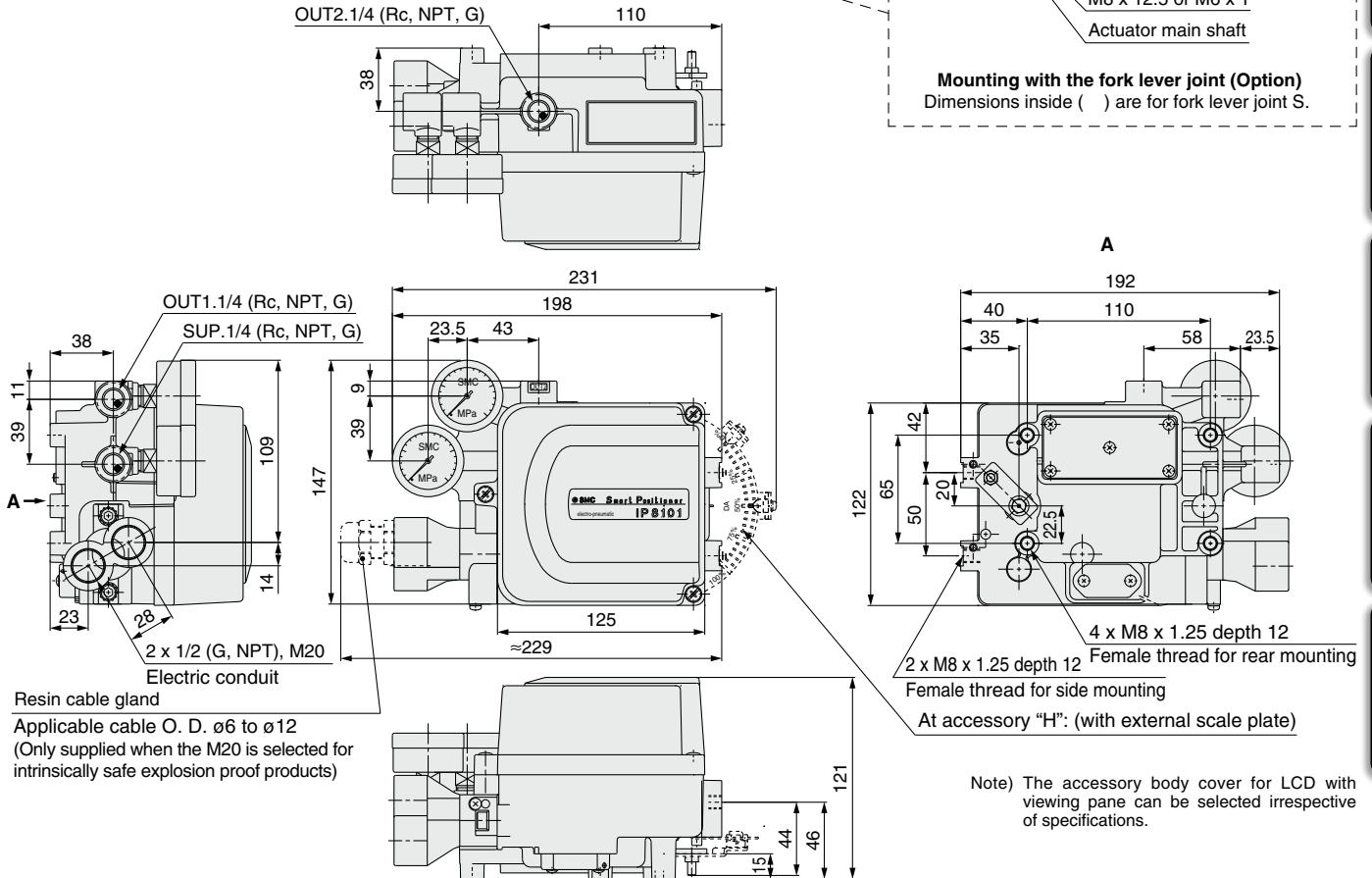

Note) The accessory body cover for LCD with viewing pane can be selected irrespective of specifications.

# Electro-Pneumatic Positioner (Lever type/Rotary type) Made to Order



Please contact SMC for detailed dimensions, specifications, and lead times.

## 1 Exterior Covering Enclosure: JISF8007 IP66 (Conforms to IEC60529)

\* Same as the standard, other than the IP66 compliant protective cover.

### How to Order

#### IP8000/Lever type

**IP8000-0**   -  -  - **X310** - **P** -

Lever type
● Pressure gauge (SUP, OUT1)
● Construction
● Accessories
● Connection<sup>Note 2)</sup>
● CE marking

Pressure gauge (SUP, OUT1)		Construction	Accessories	Connection <sup>Note 2)</sup>		CE marking			
Code	Pressure			Air	Electric	Code	Marking		
0	None	0 No terminal box (With non-explosive proof connector)	Nil	None (With standard lever)	Nil	Rc1/4	G1/2	Q	CE marked product
1	0.2 MPa		A	∅0.7 Output restriction with pilot valve	Nil	Rc1/4	G1/2		
2	0.3 MPa	1 With terminal box (Exd II BT5)	B	∅1.0 Output restriction with pilot valve	M	Rc1/4	M20 x 1.5	Q	CE marked product
3	1.0 MPa		E	For stroke 35 to 100 mm with lever unit (Standard lever is not attached.)	N	Rc1/4	1/2NPT		
			F	For stroke 50 to 140 mm with lever unit (Standard lever is not attached.)	1	1/4NPT	G1/2		
		G	Compensation spring (A) (It is mounted to the body as a replacement of the standard compensation spring.)	2	1/4NPT	M20 x 1.5			
				3	1/4NPT	1/2NPT			
				4	G1/4	G1/2			
				5	G1/4	M20 x 1.5			
				6	G1/4	1/2NPT			

Note 1) If two or more accessories are required, the part numbers should be given in alphabetical order.  
 Note 2) If 1 is selected for Construction, M, N, 2, 3, 5, 6 cannot be selected for Connection.

#### IP8100/Rotary type

**IP8100-0**   -  -  - **X310** - **P** -

Rotary type
● Pressure gauge (SUP, OUT1)
● Construction
● Accessories
● Connection<sup>Note 2)</sup>
● CE marking

Pressure gauge (SUP, OUT1)		Construction	Accessories	Connection <sup>Note 2)</sup>		CE marking			
Code	Pressure			Air	Electric	Code	Marking		
0	None	0 No terminal box (With non-explosive proof connector)	Nil	None (With standard lever)	Nil	Rc1/4	G1/2	Q	CE marked product
1	0.2 MPa		A	∅0.7 Output restriction with pilot valve	Nil	Rc1/4	G1/2		
2	0.3 MPa	1 With terminal box (Exd II BT5)	B	∅1.0 Output restriction with pilot valve	M	Rc1/4	M20 x 1.5	Q	CE marked product
3	1.0 MPa		C	Fork lever assembly M	N	Rc1/4	1/2NPT		
			D	Fork lever assembly S	1	1/4NPT	G1/2		
		G	Compensation spring (A) (It is mounted to the body as a replacement of the standard compensation spring.)	2	1/4NPT	M20 x 1.5			
				3	1/4NPT	1/2NPT			
				4	G1/4	G1/2			
				5	G1/4	M20 x 1.5			
				6	G1/4	1/2NPT			
		J	With opening current transmission (4 to 20 mA DC, with terminal box, non-explosion proof)/Positive operation						
		JR	With opening current transmission (4 to 20 mA DC, with terminal box, non-explosion proof)/Reverse operation						

Note 1) If two or more accessories are required, the part numbers should be given in alphabetical order.  
 Note 2) Symbol J/JR is with terminal box, non-explosion proof specification. Select 1 for Construction.  
 Note 3) If 1 is selected for Construction, M, N, 2, 3, 5, 6 cannot be selected for Connection.

**Dimensions**

**P8000-X310-P**

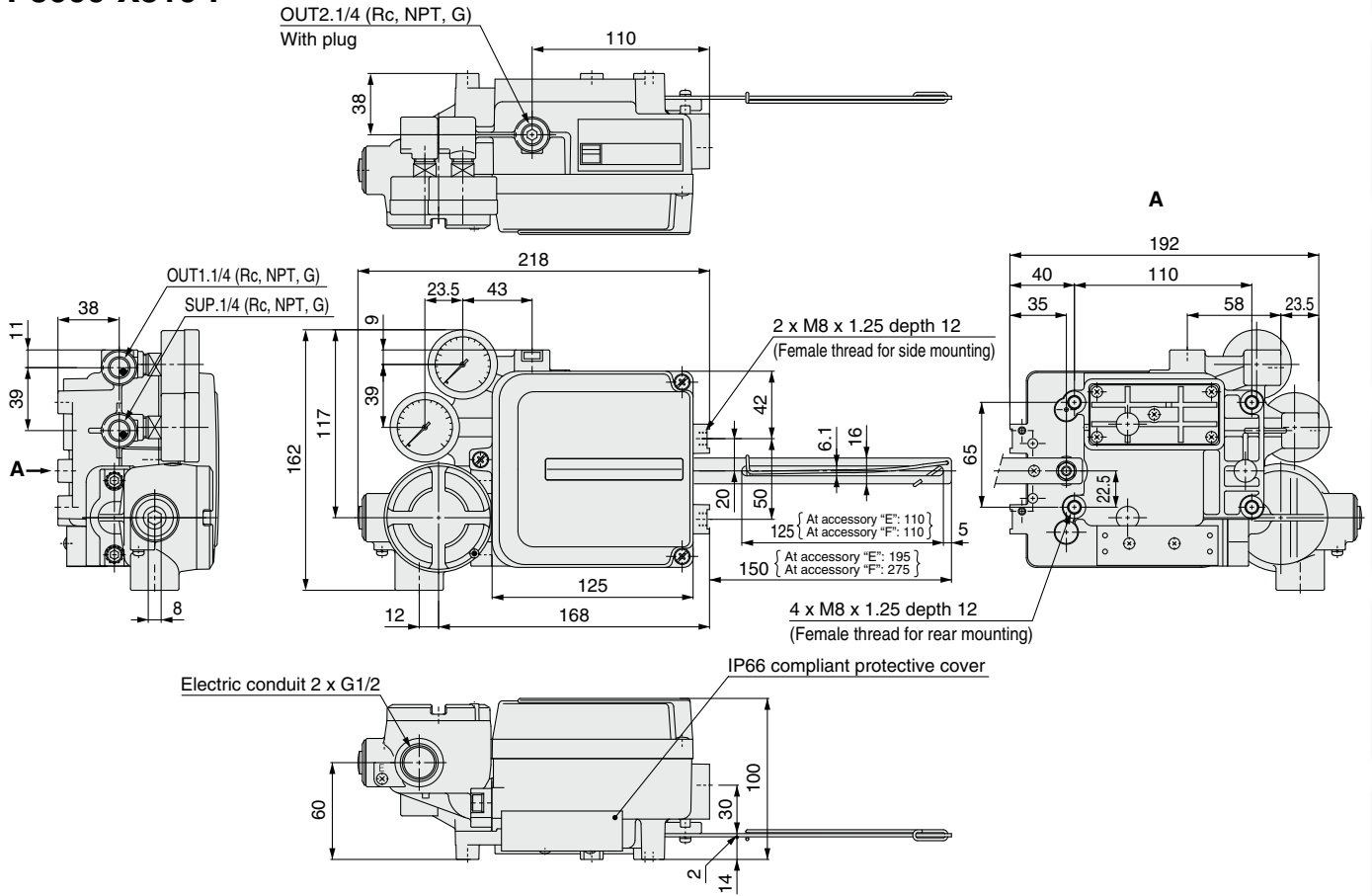

**IP8100-X310-P**

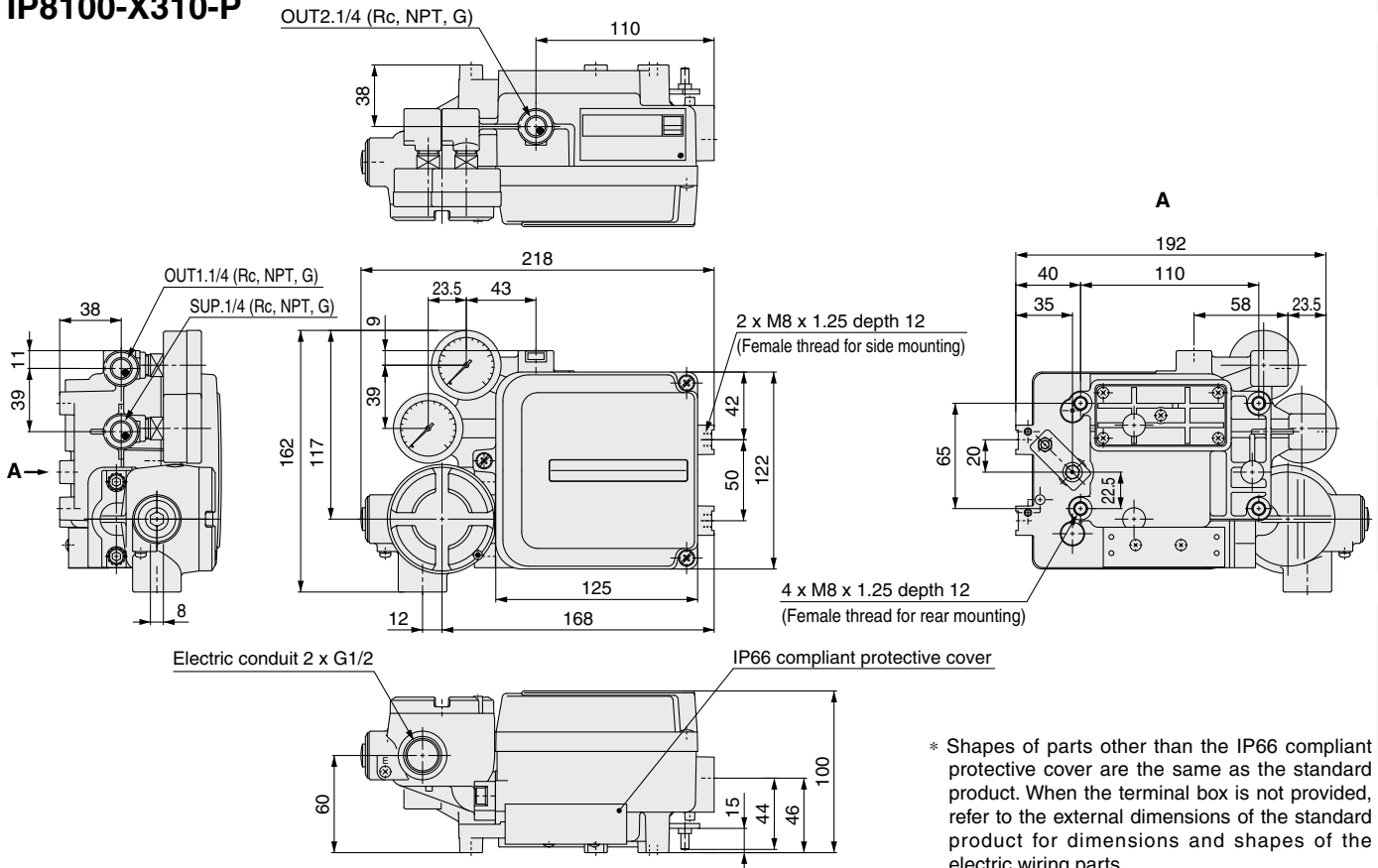

\* Shapes of parts other than the IP66 compliant protective cover are the same as the standard product. When the terminal box is not provided, refer to the external dimensions of the standard product for dimensions and shapes of the electric wiring parts.

- Positioners
- Regulators
- Relays/Valves
- Electro-Pneumatic Transducers
- Actuators
- Detection Conversion Unit
- Solenoid Valves
- Air Preparation Equipment
- Industrial Filters
- Piping Materials

## 2 Exterior Covering Enclosure: JISF8007 IP66 (Conforms to IEC60529)

\* Same as the standard, other than the IP66 compliant protective cover.

### How to Order

#### IP8001/Lever type

**ATEX directive compliance**  
 52 ATEX directive category 1

**Specifications**  
 4 Intrinsically safe explosion proof (ATEX) + Output function + HART transmission

**ATEX temperature**  

Nil	T4
T6	T5/T6

**52 - IP8001 - 0**  **4** -  -  -  - **X405 - P**  
**IP8001 - 0**   -  -  - **X405 - P** -

**Smart lever type**

Pressure gauge	Specifications	Accessories	Connection	CE marking
1 0.2 MPa	0 Basic type	Nil None (With standard lever)	Nil Air Electric	Nil —
2 0.3 MPa	2 With output function {Analog (4 to 20 mA DC) output + Alarm output × 2}	E For stroke 35 to 100 mm with lever unit (Standard lever is not attached.)	M Rc1/4 M20 x 1.5	Q CE marked product
3 1.0 MPa	3 With HART transmission function	F For stroke 50 to 140 mm with lever unit (Standard lever is not attached.) W Body with LCD window	N Rc1/4 1/2NPT 1 1/4NPT G1/2 2 1/4NPT M20 x 1.5 3 1/4NPT 1/2NPT 4 G1/4 G1/2 5 G1/4 M20 x 1.5 6 G1/4 1/2NPT	

Note 1) If two or more accessories are required, the part numbers should be given in alphabetical order.  
 Note 2) If a connecting port is M20 × 1.5, a blue cable gland is included.

#### IP8101/Rotary type

**ATEX directive compliance**  
 52 ATEX directive category 1

**Specifications**  
 4 Intrinsically safe explosion proof (ATEX) + Output function + HART transmission

**ATEX temperature**  

Nil	T4
T6	T5/T6

**52 - IP8101 - 0 3**  **4** -  -  -  - **X405 - P**  
**IP8101 - 0 3**   -  -  - **X405 - P** -

**Smart rotary type**

Pressure gauge	Specifications	Accessories	Connection	CE marking
3 1.0 MPa	0 Basic type	Nil None (Standard)	Nil Air Electric	Nil —
	2 With output function {Analog (4 to 20 mA DC) output + Alarm output × 2}	C Fork lever-type fitting M D Fork lever-type fitting S H With external scale plate	M Rc1/4 M20 x 1.5 N Rc1/4 1/2NPT	Q CE marked product
	3 With HART transmission function	W Body with LCD window	1 1/4NPT G1/2 2 1/4NPT M20 x 1.5 3 1/4NPT 1/2NPT 4 G1/4 G1/2 5 G1/4 M20 x 1.5 6 G1/4 1/2NPT	

Note 1) If two or more accessories are required, the part numbers should be given in alphabetical order.  
 Note 2) If a connecting port is M20 × 1.5, a blue cable gland is included.

## Dimensions

### IP8001-X405-P

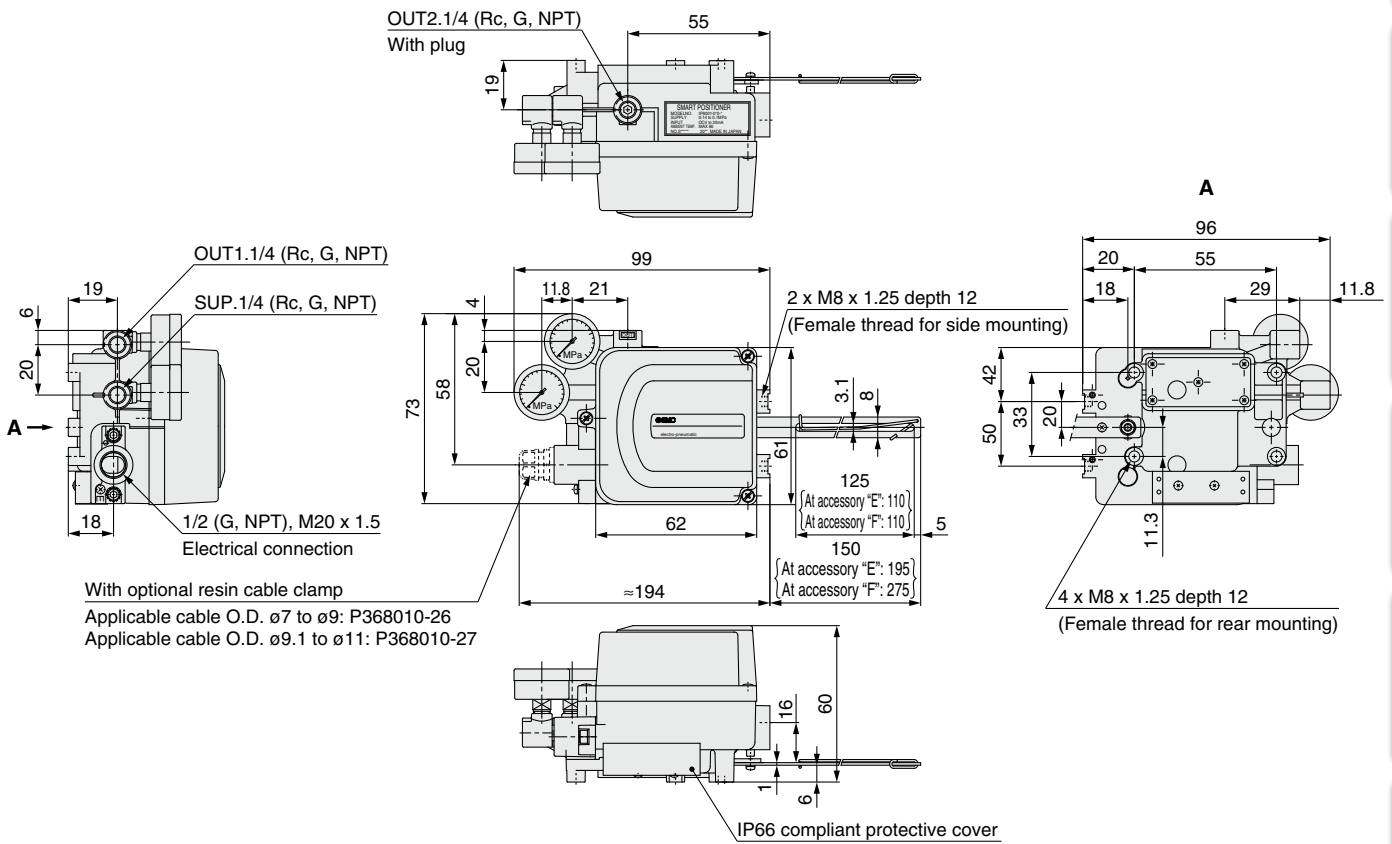

### IP8101-X405-P

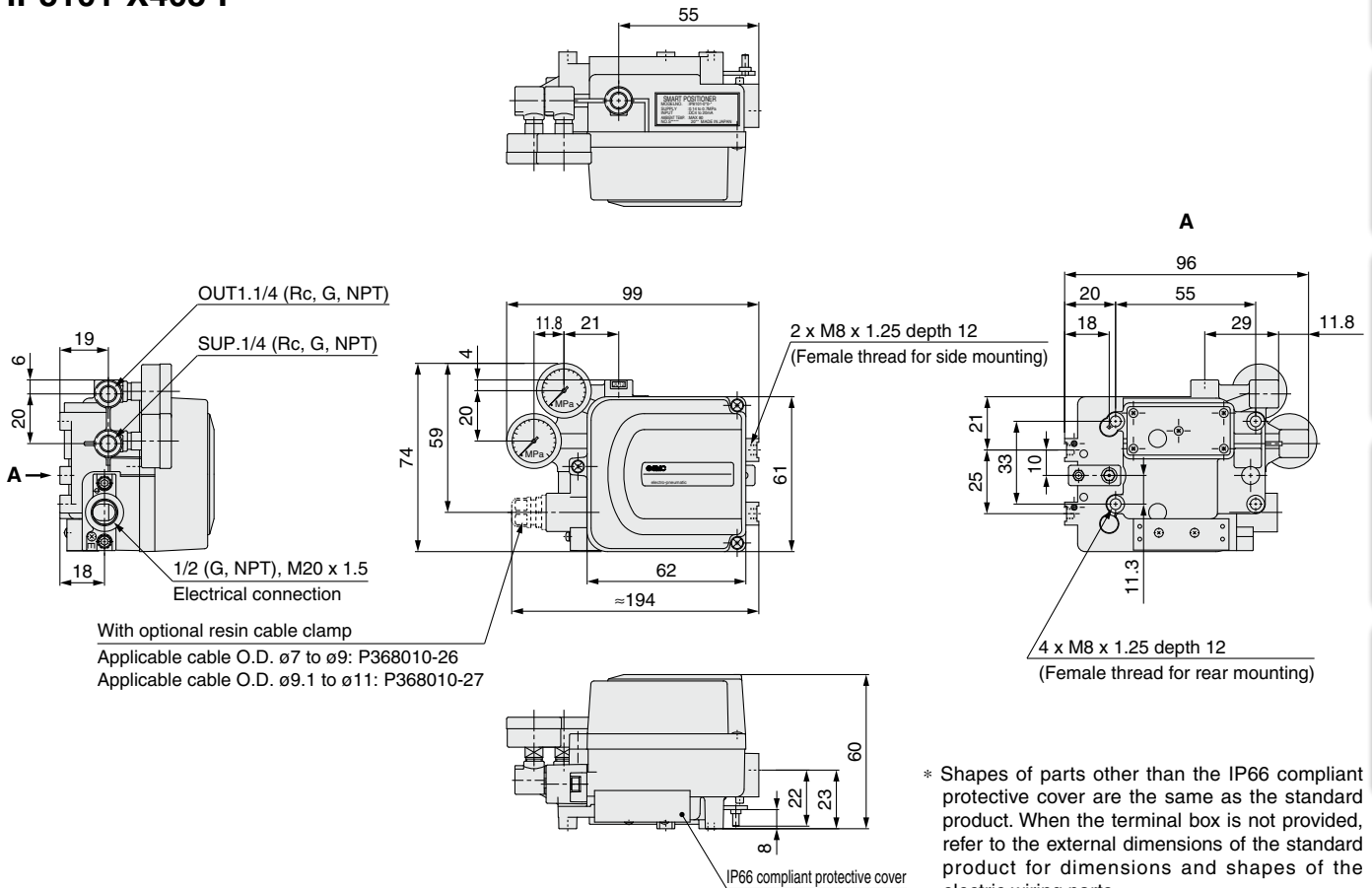

\* Shapes of parts other than the IP66 compliant protective cover are the same as the standard product. When the terminal box is not provided, refer to the external dimensions of the standard product for dimensions and shapes of the electric wiring parts.

# Technical data

## Explosion proof

### 1. TIIS explosion-proof construction

The electro-pneumatic positioner IP8000/8100 becomes explosion proof, as certified by TIIS, according to the model selected. The explosion-proof grade has the following approval: Exd II BT5.

Take extra care when handling the positioner as explosion-proof equipment

#### To use as Exd II BT5

##### A) Pressure-proof packing

As shown below in the chart, use "Cable gland" (Option).

##### B) Metal piping

Attach the sealant fitting bracket near the cable port.

(For details, refer to "The guideline on electric equipment explosion proof" published by the Technology Institution of Industrial Safety).

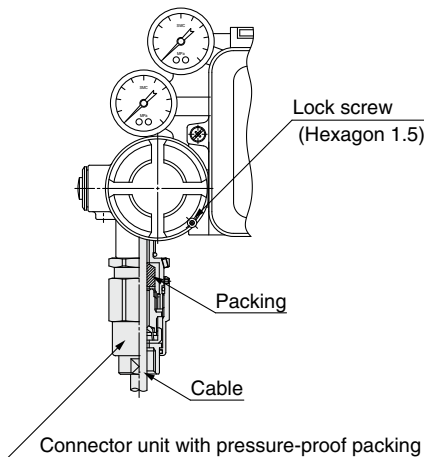

#### Cable gland with pressure proof packing (Option)

Description	Unit product no.	Applicable outside diameter
Connector unit with pressure proof packing	P368010-32	ø7.0 to ø10.0
	P368010-33	ø10.1 to ø12.0

### 2. ATEX Intrinsically safe explosion-proof construction

Pneumatic positioners IP8000/8100 and IP8001/8101 Smart Positioners are ATEX compliant, intrinsically safe and explosion proof, as certified by KEMA, the accreditation body for explosion-proof products. Take extra care when handling these explosion-proof products.

In regards to explosion-proof grades,

The Pneumatic Positioner IP8□00 meets II 2G Ex ib II CT5/T6, and

The Smart Positioner IP8□01 meets the II 1G Ex ia II CT4/T5/T6.

Check the positioner's specifications and explosion-proof grades and use in the most optimal environment.

#### • Wiring

When using the positioner as an intrinsically safe explosion-proof product, always set up a barrier in a **safe environment**, and perform each positioner's wiring through the barrier. Simultaneously, use the provided cable gland (M20 x 1.5) as the extension for the lead wire. If a connecting port other than M20 x 1.5 is selected, the cable gland will not be provided, so use a cable gland with the same or greater explosion-proof grades than this positioner.

#### • Barrier

Connect the barrier as shown in the diagram below. Moreover, the user must select a barrier that is suitable for each function, based on the ATEX intrinsically safe explosion-proof parameters (current circuit). For IP8001/8101 type smart positioners, use a linear resistant type barrier that is based on the explosion-proof parameters.

#### Barrier connection diagram

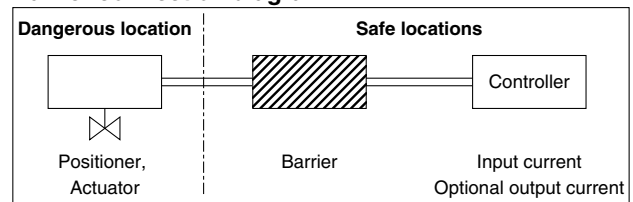

Moreover, at SMC, the barriers listed in the chart below are used to check operations. To purchase, please contact PEPPER + FUCHS Inc. (Germany).

#### Recommended barriers

	Manu- facturer	Model	Note	Applicable model	
				IP8□00-X14	52-IP8□01
For input signal (non HART transmission)	PEPPERL + FUCHS (Germany)	KFD2-CD-Ex1.32	—	○	○
For input signal (for HART transmission)		KFD2-SCD-Ex1.LK KCD2-SCD-Ex1	—	—	○
For analog output		KFD2-STC4-Ex1	—	—	○
For alarm output		KFD2-SOT2-Ex2	Transistor Output passive type	—	○
		KFD2-ST2-Ex2	Transistor Output passive type	—	○
		KFD2-SR2-Ex2.W	Relay output	—	○

## HART transmission

With smart positioners IP8001/8101, the user can operate the positioner using buttons and change parameter settings by viewing the LCD display (shown the right). Furthermore, depending on the model selected, the same button operation and parameter settings, and monitoring is possible from a remote location via HART transmission.

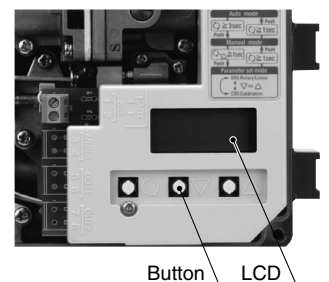

The table below lists an example of applications that are compatible with smart positioner IP8001/8101. Application selection must be made by the user. Please contact Emerson Process Management for further details.

#### HART transmission compatible application

Product name <sup>Note)</sup>	Manufacturer
AMS™ Suite : Intelligent Device Manager®	Emerson Process Management (US)
375 Field Communicator	

Note) AMS™ Suite: Intelligent Device Manager® is a registered trademark of Emerson Electric Co.



Series IP8 □

# Electro-Pneumatic Positioner/Smart Positioner Specific Product Precautions 1

Be sure to read this before handling.

## Operation

### ⚠ Warning

1. Do not operate the positioner outside the specified range as this may cause problems. (Refer to the specifications.)
2. Design the system to include a safety circuit to avoid the risk of danger should the positioner suffer failure.
3. Be sure that exterior lead-in wiring to the terminal box is based on the guidelines for explosion-protection of manufactory electric equipment when being used as a flame proof, explosion proof construction.
4. Do not remove terminal cover in a hazardous location while the power is on.
5. Covers for the terminal and body should be in place while operating.
6. When using as an intrinsically safe explosion-proof product, do not wire in a hazardous location while the power is on.

### ⚠ Caution

1. Do not touch the actuator or valve's oscillating section when supply pressure has been added, as this is dangerous.

2. Make sure fingers do not get caught when mounting and aligning the cam.

Cut off the pressure supply and always release the compressed air inside the positioner and actuator before performing this work.

3. Always use with the body cover unit mounted.

Moreover, the positioner may not meet degrees of protection IP65 depending on the body cover mounting conditions. In order to meet degrees of protection IP65, tighten threads using the proper tightening torques (2.8 to 3.0 N·m).

4. Always flush the pipe's insides before piping to ensure foreign objects such as machining chips do not enter the positioner.

5. The actuator opening may become unstable when using the booster relay.

6. Always use a ground connection to prevent noise from the input current and to prevent damage because of static electricity.

7. Use the pressure reading on the supplied pressure gauge as an indication.

8. The supplied pressure gauge's needle will malfunction if the pressure supply to the internal mechanism or positioner freezes.

Ensure that the pressure gauge's internal parts do not freeze if using the pressure gauge in an operating environment with an ambient temperature of less than 0°C.

9. This positioner performs the fixed position control.

Avoid turning ON or OFF the input signal highly frequently.

## For Users

### ⚠ Caution

1. Assemble, operate and maintain the positioners after reading the operation manual thoroughly and understanding the content.

## Handling

### ⚠ Caution

1. Avoid excessive vibration or impact to the positioner body and any excessive force to the armature, as these actions may cause damage to the product. Handle carefully while transporting and operating.

2. If being used in a place where vibration occurs, using a binding band is recommended to prevent broken wires because of the vibration.

3. When exposed to possible moisture invasion, please take the necessary measures. For example, if the positioner is left on-site for long periods, a plug should be put in the piping port and a body cover unit fitted to avoid water penetration.

Take measures to avoid dew condensation inside the positioner if exposed to high temperature and humidity. Take enough measures against condensation especially when packing for export.

4. Keep magnetic field off the positioner, as this affects its characteristics.

## Air Supply

### ⚠ Caution

1. As the positioner contains extra-fine orifices such as restrictor and nozzle, if drain or dust is present in the supply pressure line, malfunction (\*1) may result. In addition to an air filter (SMC Series AF), it is recommended to use a mist separator (SMC Series AM, AFM) and a micro mist separator (SMC Series AMD, AFD). Also, refer to "SMC Air Preparation System" for air quality.

2. Never use a lubricator, as this can cause a malfunction (\*1).

3. Do not use compressed air containing chemicals, organic solvents, salinity or corrosive gases, as this may cause malfunction.

4. When operating below the freezing point, protect the positioner from freezing.

\*1 If the restrictor is clogged, output from the OUT1 port of the positioner may occur continuously or hunching and overshoot may occur.

Positioners

Regulators

Relays/Valves

Electro-Pneumatic Transducers

Actuators

Detection Conversion Unit

Solenoid Valves

Air Preparation Equipment

Industrial Filters

Piping Materials





Series IP8□

# Electro-Pneumatic Positioner/Smart Positioner Specific Product Precautions 2

Be sure to read this before handling.

## Operating Environment

### ⚠ Caution

1. Do not operate in locations with an atmosphere of corrosive gases, chemicals, sea water, or where these substances will adhere to the regulator.
2. Do not operate out of the indicated operation temperature range as this may cause damage to electronic parts and seal materials to deteriorate.
3. Do not operate in locations where excessive vibration or impact occurs.
4. If the body cover is being installed in a place where the body cover is exposed to direct sunlight, the use of a standard body cover without the LCD window is recommended.

## Maintenance

### ⚠ Warning

1. After installation, repair or disassembly, connect compressed air and conduct tests to confirm appropriate function and leakage.

Do not use the positioner when noise from the bleeder sounds louder compared with the initial state, or when it does not operate normally. If these occur, check immediately if assembled and mounted correctly.

Never modify electrical construction to maintain explosion-proof construction.

### ⚠ Caution

1. Confirm whether the compressed air is clean.  
Dust, oil, or moisture mixed within the equipment may result in malfunction and positioner problems. Perform periodic inspection of the air preparation equipment to ensure clean air is always supplied.
2. Improper handling of compressed air is dangerous. Not only observing the product specifications, but also replacement of elements and other maintenance activities should be conducted by personnel having sufficient knowledge and experience pertaining to instrumentation equipment.
3. Perform annual inspections of the positioner.  
Replace badly damaged seals and units such as diaphragm and O-ring during the inspection.  
When used in tough environmental and/or service conditions such as seaside locations, replacements should be undertaken more frequently.

## Maintenance

### ⚠ Caution

4. When performing inspections, demounting the positioner, or replacing the elements with the positioner still in its mounted position, first, stop the compressed air, then exhaust the residual pressure before undertaking operation.
5. Should the restrictor become clogged with carbon particles, etc., demount automatic/manual change-over screw (with built-in restrictor) and clean it using a  $\varnothing 0.2$  wire.  
Stop the compressed air and remove the screw to switch the pilot valve off before replacing the restrictor.
6. Apply just a small amount of grease set by SMC to the sliding parts (O-ring and exhaust valve) when disassembling a pilot valve unit.  
Replacing the valve unit every three years is recommended.
7. Check for air leakage from pipes that pass compressed air and connecting parts.

Air leakage from air piping results in reduced operational performance and a decline of characteristics, etc.

It is structurally necessary for air to be released from the bleeder, it is not abnormal as long as the air consumption is within the specified range.