

1

리미트 스위치류 LIMIT SWITCHES



- 1-1 교류용 마이크로 스위치-Z형 (Alternating Current Micro Switch-Z Type)
- 1-2 직류용 마이크로 스위치-Z형 (Direct Current Micro Switch-Z Type)
- 1-3 소형 마이크로 스위치-V형 (Mini Micro Switch-V Type)
- 1-4 리미트 스위치 (Limit Switch)
- 1-5 소형 리미트 스위치 (Compact Limit Switch)

동작 특성에 관한 용어 | Terms for Operating Characteristics |

- 자유위치(F.P) : 외부에서 힘이 가해져 있지 않았을 때의 액추에이터의 위치
 - 동작위치(O.P) : 액추에이터에 외력이 가해져 가동접점이 자유위치 상태에서, 곧 반전할 때의 액추에이터 위치
 - 동작에 필요한 힘(O.F) : 자유위치로부터 동작위치까지 움직이게 하는데 필요한 액추에이터에 가해지는 힘
 - 동작까지의 움직임(P.T) : 액추에이터의 자유위치로부터 동작위치까지의 이동거리 또는 이동각도
 - 동작한도위치(T.T.P) : 액추에이터가 액추에이터 멈춤에 도달하였을때의 액추에이터의 위치
 - 동작후의 움직임(O.T) : 액추에이터의 동작위치로부터 동작한계위치까지의 이동거리 또는 이동각도
 - 되돌림 위치(R.P) : 액추에이터의 외력을 감소시켜, 가동접점이 동작위치의 상태에서 자유위치의 상태로 반전할 때의 액추에이터의 위치
 - 응차의 움직임(M.D) : 액추에이터의 동작위치에서부터 되돌림 위치까지의 이동거리 또는 이동각도
 - 전체의 움직임(T.T) : 액추에이터 자유위치에서 동작한도위치까지의 이동거리 또는 이동각도
 - 되돌림의 힘(R.F) : 동작한도 위치로부터 되돌림 위치까지 움직이는데 필요한 액추에이터에 가해진 힘
- Free Position(F.P) : Actuator's position when no external force is given.
 - Operating Position(O.P) : Actuator's position when the operating contact turns over soon by giving outer force to actuator in position state.
 - Operating Force(O.F) : Given force to actuator required to move from free position to operating one.
 - Pre Travel(P.T) : Moving distance or moving angle from actuator's free position to operating one.
 - Total Travel Position(T.T.P) : Actuator's position when actuator reaches at actuator stop position.
 - Over Travel(O.T) : Moving distance or moving angle from actuator's operating position to operating limit.
 - Release Position(R.P) : Actuator's position when operating contact turns over from operating position to free position with reducing actuator's outer force.
 - Movement Differential(M.D) : Moving distance or angle from actuator's operating position to release position.
 - Total Travel(T.T) : Moving distance or angle from actuator's free position to T.T.P(Operating limited one).
 - Release Force(R.F) : Given force to actuator required to move it from T.T.P to R.P.

동작 특성도 | Operating Characteristic Diagram |

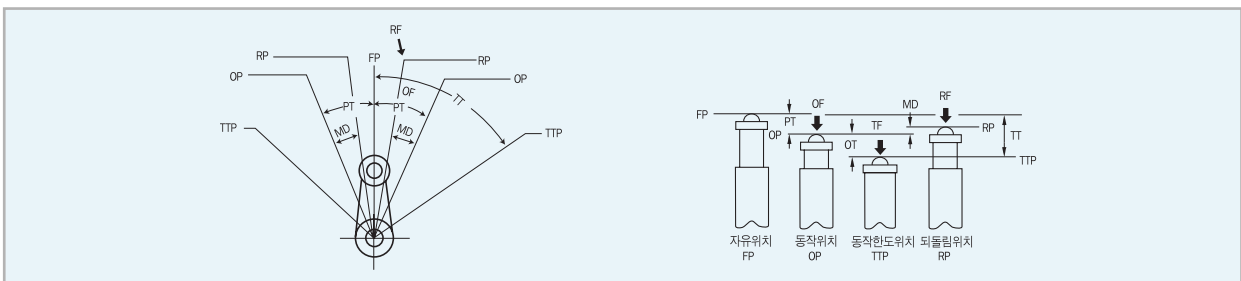

1-1

교류용 마이크로 스위치 (Z형)
Alternating Current Micro Switch (Z Type)

형식 구분도 | Type Classification Diagram |

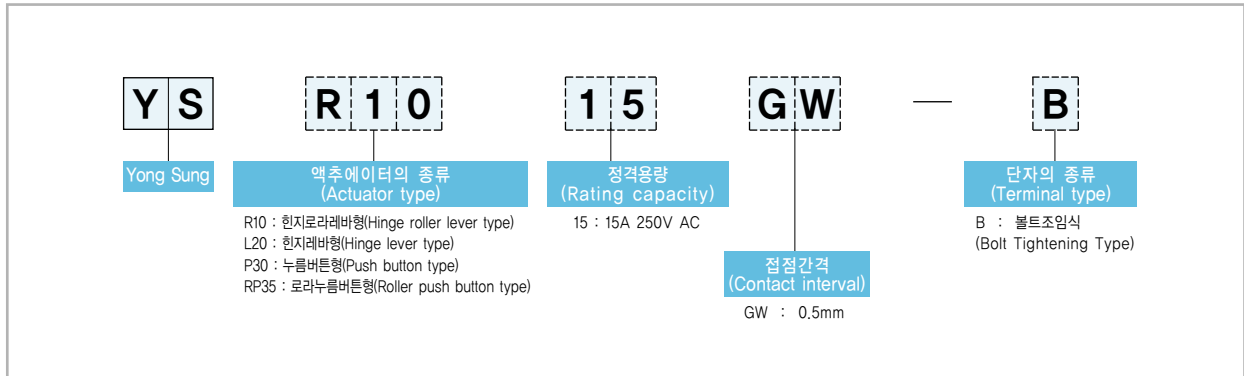

특징 | Features |

- 고신뢰성 마이크로 스위치
- AC 250V 15A의 개폐용량
- 고성능용으로 적합
- 액추에이터에는 누름버튼형과 힌지레버형 등의 다양한 종류가 있습니다.
- 내열, 내연 및 내아크성이 양호하므로 전기절연이 우수합니다.
- High-Reliability micro switch
- AC 250V 15A switching capacity
- Suitable for high performance use
- Various kinds of actuator such as push button type, hinge lever type etc.
- Excellent electric insulation due to good tendency of heat-resistant, smoke-resistant and arc-resistant.

내부 구조도 | Inside Structure Diagram |

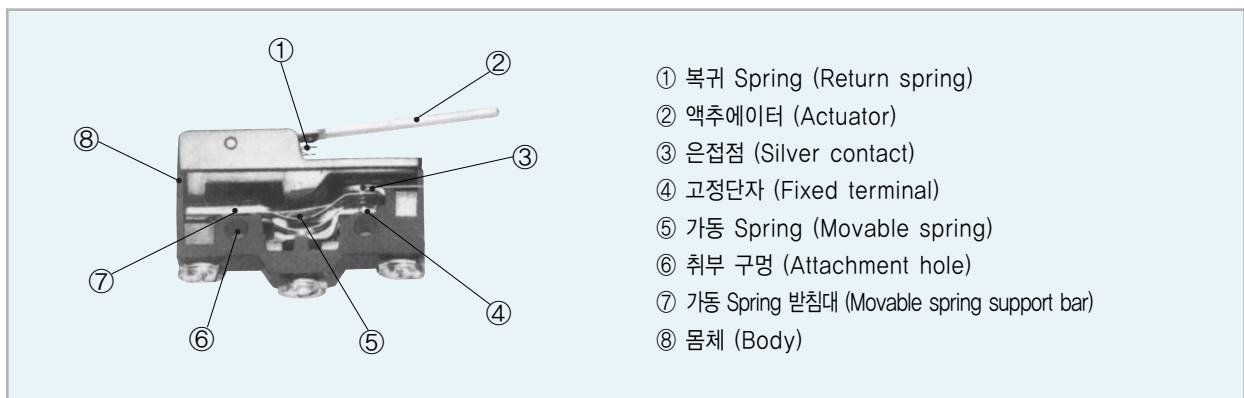

용도 | Application |

- 각종산업기계, 압력, 온도, 액면, 중량, 시간 등의 제어용 및 자동제어기에 사용됩니다.
- Used for control of various kinds of industrial machines, pressure, temperature, liquid face, weight, speed, time etc., and for automatic control devices.

접점 구성도 | Contact Form Diagram |

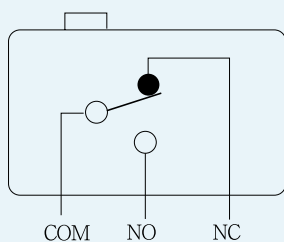

DC용 com (+) (DC type com (+))

수명 곡선 | Lifetime Curve |

• 기계적 수명곡선
(Mechanical lifetime curve)

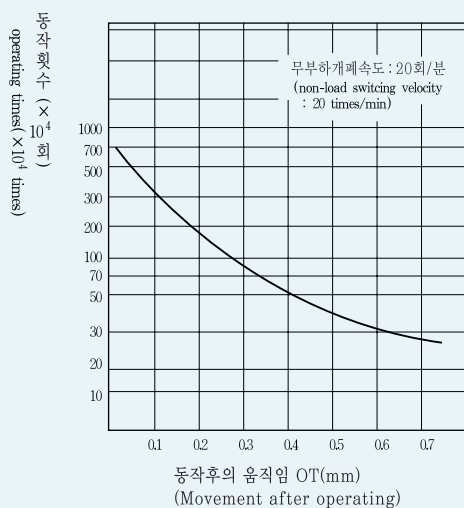

• 전기적 수명곡선
(Electrical lifetime curve)

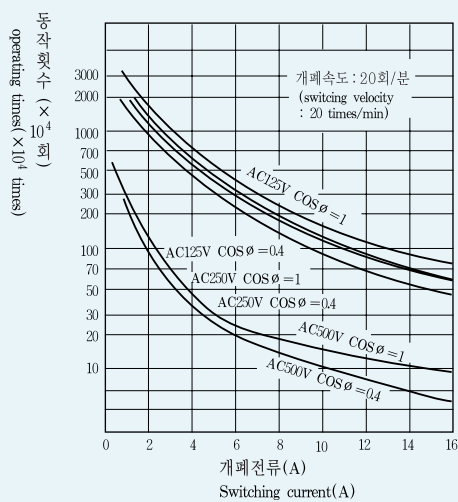

액추에이터의 종류 | Actuator Type |

분류명 (Classified type)	형상 (Shape)	특성 및 적용 (Characteristics & Application)		형식구분 (Designation)
단 누름버튼형 (Short push button)		버튼길이가 짧고 직경이 넓어 작동이 편함 (Easy operating by short button and wide dia.)		YS P3015GW-B YS P3010GW-B
장 누름버튼형 (Long push button)		저속CAM과 함께 사용 가능 (OT, 최대) (Possible to use with low speed CAM (OT, Max.))		YS P3315GW-B YS P3310GW-B
로라 누름버튼형 (Roller push button)		장누름버튼형에 로라부착 (OT, 대) (Roller Attached to long push button type (OT, large))		YS RP3615GW-B YS RP3610GW-B
가로 로라 누름버튼형 (Horizontal roller push button)		로라누름버튼형과 특성은 같으나 로라방향만 틀림 (Same characteristic as Roller push button except roller direction)		YS RP3515GW-B YS RP3510GW-B
힌지 단 레바형 (Hinge short lever)		동작력, 수명 정확도를 고려한 선택가능 (Choice possible considering operating force, life accuracy)	레바길이 최소 (Lever length Min.)	YS L2015GW-B YS L2010GW-B
힌지 중 레바형 (Hinge medium lever)			저속CAM에 사용가능 (Possible using for low speed CAM)	YS L2115GW-B YS L2110GW-B
힌지 장 레바형 (Hinge long lever)			저속CAM에 사용가능 (Possible using for low speed CAM)	YS L2215GW-B YS L2210GW-B
힌지 특장 레바형 (Hinge super long lever)			레바길이 최대 (Lever length Max.)	YS L2315GW-B YS L2310GW-B
힌지 로라 단 레바형 (Hinge roller short lever)		고속회전, 단직선 운동에 적합 (Suitable for high speed revolution & short linear movement)		YS R1015GW-B YS R1010GW-B
힌지 로라 중 레바형 (Hinge roller medium lever)		고속CAM에 적합 (Suitable for high speed CAM)		YS R1115GW-B YS R1110GW-B
힌지 로라 장 레바형 (Hinge roller long lever)		레바길이 최대 (Lever length Max.)		YS R1215GW-B YS R1210GW-B

정격 | Rating |

정격전압(V) (Rating voltage(V))	무유도부하(A) (No-inductive load(A))				유도부하(A) (Inductive load(A))			
	저항부하(Resistance load)(cosØ=1)		램프부하 (Lamp load)		유도부하(Inductive load) (cosØ=0.4, L/R=7ms)		전동기부하 (Motor load)	
	상시폐로 (Normal close)	상시개로 (Normal open)	상시폐로 (Normal close)	상시개로 (Normal open)	상시폐로 (Normal close)	상시개로 (Normal open)	상시폐로 (Normal close)	상시개로 (Normal open)
AC 125	15		2	1	7		2.5	2
250	15		1	0.5	5		1.5	1
DC 8	15		2	1	7		3	1.5
14	15		2	1	7		3	1.5
30	2		2	1	1		1	0.5
125	0.4		0.4	0.4	0.03		0.03	0.03
250	0.2		0.2	0.2	0.02		0.02	0.02

단자의 종류 | Terminal Types |

표시명 (Marking)	영문 (English)	명칭 (Designation)
COM	Common	공통단자 (Common terminal)
N.O	Normal Open	Normal open circuit
N.C	Normal Close	Normal close circuit

볼트 조임식 단자 | Bolt Tightening Type Terminal |

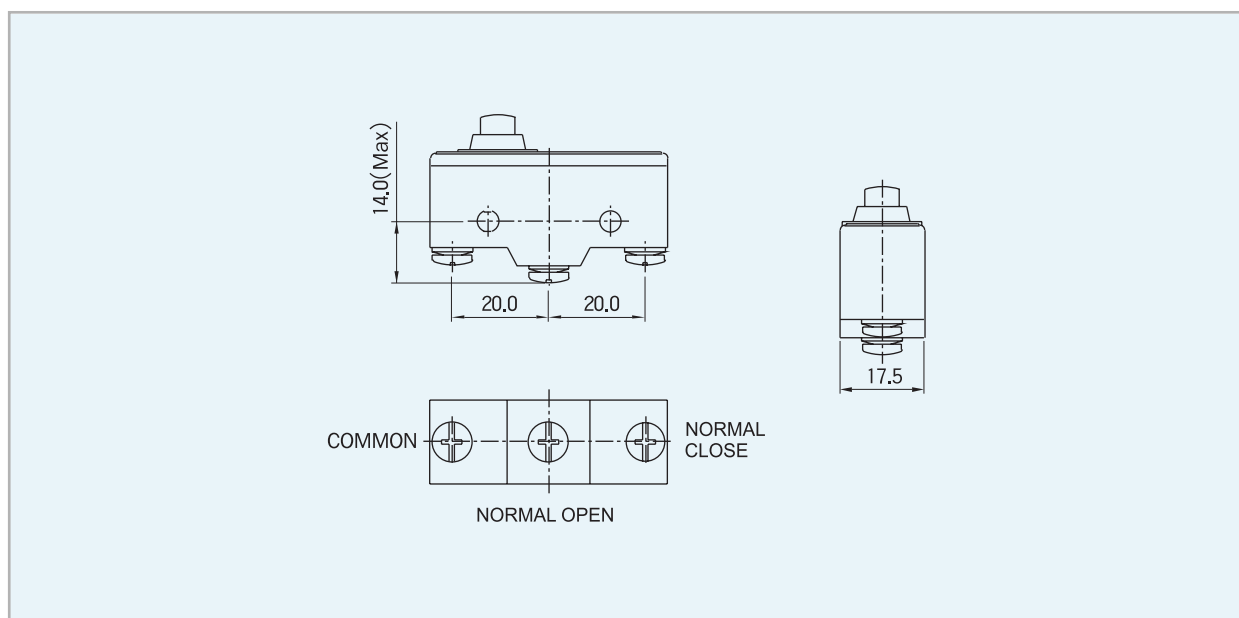

성능 개요 | Performance Summary |

개폐빈도 (Switching frequency)	기계적 (Mechanical)	20 times/min
	전기적 (Electrical)	20 times/min
절연저항 (Insulation resistance)		Above 100MΩ (DC 500V. Meg)
접촉저항 (Contact resistance)		Below 50mΩ (Initial value)
내진동 (Withstand vibration)		Double amplitude 1.5 mm (10~55Hz)
내충격 (Withstand impact)		300 ㎥ (About 30G)
내전압 (Withstand voltage)		AC 1,500V/min (50~60Hz)
수명 (Lifetime)	기계적 (Mechanical)	Above 1,000,000 times
	전기적 (Electrical)	Above 100,000 times
사용주위온도 (Ambient temperature)		-25℃~ +55℃
상대습도 (Relative humidity)		45 ~ 85%

형별 부품 재질 | Part Material Per Type |

형명 (Type) 부품 (Part)	YS R 힌지 로라 레바형 (Hinge roller lever type)	YS L 힌지 레바형 (Hinge lever type)	YS P 누름버튼형 (Push button type)	YS RP 로라 누름버튼형 (Roller push button type)
몸체 (Body)	열경화성 페놀 수지 (Thermosetting Phenol resin)			
액추에이터 (Actuator)	스테인레스강 (Stainless steel)		황동 + 니켈도금 (Brass + Ni도금)	
단자 (Terminal)	황동 (Brass)			
가동 스프링 (Movable spring)	베릴륨동 (Beryllium copper)			
접점 (Contact)	은 (Silver)			
부싱 (Bushing)	-		황동 (Brass)	

재질 특성 | Material Features |

- 열경화성 페놀수지 : 내열성, 내충격성, 내절연성, 내식성 양호
- Stainless 강 : 내식성, 휨강도, 내마모성, 내열성 양호
- 황동 : 전도성 양호
- 베릴륨동 : 전도성, 내식성, 복귀능력 양호
- 은접점 : 산화방지, 내마모성, 내아크성, 낮은 접촉저항, 낮은온도 상승, 긴 수명
- Thermosetting phenol resin : good of heat resistance, impact resistance insulation corrosion resistance
- Stainless steel : good of corrosion resistance, wear resistance, heat resistance and bending strength
- Brass : good of conductivity
- Beryllium copper : good of conductivity, corrosion resistance and return capability
- Silver : anti-oxidation, wear resistance, arc resistance, low contact resistance, low temperature increase, long life-time

외형 / 치수도 | Shape / Dimension Drawing

(unit : mm)

YS R1015GW-B

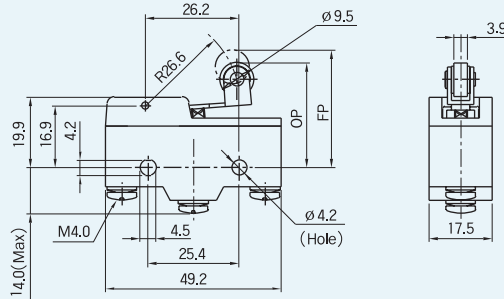

OF 최대(max.)	160gf
RF 최소(min.)	28gf
OT 최소(min.)	2.0mm
MD 최대(max.)	1.2mm
FP 최대(max.)	32.9mm
OP	30.2±1.0mm

YS R1115GW-B

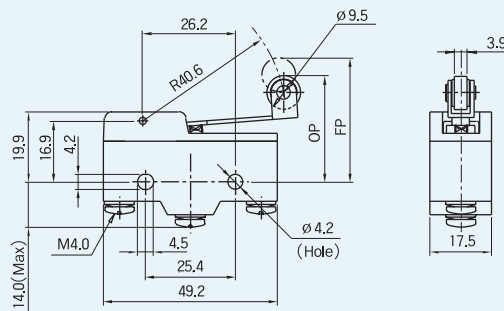

OF 최대(max.)	130gf
RF 최소(min.)	50gf
OT 최소(min.)	4.0mm
MD 최대(max.)	2.0mm
FP 최대(max.)	35.0mm
OP	28.0±0.8mm

YS R1215GW-B

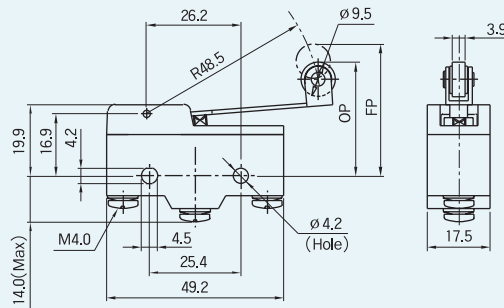

OF 최대(max.)	100gf
RF 최소(min.)	15gf
OT 최소(min.)	3.6mm
MD 최대(max.)	2.4mm
FP 최대(max.)	36.5mm
OP	30.2±1.0mm

YS L2015GW-B

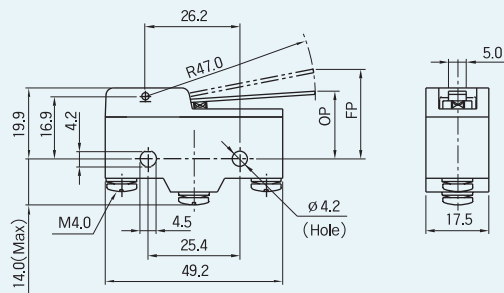

OF 최대(max.)	120gf
RF 최소(min.)	50gf
OT 최소(min.)	2.0mm
MD 최대(max.)	2.0mm
FP 최대(max.)	24.8mm
OP	17.0±0.8mm

YS L2115GW-B

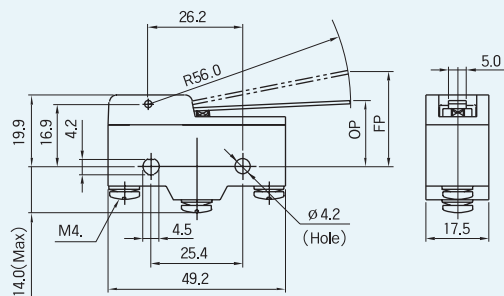

OF 최대(max.)	100gf
RF 최소(min.)	40gf
OT 최소(min.)	4.0mm
MD 최대(max.)	3.0mm
FP 최대(max.)	26.4mm
OP	18.4±0.8mm

외형 / 치수도 | Shape / Dimension Drawing |

(unit : mm)

YS L2215GW-B

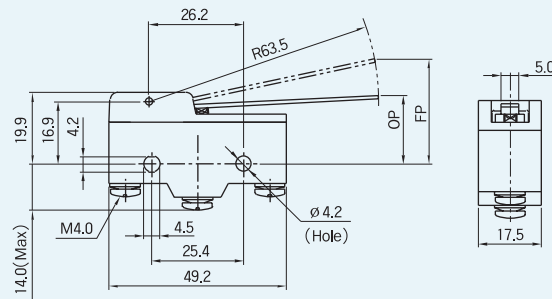

OF 최대(max.)	100gf
RF 최소(min.)	15gf
OT 최소(min.)	4.0mm
MD 최대(max.)	2.4mm
FP 최대(max.)	29.1mm
OP	19.1±1.0mm

YS L2315GW-B

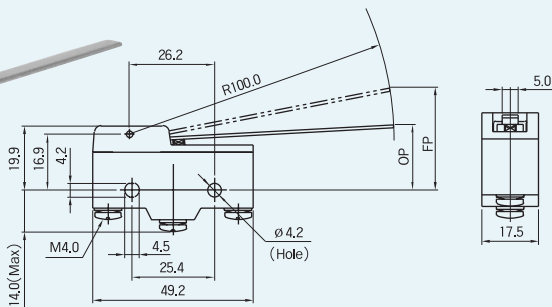

OF 최대(max.)	80gf
RF 최소(min.)	14gf
OT 최소(min.)	13mm
MD 최대(max.)	5mm
FP 최대(max.)	34.9mm
OP	29.9±1.2mm

YS P3015GW-B

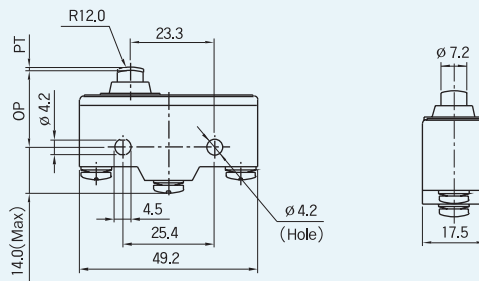

OF 최대(max.)	380gf
RF 최소(min.)	114gf
OT 최소(min.)	1.3mm
MD 최대(max.)	0.13mm
PT 최대(max.)	1.0mm
OP	21.2±0.8mm

YS P3315GW-B

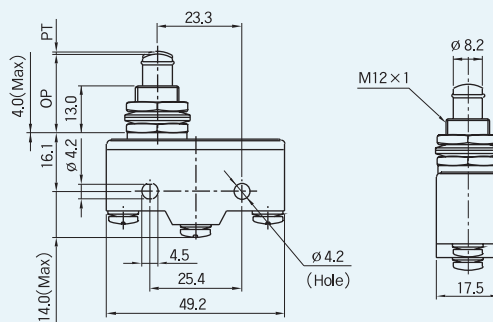

OF 최대(max.)	380gf
RF 최소(min.)	114gf
OT 최소(min.)	5.2mm
MD 최대(max.)	0.13mm
PT 최대(max.)	1.0mm
OP	21.8±0.8mm

YS RP3515GW-B

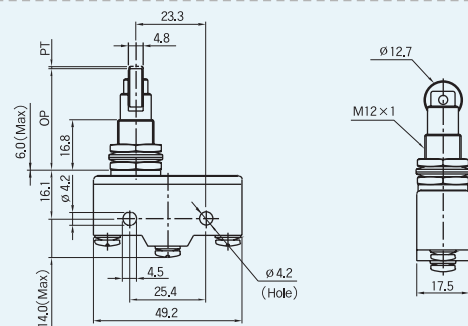

OF 최대(max.)	380gf
RF 최소(min.)	114gf
OT 최소(min.)	3.2mm
MD 최대(max.)	0.13mm
PT 최대(max.)	1.0mm
OP	33.4±1.4mm

외형 / 치수도 | Shape / Dimension Drawing |

(unit : mm)

YS RP3615GW-B

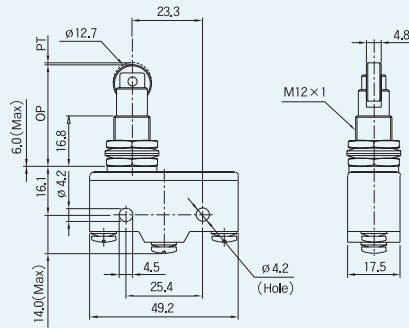

OF 최대(max.)	380gf
RF 최소(min.)	114gf
OT 최소(min.)	3.2mm
MD 최대(max.)	0.13mm
PT 최대(max.)	1.0mm
OP	33.4 ± 1.4mm

YS MS-C

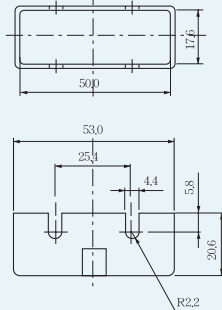
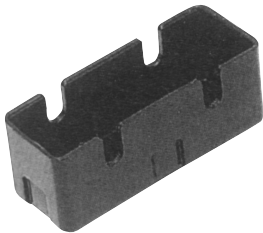

- 단자부 보호카바
- 본체 및 단자 접촉선 보호역할
- 단자간의 단락, 접지, 단선 등과 접속불량 및 감전사고 방지
- Protection cover between terminals
- Protection function for body and terminal contact wire
- Protection against short circuit between terminals grounding, short wire etc., and bad contact and electric shock

판넬 가공 치수 | Cut-out Dimension |

(unit : mm)

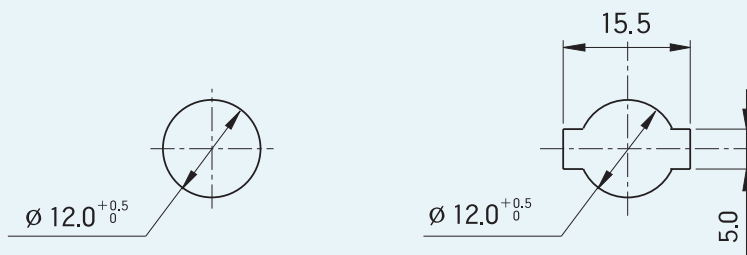

P3315

RP3515
RP3615

1-2

직류용 마이크로 스위치 (Z형)
Direct Current Micro Switch (Z Type)

형식 구분도 | Type Classification Diagram |

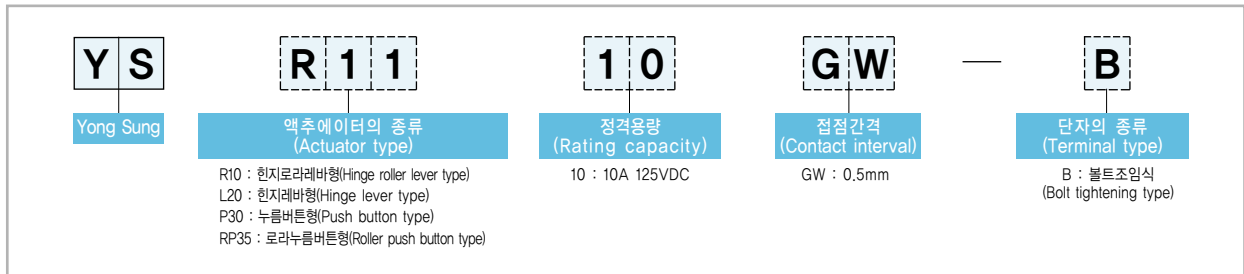

특징 | Features |

- 자기소거회로를 내장한 직류전용 마이크로 스위치입니다.
- 직류는 교류에 비해 아크 지속시간이 길기 때문에 접점기구에 아크의 효과적인 소거를 위한 영구자석을 내장시켰습니다.
- 아크에 의한 케이스 소손을 방지하기 위하여 케이스 내 격벽 및 접점간격을 넓혔습니다.
- 아크에 의해 발생된 가스를 배출키 위해 통기구멍을 설치하였습니다.
- * 공통단자에(COM) +극성을 연결해주시시오.
- It is a direct current micro switch built in with demagnetizing circuit.
- Permanent magnet is built in the switch to remove arc effectively from the contact parts.
- To protect the switch from arc, the distance between the partition walls and the distance between contacts are widen.
- An air vent is installed to expel the gas generated by arc.
- * Please connect the positive(+) pole to Common contact.

용도 | Application |

- 직류용 마이크로 스위치는 직류부하 개폐용으로 DC MOTOR나, 솔레노이드 등의 제어용으로 사용됩니다.
- 직류는 교류에 비해 아크(arc)발생이 크기 때문입니다.
- As a direct current switch, it is used to control DC Motor, Solenoid etc.
- Because direct current generates more arc than alternating current.

내부 구조도 | Inside Structure Diagram |

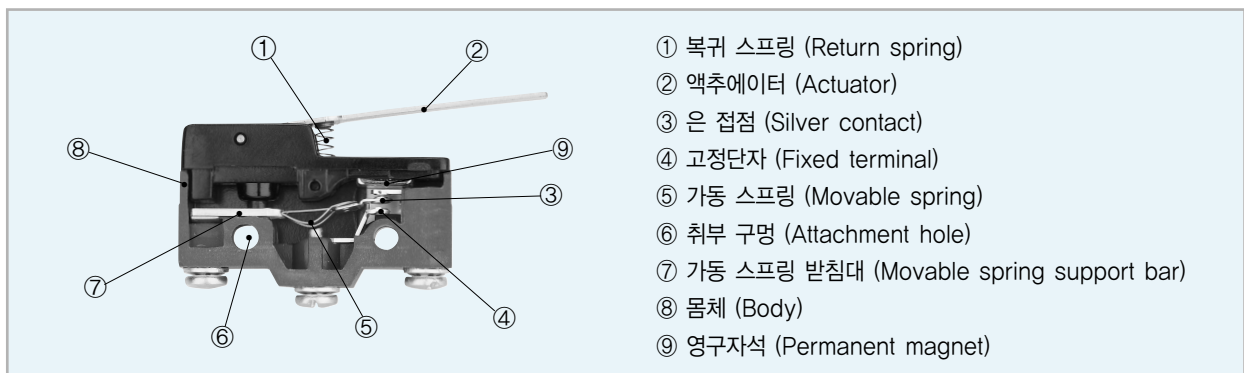

정격 | Rating |

정격전압(V) (Rating voltage(V))	무유도부하(A) (No-inductive load(A))				유도부하(A) (Inductive load(A))			
	저항부하 (Resistance load)(L/R=0)		램프부하 (Lamp load)		유도부하 (Inductive load) (L/R=7ms)		전동기부하 (Motor load)	
	상시폐로 (Normal close)	상시개로 (Normal open)	상시폐로 (Normal close)	상시개로 (Normal open)	상시폐로 (Normal close)	상시개로 (Normal open)	상시폐로 (Normal close)	상시개로 (Normal open)
DC 8	15		3	3	15	15	10	10
14	15		3	3	15	10	10	10
30	15		3	3	10	10	10	6
125	10		3	1.5	6	6	6	4
250	3		1.5	0.75	2	1.5	2	1

성능 개요 | Performance Summary |

허용조작속도 (Allowable operating speed)	0.1mm-1m/s	
개폐빈도 (Switching frequency)	기계적 (Mechanical)	20 times/min
	전기적 (Electrical)	20 times/min
절연저항 (Insulation resistance)	Above 100MΩ (DC 500V. Meg)	
접촉저항 (Contact resistance)	Below 50mΩ (Initial value)	
내전압 (Withstand voltage)	AC 1,500V/min (50~60Hz)	
내진동 (Withstand vibration)	오동작 (Malfunction)	Double amplitude 1.5 mm (10~55Hz)
내충격 (Withstand impact)	내구 (Endurance)	1,000 ٪ (About 100G)
	오동작 (Malfunction)	300 ٪ (About 30G)
수명 (Lifetime)	기계적 (Mechanical)	Above 1,000,000 times/min
	전기적 (Electrical)	Above 100,000 times/min
사용주위온도 (Ambient temperature)	-25°C ~ +55°C	
상대습도 (Relative humidity)	45 ~ 85%	

수명 곡선 | Lifetime Curve |

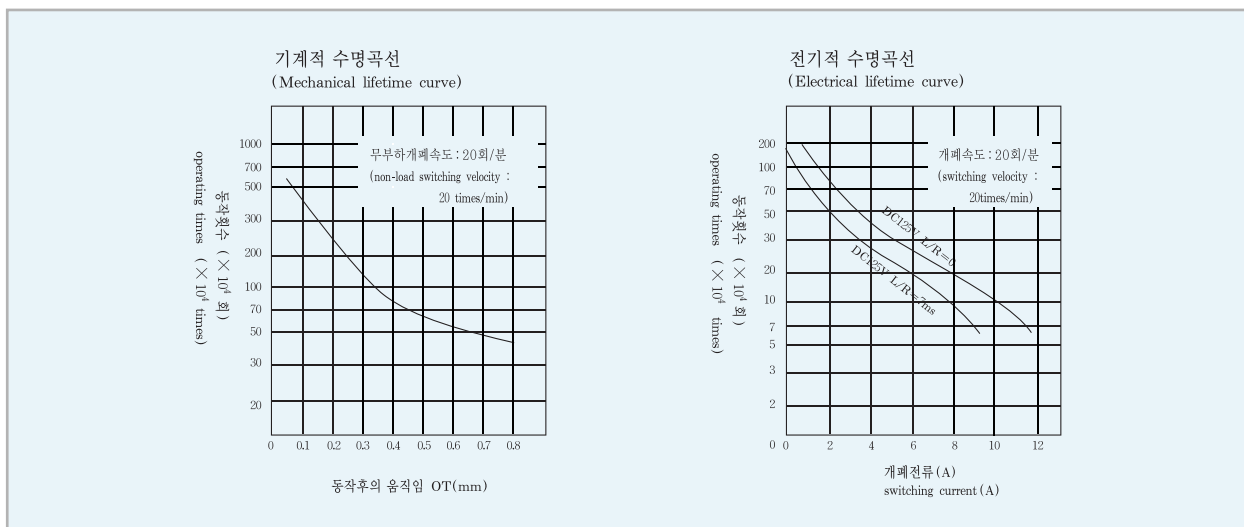

외형 / 치수도 | Shape / Dimension Drawing |

(unit : mm)

YS R1010GW-B

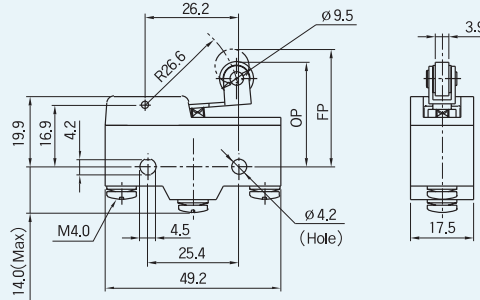

OF 최대(max.)	180gf
RF 최소(min.)	80gf
OT 최소(min.)	2.0mm
MD 최대(max.)	1.2mm
FP 최대(max.)	34.6mm
OP	29.4±1.0mm

YS R1110GW-B

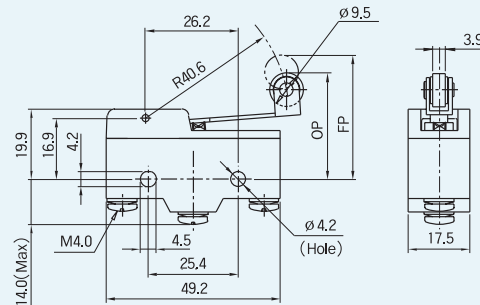

OF 최대(max.)	150gf
RF 최소(min.)	50gf
OT 최소(min.)	4.0mm
MD 최대(max.)	1.2mm
FP 최대(max.)	36.0mm
OP	30.0±1.0mm

YS R1210GW-B

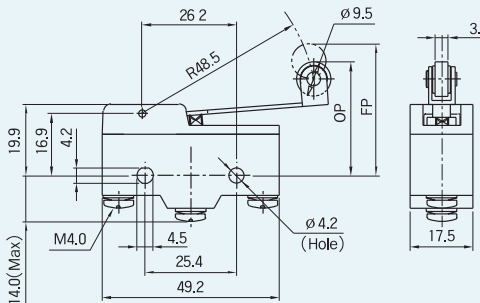

OF 최대(max.)	120gf
RF 최소(min.)	40gf
OT 최소(min.)	3.6mm
MD 최대(max.)	2.4mm
FP 최대(max.)	36.5mm
OP	30.2±1.0mm

외형 / 치수도 | Shape / Dimension Drawing |

(unit : mm)

YS L2010GW-B

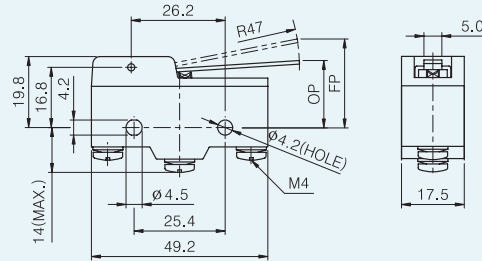

OF 최대(max.)	130gf
RF 최소(min.)	50gf
OT 최소(min.)	2.0mm
MD 최대(max.)	2.0mm
FP 최대(max.)	24.8mm
OP	18.8±0.8mm

YS L2110GW-B

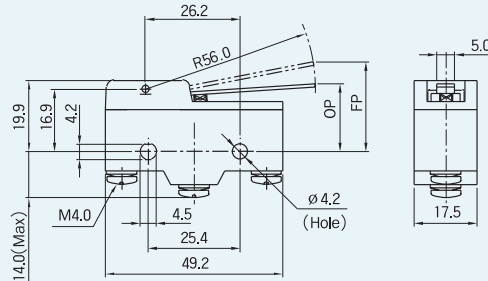

OF 최대(max.)	90gf
RF 최소(min.)	40gf
OT 최소(min.)	5.0mm
MD 최대(max.)	1.2mm
FP 최대(max.)	26.8mm
OP	18.4±0.8mm

YS L2210GW-B

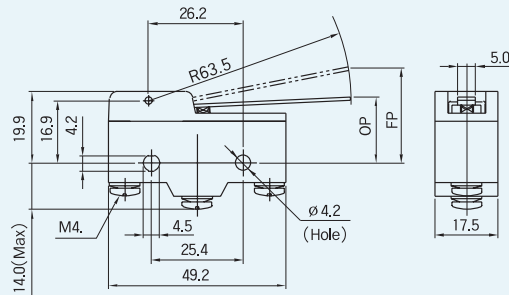

OF 최대(max.)	85gf
RF 최소(min.)	25gf
OT 최소(min.)	4.0mm
MD 최대(max.)	2.4mm
FP 최대(max.)	29.1mm
OP	19.1±0.8mm

YS L2310GW-B

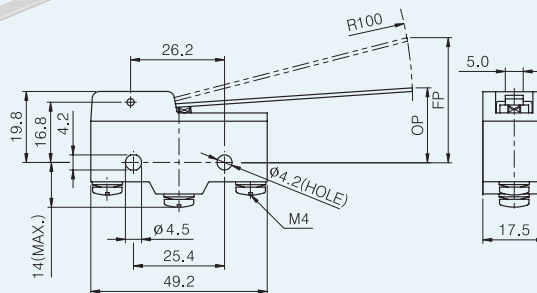
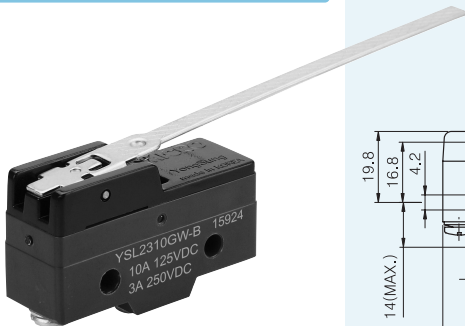

OF 최대(max.)	80gf
RF 최소(min.)	14gf
OT 최소(min.)	13mm
MD 최대(max.)	5.0mm
FP 최대(max.)	34.9mm
OP	20.9±1.2mm

외형 / 치수도 | Shape / Dimension Drawing |

(unit : mm)

YS P3010GW-B

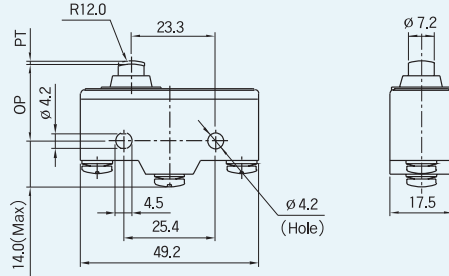

OF 최대(max.)	800gf
RF 최소(min.)	114gf
PT 최대(max.)	0.9mm
OT 최소(min.)	1.6mm
MD 최대(max.)	0.13mm
OP	21.2±0.5mm

YS P3310GW-B

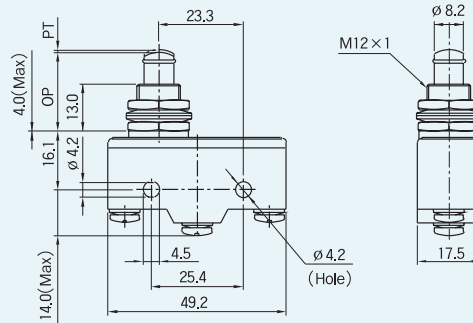

OF 최대(max.)	800gf
RF 최소(min.)	114gf
PT 최대(max.)	0.9mm
OT 최소(min.)	5.5mm
MD 최대(max.)	0.13mm
OP	21.8±0.8mm

YS RP3510GW-B

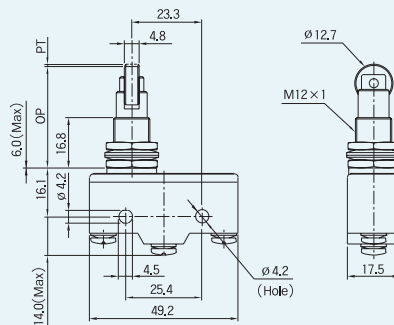

OF 최대(max.)	800gf
RF 최소(min.)	114gf
PT 최대(max.)	0.9mm
OT 최소(min.)	4.5mm
MD 최대(max.)	0.13mm
OP	33.4±1.2mm

YS RP3610GW-B

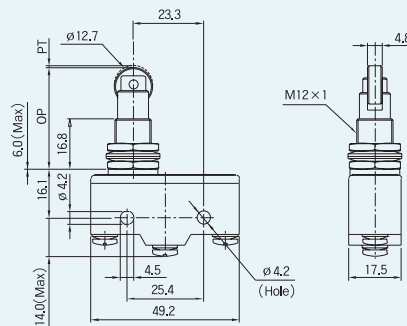

OF 최대(max.)	800gf
RF 최소(min.)	114gf
PT 최대(max.)	0.9mm
OT 최소(min.)	4.5mm
MD 최대(max.)	0.13mm
OP	33.4±1.2mm

1-3

소형 마이크로 스위치 (V형) Mini Micro Switch (V Type)



형식 구분도 | Type Classification Diagram

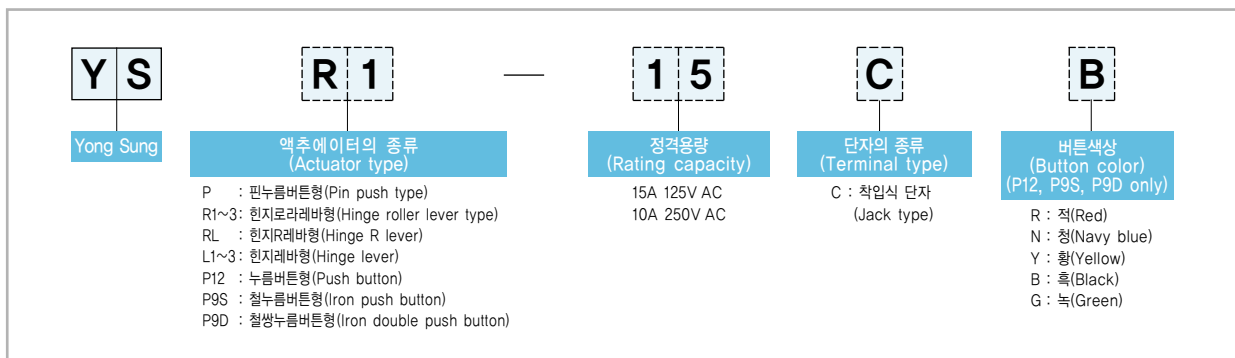

특징 | Features

- 정밀도가 높은 스위치로 고성능을 요구하는 용도에 적합함.
- 고용량 부하가 개폐되므로 산업용기계, 자동제어기기에 적합함.
- 종류에는 로라형, 레버형, 버튼형 등이 있어 용도별 선택이 가능함.
- High accuracy and suitable for high performance required.
- Due to switching of high capacity load, adequate for automatic control equipment and industrial equipment.
- Choice possible per application as roller lever, button type etc.

용도 | Application

- 전동공구, 공작기계, 민생용기기, 사무기, 통신, 측정기기 등 용도가 광범위함.
- Can be widely used for electric tools, machine tools, public purpose home equipment, office equipments, communication, measuring devices etc.

액추에이터의 종류 | Actuator Type

분류명 (Classification)	형상 (Shape)	형식구분 (Type classification)
핀누름버튼형 (Pin push button type)		YS P
힌지롤러레버형 (Hinge roller lever type)		YS R1, YS R2, YS R3
힌지R레버형 (Hinge R lever type)		YS RL
힌지레버형 (Hinge lever type)		YS L1, YS L2, YS L3
누름버튼형 (Push button type)		YS P12, YS P9S, YS P9D

내부 구조도 | Inside Structure Diagram |

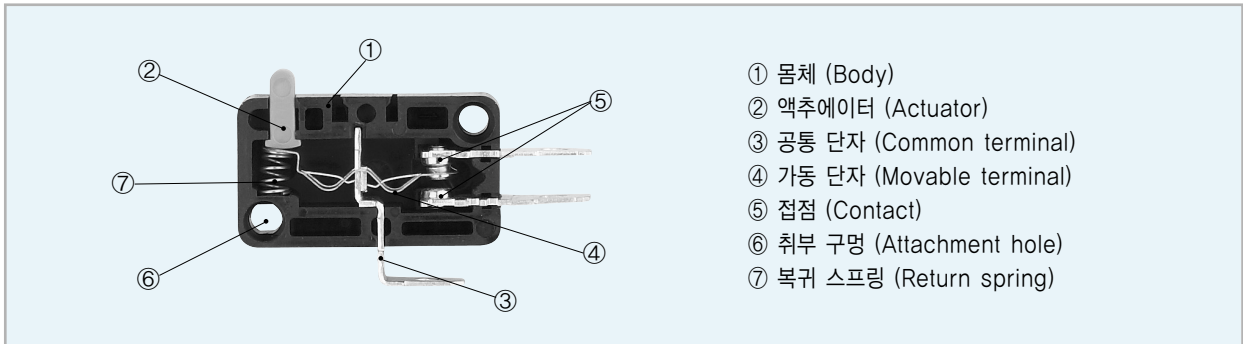

성능 개요 | Performance Summary |

허용조작속도 (Allowable operating speed)	0.1mm ~ 1m/s	
개폐빈도 (Switching frequency)	기계적 (Mechanical)	20 times/min
	전기적 (Electrical)	20 times/min
절연저항 (Insulation resistance)	Above 100MΩ (DC 500V. Meg)	
접촉저항 (Contact resistance)	Below 50mΩ (Initial value)	
내전압 (Withstand voltage)	AC 1,500V/min (50~60Hz)	
내진동 (Withstand vibration)	Double amplitude 1.5 mm (10~55Hz)	
내충격 (Withstand impact)	300 ٪ (About 30G)	
수명 (Lifetime)	기계적 (Mechanical)	Above 1,000,000 times
	전기적 (Electrical)	Above 100,000 times
사용주위온도 (Ambient temperature)	-25℃ ~ +55℃	
상대습도 (Relative humidity)	45 ~ 85%	

수명 곡선 | Lifetime Curve |

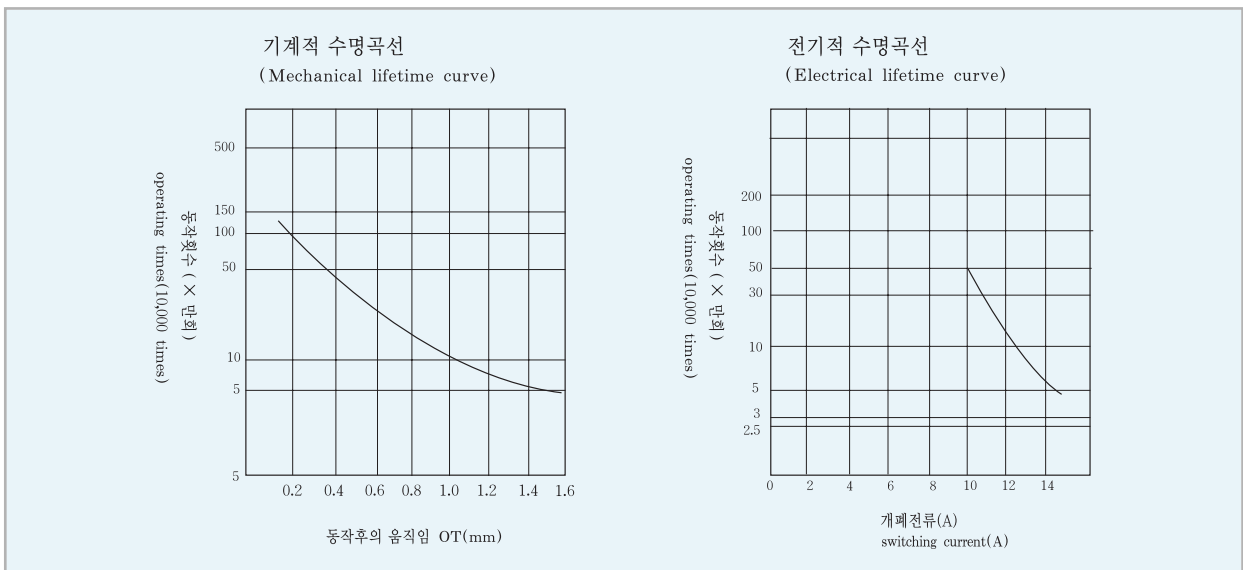

정격 | Rating |

정격전압(V) (Rating voltage(V))	무유도부하(A) (No-Inductive load(A))				유도부하(A) (Inductive Load(A))			
	저항부하 (Resistance load)(cosØ=1)		램프부하 (Lamp load)		유도부하 (Inductive load) (cosØ=0.4, L/R=7ms)		전동기부하 (Motor load)	
	상시폐로 (Normal close)	상시개로 (Normal open)	상시폐로 (Normal close)	상시개로 (Normal open)	상시폐로 (Normal close)	상시개로 (Normal open)	상시폐로 (Normal close)	상시개로 (Normal open)
AC 125	15		2		10		2	
250	10		1.5		6		2	
DC 8	10		3		6		3	
14	10		3		6		3	
30	6		3		4		3	
125	0.6		0.1		0.6		0.1	
250	0.3		0.05		0.3		0.05	

부품 재질 특성 | Part material Characteristics |

부품 (Part)	재질 (Materials)	특성 (Characteristics)
몸체 (Body)	PBT Resin	난연성, 내충격성, 내절연성, 내식성 양호 (Good of heat resistance, impact resistance insulation and corrosion resistance)
액추에이터 (Actuator)	Stainless 강 (Stainless steel)	내식성, 기계적 수명이 길다. (Corrosion resistance and long mechanical life time)
단자 (Terminal)	황동 (Brass)	전도성 양호 (Good of conductivity)
가동 단자 (Movable terminal)	베릴륨동 (Beryllium copper)	내식성, 복귀능력, 전도성 양호 (Good of corrosion resistance, resettability, conductivity)
접점 (Contact)	은 (Silver)	산화방지, 낮은 접촉저항, 내마모성, 내아크성 양호 (Good of anti-oxidation, low contact resistance, wear resistance & arc resistance)

외형 / 치수도 | Shape / Dimension Drawing |

(unit : mm)

YS P-15C

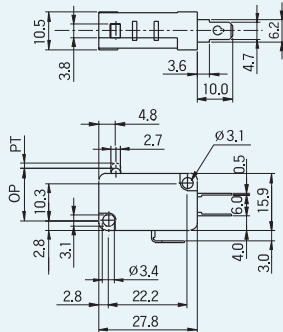
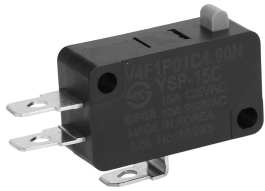

OF 최대(max.)	500gf
RF 최소(min.)	50gf
FP 최대(max.)	1.6mm
OT 최소(min.)	0.3mm
MD 최대(max.)	1.0mm
OP	14.7±0.7mm

YS R1-15C

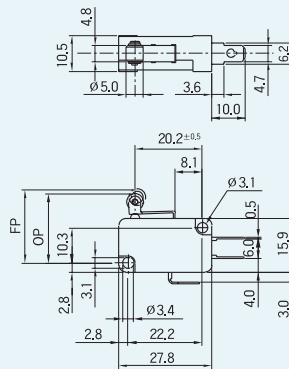

OF 최대(max.)	600gf
RF 최소(min.)	50gf
FP 최대(max.)	22.2mm
OT 최소(min.)	0.3mm
MD 최대(max.)	1.5mm
OP	20.6±1.0mm

YS R2-15C

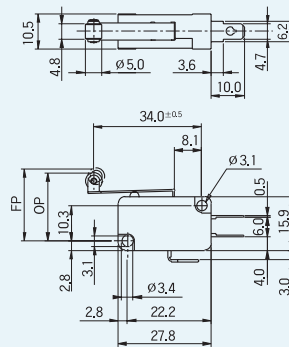

OF 최대(max.)	300gf
RF 최소(min.)	15gf
FP 최대(max.)	23.8mm
OT 최소(min.)	0.6mm
MD 최대(max.)	3.0mm
OP	20.6±1.6mm

YS R3-15C

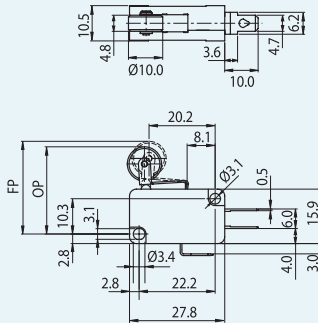

OF 최대(max.)	600gf
RF 최소(min.)	50gf
PT 최대(max.)	1.6mm
OT 최소(min.)	0.3mm
MD 최대(max.)	1.5mm
OP	25.6±1.0mm

외형 / 치수도 | Shape / Dimension Drawing

(unit : mm)

YS RL-15C

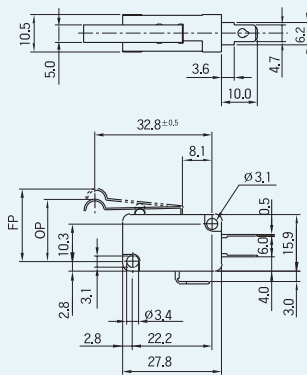

OF 최대(max.)	250gf
RF 최소(min.)	15gf
FP 최대(max.)	21.7mm
OT 최소(min.)	0.6mm
MD 최대(max.)	2.5mm
OP	17.0±1.6mm

YS L1-15C

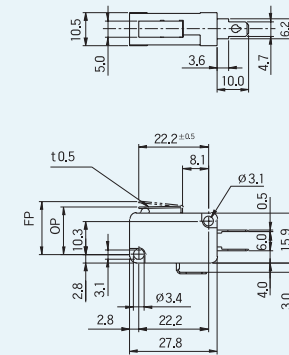
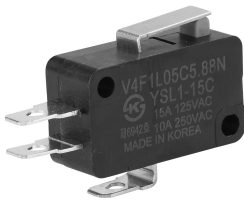

OF 최대(max.)	600gf
RF 최소(min.)	50gf
FP 최대(max.)	16.9mm
OT 최소(min.)	0.3mm
MD 최대(max.)	1.5mm
OP	15.3±0.6mm

YS L2-15C

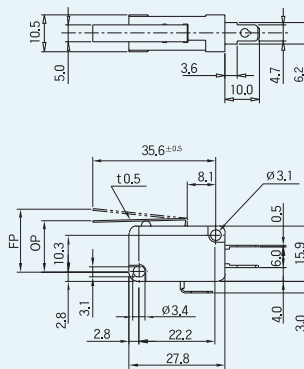

OF 최대(max.)	300gf
RF 최소(min.)	15gf
FP 최대(max.)	18.5mm
OT 최소(min.)	0.6mm
MD 최대(max.)	3.0mm
OP	15.3±1.6mm

YS L3-15C

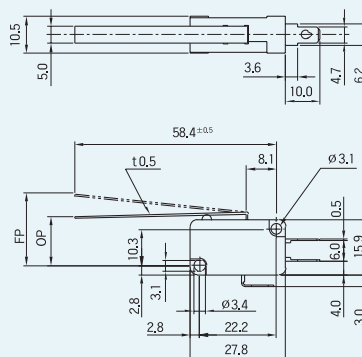
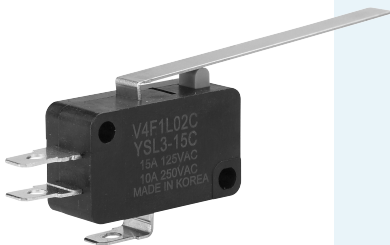

OF 최대(max.)	150gf
RF 최소(min.)	12gf
FP 최대(max.)	21.7mm
OT 최소(min.)	1.0mm
MD 최대(max.)	3.0mm
OP	13.0±1.6mm

외형 / 치수도 | Shape / Dimension Drawing | (unit : mm)

YS P12-15C

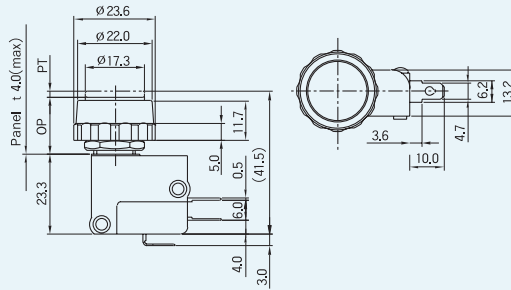

OF 최대(max.)	500gf
RF 최소(min.)	50gf
FP 최대(max.)	1.6mm
OT 최소(min.)	0.3mm
MD 최대(max.)	1.0mm
OP	16.5±0.7mm

YS P9S-15C

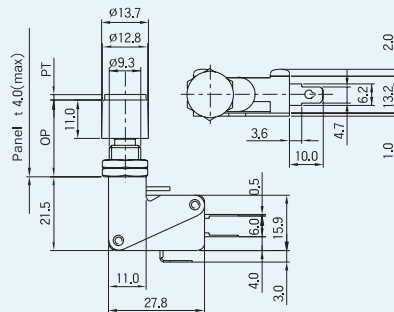

OF 최대(max.)	500gf
RF 최소(min.)	50gf
FP 최대(max.)	1.6mm
OT 최소(min.)	0.3mm
MD 최대(max.)	1.0mm
OP	22.0±0.7mm

YS P9D-15C

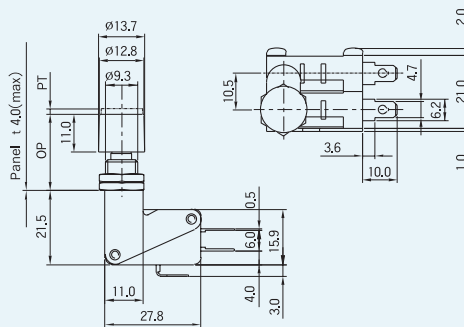
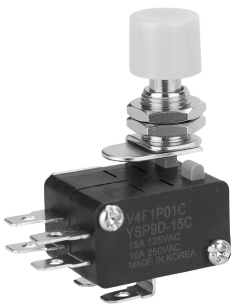

OF 최대(max.)	1,000gf
RF 최소(min.)	50gf
FP 최대(max.)	1.6mm
OT 최소(min.)	0.3mm
MD 최대(max.)	1.0mm
OP	22.0±0.7mm

판넬 가공 치수 | Cut-out Dimension | (unit : mm)

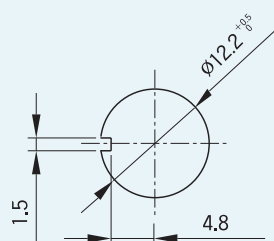

P12 Type

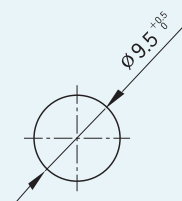

P9S, P9D Type

1-4

리미트 스위치
Limit Switch

-  ■ IP 66

특징 | Features |

- 다이캐스팅 케이스에 2회로쌍단 스위치를 내장시킨 리미트 스위치입니다.
- 기계적 강도가 크고 내열, 내유, 방진, 방수 구조로서 매우 견고하게 설계되어 있습니다.
- TYPE은 로라형, 레바형, 롯데레바형, 푸쉬형 등으로 다양하며, 동작을 확인할 수 있는 램프형은 보수가 용이합니다.
- The limit switch with the built-in 2 circuit double switch in diecasting case.
- Solidly designed with high mechanical strength, heat resistance, oil resistance, vibration-resistance and water-resistance.
- Various type of roller, lever, lot lever, push types etc., and easy maintenance of operation verifiable lamp type.

용도 | Application |

- 각종 공작기계, 자동제어기기 등 용도가 다양함.
- Various use in machine tools, automatic control parts etc.

내부 구조도 | Inside Structure Diagram |





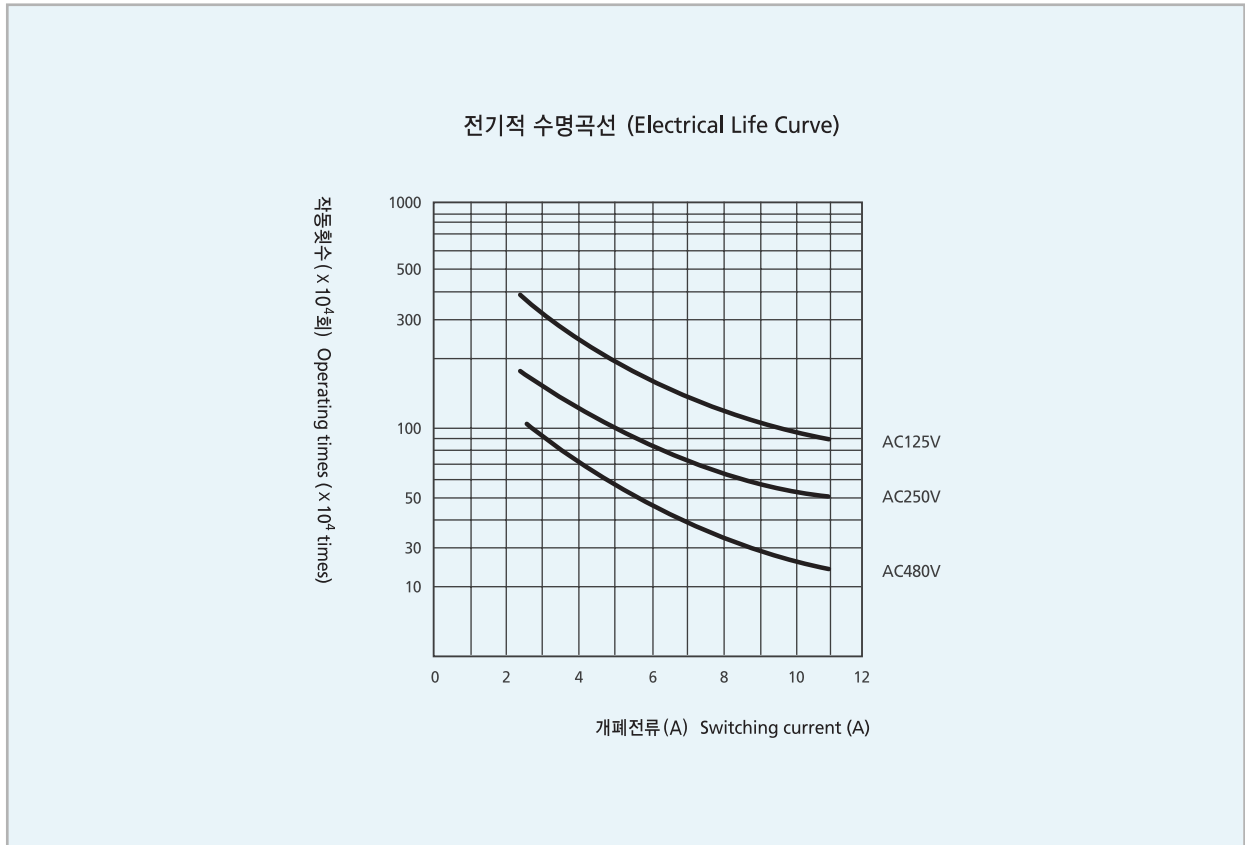







수명 곡선 | Lifetime Curve |



성능 개요 | Performance Summary |

항목 (Item)		성능 (Performance)
절연저항 (Insulation resistance)		Above 100MΩ (DC 500V, Meg)
접촉저항 (Contact resistance)		Below 50mΩ (Initial value)
내전압 (Withstand voltage)		AC 2,500V/min (50~60Hz)
내진동 (Withstand vibration)		10~55Hz, double amplitude 1.5mm
내충격 (Withstand impact)		About 30G (300 ٪)
수명 (Lifetime)	기계적 (Mechanical)	100만회 이상 (20회/분) (Above 1 million times (Switching freq : 20 times/min.))
	전기적 (Electrical)	10만회 이상 (20회/분) (Above 100,000 times (Switching freq : 20 times/min.))
사용주위온도 (Ambient temperature)		-25℃ ~ +55℃
상대습도 (Relative humidity)		45 ~ 85%

종류별 형식 구분 | Type Classification |

분류명 (Classified Type)	형상 (Shape)	형식구분 (Designation)	최대 LEVER 동작각도 (Max. lever operating angle)
로라레바형 (Roller lever type)		YS 511RL	좌우 (Left/Right) 90°
양레바걸림형 (Both lever suspending type)		YS 512RL	좌우 (Left/Right) 90°
로라조절레바형 (Roller adjusting lever type)		YS 513RL	좌우 (Left/Right) 90°
로드스프링레바형 (Rod spring lever type)		YS 513SL	좌우 (Left/Right) 90°
로드조절레바형 (Rod adjusting lever type)		YS 515L	좌우 (Left/Right) 90°
푸시플란저 형 (Push plunger type)		YS 516P	상하 (Top, Bottom)
톱볼형 (Top ball type)		YS 516PB	상하 (Top, Bottom)
로라플란저형 (Roller plunger type)		YS 517RP	상하 (Top, Bottom)
코일스프링형 (Coil spring type)		YS 518S	무지향성 (Non-directional)
대로라레바형 (Large roller lever type)		YS 519RL	좌우 (Left/Right) 90°

접점 구성도 / 내장 스위치 (T형) | Contact Form Diagram / Built-in Switch (T type) |

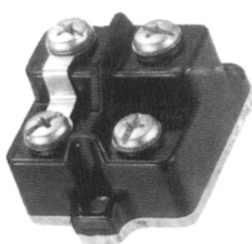
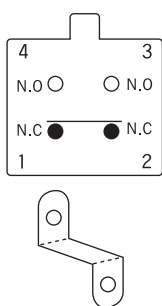

Common 단자 1번, 4번
(Common terminal No.1, No.4)

▶ YS 512(612) RL형 로라 부착 종류
YS 512(612) RL type roller attachment type

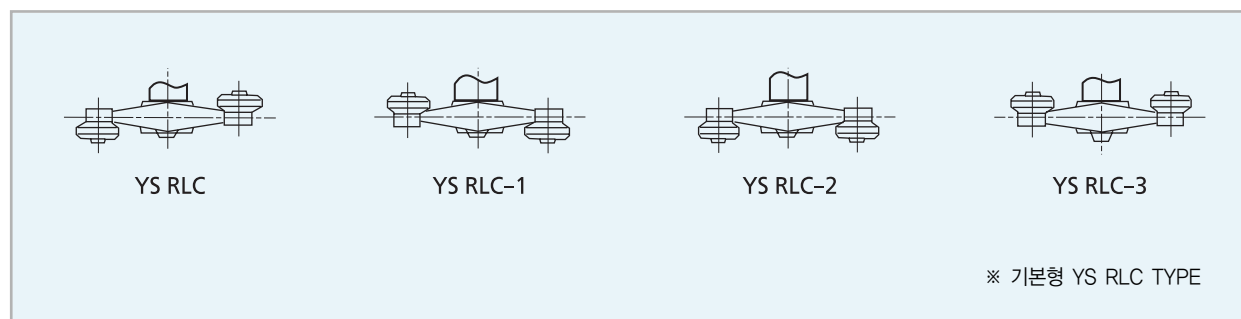

부품 재질 | Part Materials |

부품 (Part)		재질 (Materials)
몸체 (Body)		알루미늄 합금 (Aluminum alloy)
액추에이터 (Actuator)	롤러 (Roller)	Stainless 강 (Stainless steel)
	레버 (Lever)	알루미늄 합금 (Aluminum alloy)
캠 (Cam)		탄소강 (Carbon steel) - 512 아세탈 수지 (Acetal resin) - 511, 513, 515, 519
플란저 (Plunger)		탄소강 (Carbon steel) - 512 아세탈 수지 (Acetal resin) - 511, 513, 515, 519
내장스위치 몸체 (Switch body)		PBT 수지 (PBT resin)
단자 (Terminal)		황동 (Brass)
접점 (Contact)		은산화 카드뮴 합금 (Silver-cadmium oxide alloy)

정격 | Rating |

정격전압(V) (Rating voltage(V))	무유도부하(A) (No-Inductive load(A))				유도부하(A) (Inductive load(A))			
	저항부하 (Resistance load)(cos ϕ =1)		램프부하 (Lamp load)		유도부하 (Inductive load)(cos ϕ =0.4, L/R=7ms)		전동기부하 (Motor load)	
	상시폐로 (Normal close)	상시개로 (Normal open)	상시폐로 (Normal close)	상시개로 (Normal open)	상시폐로 (Normal close)	상시개로 (Normal open)	상시폐로 (Normal close)	상시개로 (Normal open)
AC 125	10	10	3	1.5	10		5	2.5
250	10	10	2	1	10		3	1.5
500	10	10	1.5	0.8	3		1.5	0.8
DC 8	10		6	3	10		6	
14	10		6	3	10		6	
30	6		4	3	6		4	
125	0.8		0.2	0.2	0.8		0.2	
250	0.4		0.1	0.1	0.4		0.1	

- (주)
1. 상기 치수는 정상전류를 표시합니다.
 2. 유도부하는 역률 0.4이상(교류), 시정수 7ms이하(직류) 입니다.
 3. 램프 부하에는 10배의 돌입 전류를 유발합니다.
 4. 전동기 부하에는 6배의 돌입전류를 유발합니다.

- (Note)
1. Above values indicate normal current.
 2. Inductive load is above 0.4 of induction ratio(AC), and below 7ms of time constant(DC).
 3. Rush current of 10 times occurs in lamp load.
 4. Rush current of 6 times occurs in motor load.

형식 구분도 | Type Classification Diagram

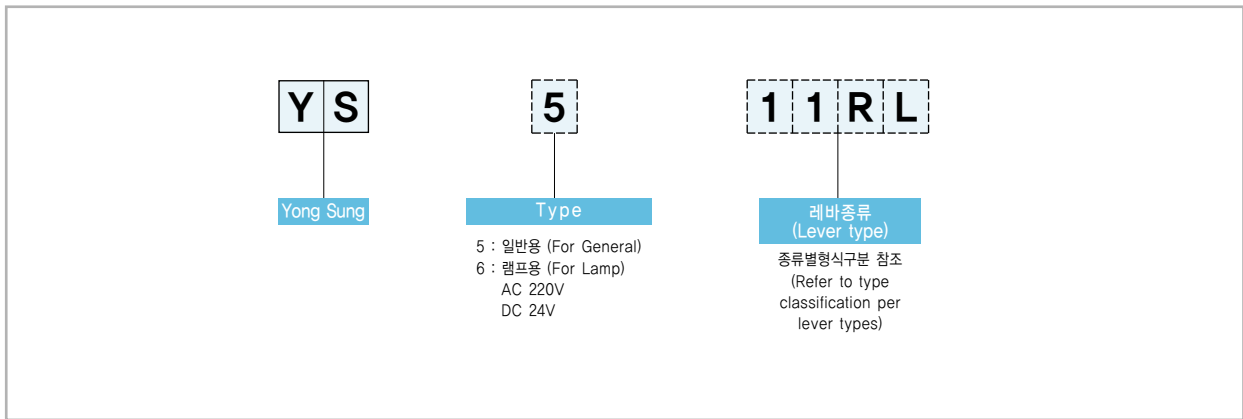

외형 / 치수도 | Shape / Dimension Drawing

(unit : mm)

일반형(General Type) 램프형(Lamp Type)

YS 511RL

YS 611RL

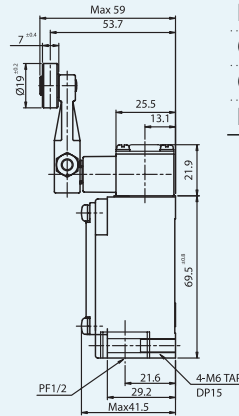
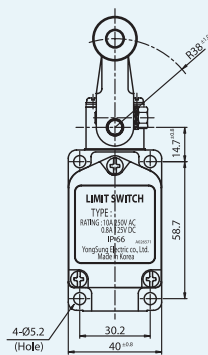

OF 최대(max.)	1400gf
RF 최소(min.)	220gf
OP 최대(max.)	15° ±5°
OT 최소(min.)	30°
MD 최대(max.)	12°

YS 512RL

YS 612RL

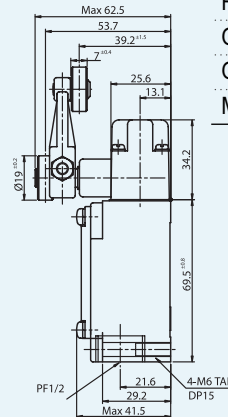
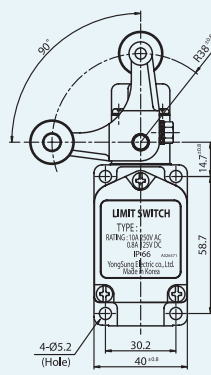

OF 최대(max.)	1200gf
RF 최소(min.)	-
OP 최대(max.)	50° ±5°
OT 최소(min.)	35°
MD 최대(max.)	-

외형 / 치수도 | Shape / Dimension Drawing | (unit : mm)

일반형(General Type) 램프형(Lamp Type)

YS 513RL

YS 613RL

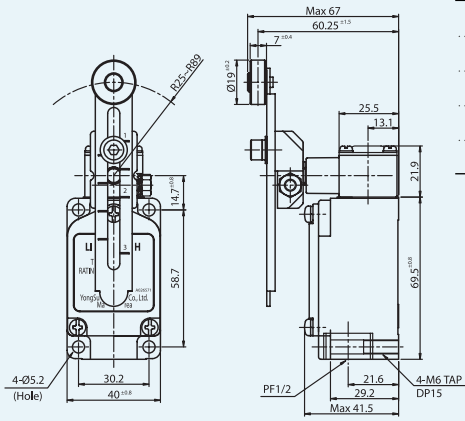

※레버의 길이가 38mm일 경우
(When lever length is 38mm)

OF 최대(max.)	1400gf
RF 최소(min.)	220gf
OP 최대(max.)	15° ±5°
OT 최소(min.)	30°
MD 최대(max.)	12°

YS 513SL

YS 613SL

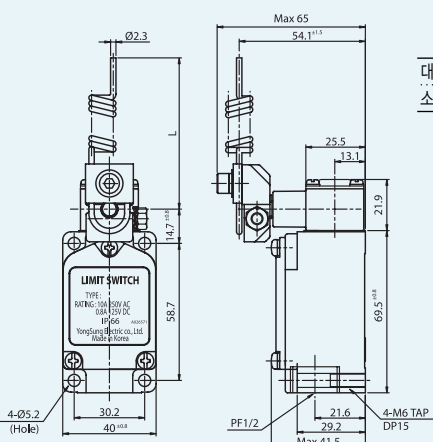
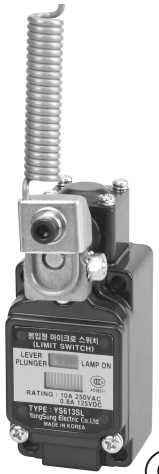

※ L의 전장치수 구분
(Classification of total length dimension L)

대(large)	330 ^{±5}	주문품(ordered product)
소(small)	126.5 ^{±5}	기본품(basic product)

※ L = 126.5mm일 경우
(When L is 126.5mm)

OF 최대(max.)	50gf
RF 최소(min.)	35gf
OP 최대(max.)	15° ±5°
OT 최소(min.)	30°
MD 최대(max.)	12°

YS 515L

YS 615L

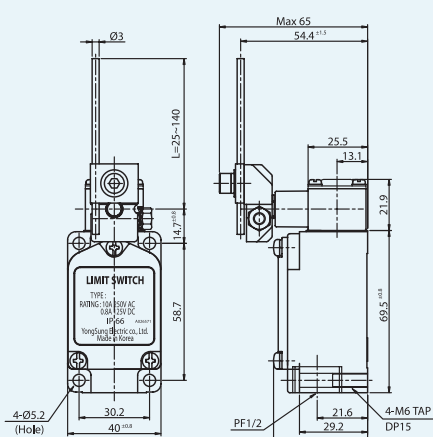

※ L = 140mm일 경우
(When L is 140mm)

OF 최대(max.)	120gf
RF 최소(min.)	40gf
OP 최대(max.)	15° ±5°
OT 최소(min.)	30°
MD 최대(max.)	12°

외형 / 치수도 | Shape / Dimension Drawing

(unit : mm)

일반형(General Type) 램프형(Lamp Type)

YS 516P

YS 616P

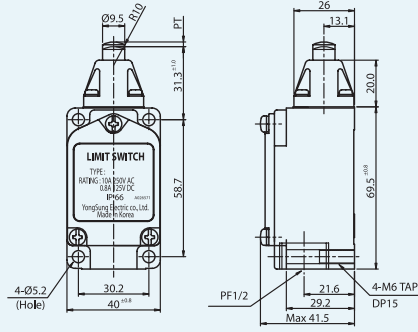

OF 최대(max.)	2800gf
RF 최소(min.)	900gf
PT 최대(max.)	2.0mm
OT 최소(min.)	6.4mm
MD 최대(max.)	1.0mm

YS 516PB

YS 616PB

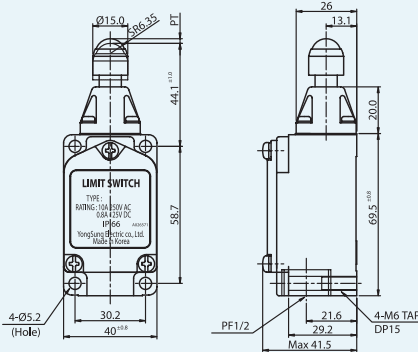

OF 최대(max.)	2800gf
RF 최소(min.)	900gf
PT 최대(max.)	2mm
OT 최소(min.)	6.4mm
MD 최대(max.)	1.0mm

YS 517RP

YS 617RP

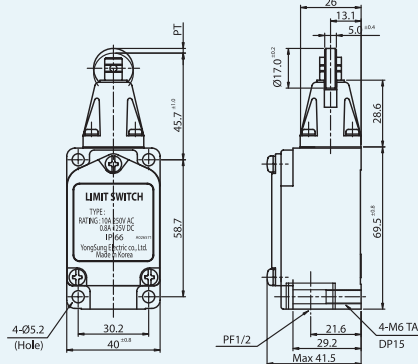

OF 최대(max.)	2800gf
RF 최소(min.)	900gf
PT 최대(max.)	2.0mm
OT 최소(min.)	5.6mm
MD 최대(max.)	1.0mm

외형 / 치수도 | Shape / Dimension Drawing | (unit : mm)

일반형(General Type) 램프형(Lamp Type)

YS 518S

YS 618S

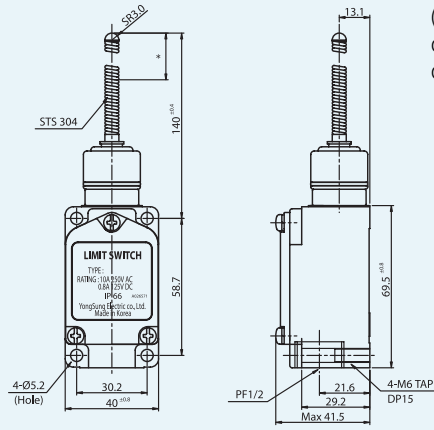

* 조작체의 최적사용범위는 S/P선단에서 S/P전장의 1/3이내일 것
(Optimum using scope of operating body is within 1/3 of S/P full length all S/P end.)

OF 최대(max.)	80gf
RF 최소(min.)	-
PT 최대(max.)	20mm
OT 최소(min.)	-
MD 최대(max.)	-

YS 519RL

YS 619RL

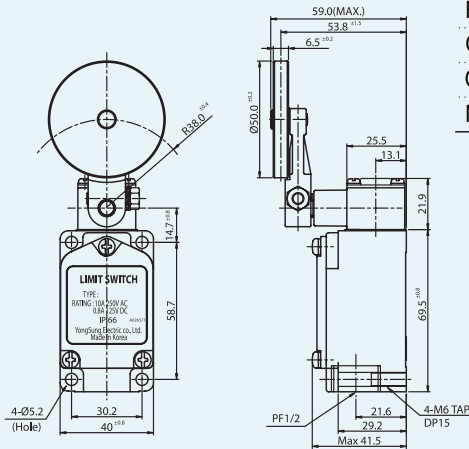

OF 최대(max.)	980gf
RF 최소(min.)	120gf
OP 최대(max.)	15° ±5°
OT 최소(min.)	70°
MD 최대(max.)	10°

1-5

소형 리미트 스위치 Compact Limit Switch

형식 구분도 | Type Classification Diagram |

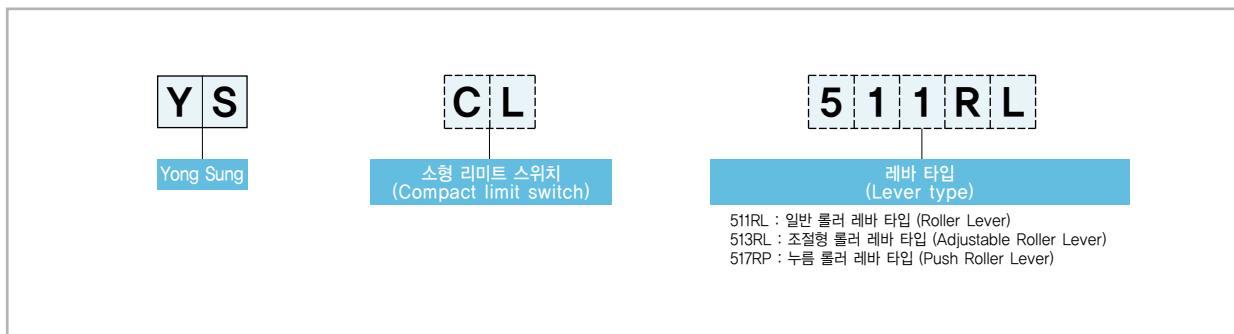

제품 특징 및 구조 | Features and Structure of Product |

- 외형은 알루미늄 다이캐스팅 구조로 되어 있습니다.
- 접점부는 순간반전 구조로 되어 있습니다.
- 기계적 강도가 높고 내열, 내유 방진구조로 되어 있습니다.
- 제품 소형화로 다목적으로 사용할 수 있습니다.
- 사용 용도에 따라 레버를 선택할 수 있습니다.
- 단자부 배선결선이 용이한 구조로 되어 있습니다.
- Shape is made by diecasting case.
- Moment-reverse structure is in contact part.
- High mechanical strength, heat, oil and vibration-resistance.
- Various use as compact size.
- Various lever type is available.
- Easy for wiring at terminal part.

부품 재질 | Part Materials |

No	부품 (Part)	재질 (Materials)
1	헤드, 몸체 (Head, Body)	알루미늄 합금 (Al alloy)
2	접점 블록 (Contact block)	PBT 수지 (PBT resin)
3	보호 카바 (Protection cover)	PC 수지 (Polycarbonate resin)
4	접점 (Contact)	은접점 (Silver)
5	단자 (Terminal)	황동 (Brass)
6	볼트류 (Bolts)	탄소강 (Carbon steel)
7	카바 (Cover)	PBT 수지 (PBT resin)
8	레버 (Lever)	냉간압연 강판 (Cold rolled steel sheets)
9	롤러 (Roller)	스테인레스 (Stainless steel)

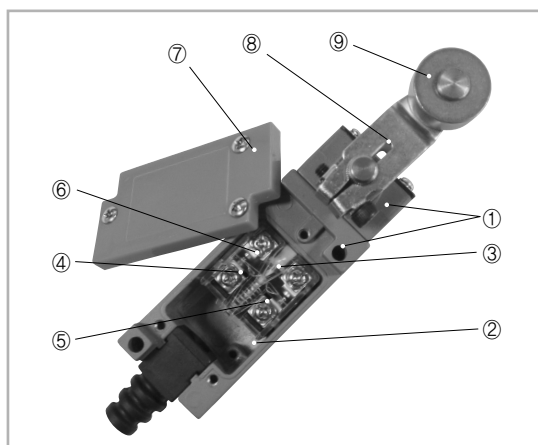

성능 및 사용조건 | Performance and Using Condition |

보호등급 (Degree of protection)		IP 65
허용조작속도 (Allowable operating speed)		5 mm/s to 0.5 m/s
내구성 (Durability)	기계적수명 (Mechanical lifetime)	Above 1,000,000 times (20 times/min)
	전기적수명 (Electrical lifetime)	Above 100,000 times (20 times/min)
개폐빈도 (Switching frequency)	기계적 (Mechanical)	20 times/min
	전기적 (Electrical)	20 times/min
절연저항 (Insulation resistance)		Above 100M Ω (DC 500V. Meg)
접촉저항 (Contact resistance)		Below 50m Ω (Initial value)
내전압 (Withstand voltage)		AC 1,500V/min (50~60Hz)
내진동 (Withstand vibration)	오동작 (Malfunction)	Double amplitude 1.5 mm (10~55Hz)
내충격 (Withstand impact)	내구 (Endurance)	1,000 m/s ² (About 100G)
	오동작 (Malfunction)	300 m/s ² (About 30G)
사용주위온도 (Ambient temperature)		-25°C ~ +55°C (단, 결로되지 않는 조건) (When condensation is not.)
상대습도 (Relative humidity)		45 ~ 85%

접점 정격 | Contact Rating |

정격전압 (Rating Voltage)	무유도부하 (Non-inductive load)				유도부하 (Inductive load)			
	저항부하 (Resistance load)		램프부하 (Lamp load)		유도부하 (Inductive load)		전동기부하 (Motor load)	
	상시폐로 (NC)	상시개로 (NO)	상시폐로 (NC)	상시개로 (NO)	상시폐로 (NC)	상시개로 (NO)	상시폐로 (NC)	상시개로 (NO)
125V AC	5		1.5	0.7	3		2	1
250V AC	5		1	0.5	3		1.5	0.8
12V DC	5		3		4		3	
24V DC	5		3		4		3	
125V DC	0.4	0.2	-		-		-	
250V DC	0.4	0.2	-		-		-	

외형 / 치수도 | Shape / Dimension Drawing

(unit : mm)

YS CL 511RL

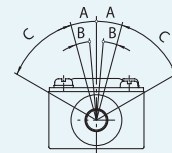
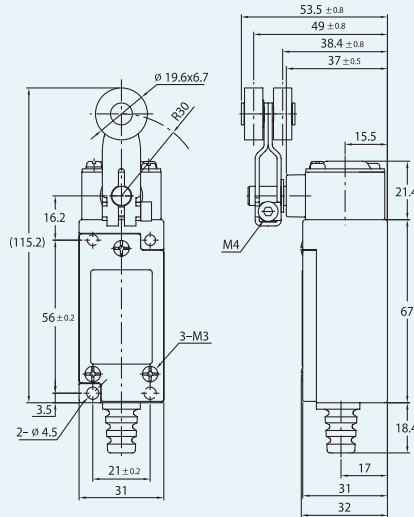
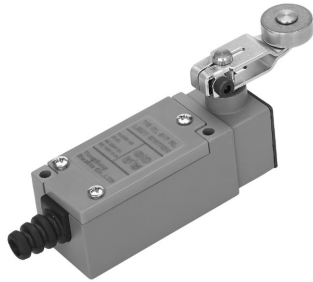

동작 특성 (Operating Characteristics)

	표준각도
A (동작각도) OP max.	15° ±5°
B (복귀각도) MD max.	8° ±3°
C (동작 후 이동각도) OT min.	30°
OF max. (동작에 필요한 힘)	7.5N
RF max. (동작후 되돌림의 힘)	0.7N

YS CL 513RL

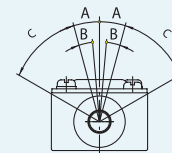
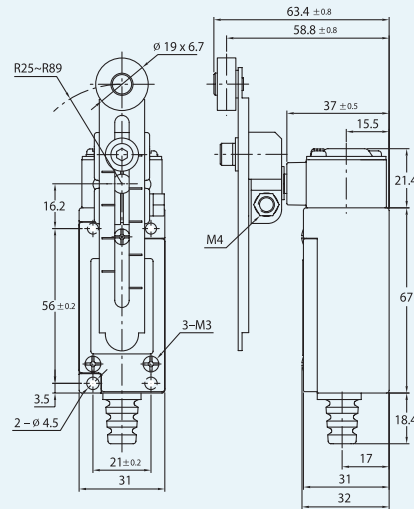
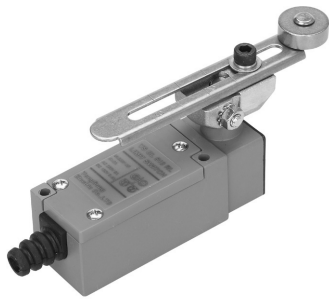

동작 특성 (Operating Characteristics)

	표준각도
A (동작각도) OP max.	15° ±5°
B (복귀각도) MD max.	8° ±3°
C (동작 후 이동각도) OT min.	30°
OF max. (동작에 필요한 힘)	7.5N
RF max. (동작후 되돌림의 힘)	0.7N

YS CL 517RP

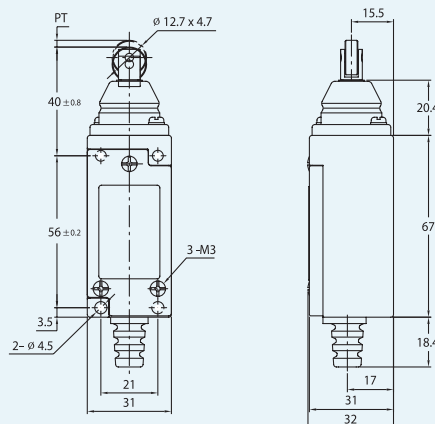

동작 특성 (Operating Characteristics)

	단위 (mm)
OP max. (동작각도)	2.0±0.3
OT min. (동작 후 이동각도)	6.6
MD max. (복귀거리)	1.1±0.3
OF max. (동작에 필요한 힘)	9.7N
RF max. (동작후 되돌림의 힘)	1N

접점 구성도 | Contact Diagram |

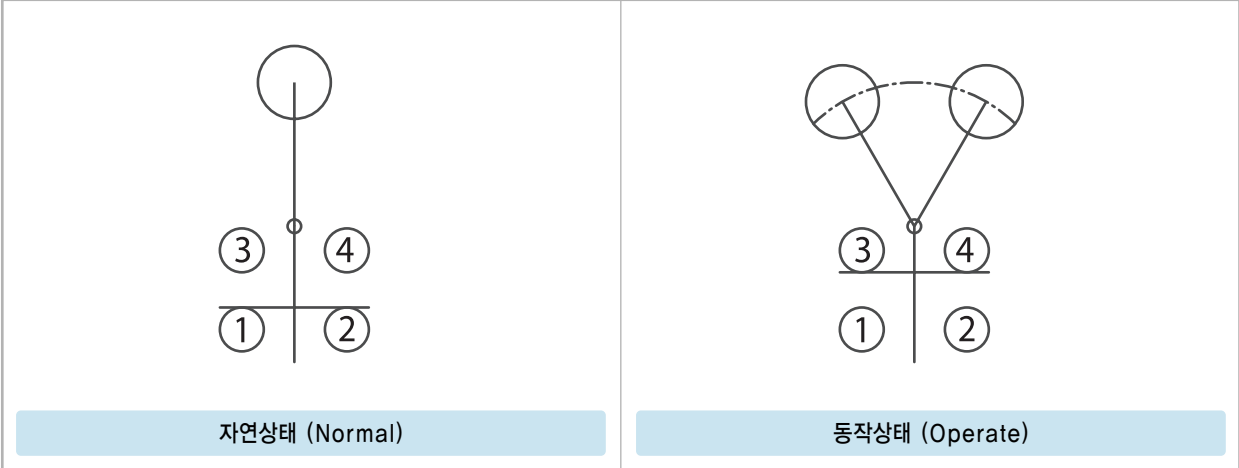

적용 전선 | Applicable Lead Wires |

도체 굵기 (단면적) (Conductor Size)	케이블 외형 사이즈 (External Size)
0.75 mm ² ~ 2 mm ²	원형 (Round) : Ø6 ~ Ø9 사각형 (Square) : 최대(Max.) 9.4

※ 실리콘 전선은 사용하지 마십시오. 실리콘 전선을 사용할 경우 접촉불량을 초래할 수 있습니다.
 (Do not use Silicone cable. It may cause contact inferiority.)

사용 가능 압착 단자 | Applicable Terminal |

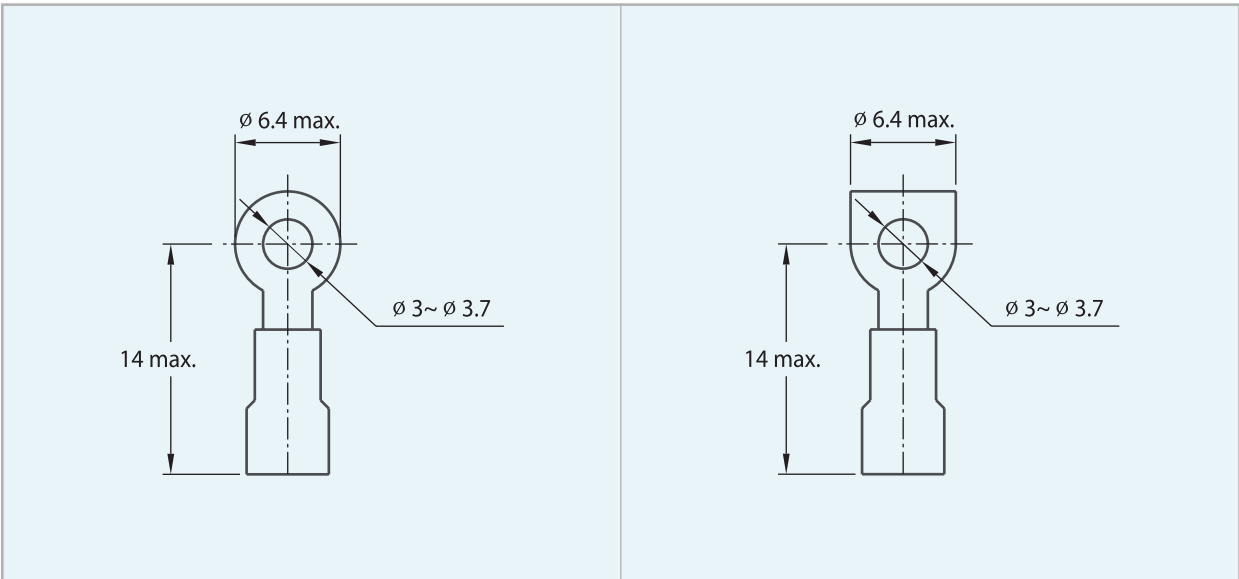

※ U단자는 사용하지 마십시오. U단자를 사용할 경우 분리의 위험이 있어, 접촉불량을 초래할 수 있습니다.
 (Do not use U terminal. It may cause contact inferiority by separation.)

배선 방법 | Wiring

- 1) ①카바 고정 볼트(3개)를 풀고, ②카바를 제거합니다.
 - 2) 소형리미트 스위치의 ③고무 컨넥터를 분리하고, 전선을 고무 컨넥터에 삽입후 ④압착단자를 체결합니다.
 - 3) ⑤단자볼트를 풀고 압착단자 삽입후 풀리지 않도록 단단히 조입니다. (조임토크 0.49 ~ 0.59 N·m)
 - 4) 배선 완료후 고무 컨넥터를 소형리미트 스위치의 홈에 맞게 삽입합니다.
 - 5) 배선 이상 유무 확인 후 카바를 덮고 고정 볼트를 조여 마무리 합니다. (조임토크 0.49 ~ 0.59 N·m)
- 1) Unscrew ①cover bolt(3pcs), then remove cover.
 - 2) Separate ③rubber connector, then insert wire into rubber connector, then ④put in solderless terminal.
 - 3) Unscrew ⑤terminal bolt, then insert solderless terminal, then screw terminal bolt.
(Tightness torque 0.49 ~ 0.59 N·m)
 - 4) After completing wiring, insert rubber connector into limit switch.
 - 5) After checking wiring, put on cover, then screw cover bolt. (Tightness torque 0.49 ~ 0.59 N·m)

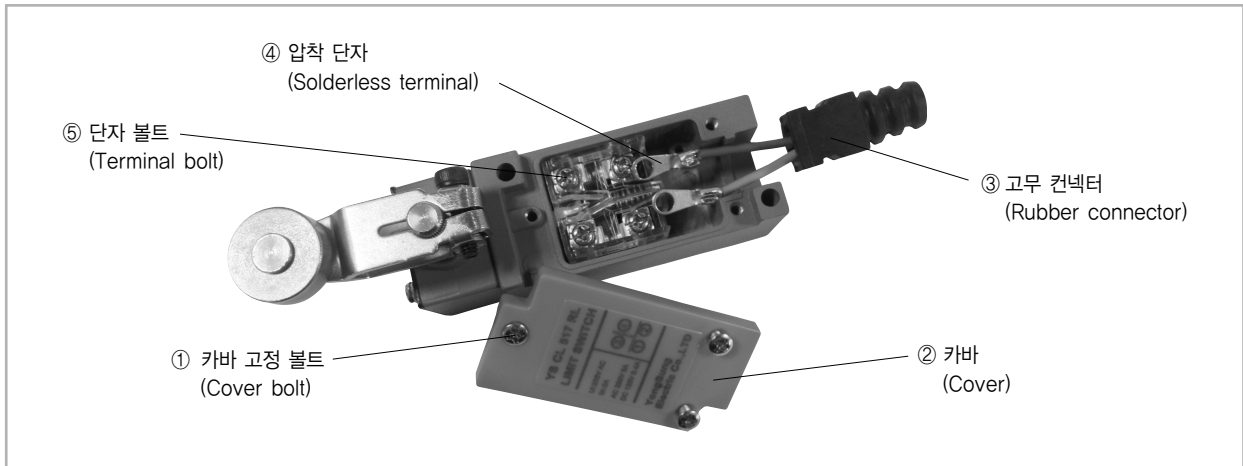

헤드 위치 변경 | Head Direction Change

헤드 방향을 변경하려면 두 개의 헤드 위치 변경 볼트를 풀고, 헤드를 원하는 방향 (90°)으로 변경후 두 개의 헤드 위치 변경 볼트를 조여 마무리 합니다.

Unscrew two head mounting screw, moving head direction(90°), then screw two head mounting screw.

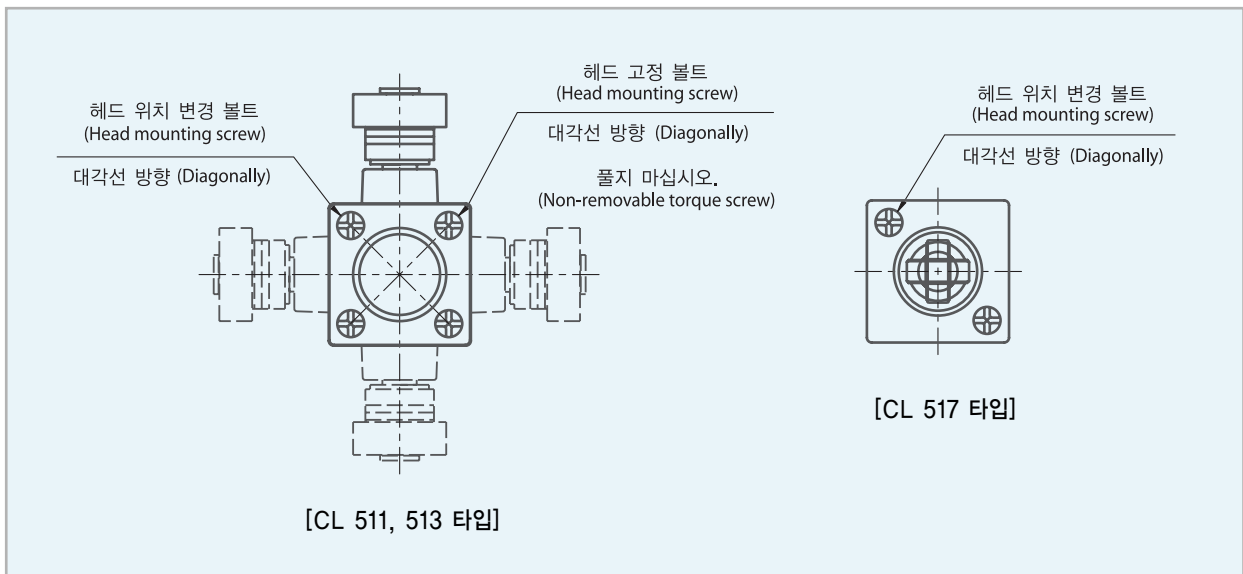

패널 가공 치수 | Cut - out Dimension |

(unit : mm)

- 1) 소형리미트 스위치를 안전하게 부착하기 위해선 두 개의 M4 탭을 가공하여 사용하여야 합니다.
 - 2) 부착시 와셔볼트를 사용하여 진동에 풀리지 않도록 대비하여야 합니다.
- 1) Need to use two M4 screws to install limit switch safely.
 - 2) Use washer bolt not to release limit switch by vibration when installing the switch.

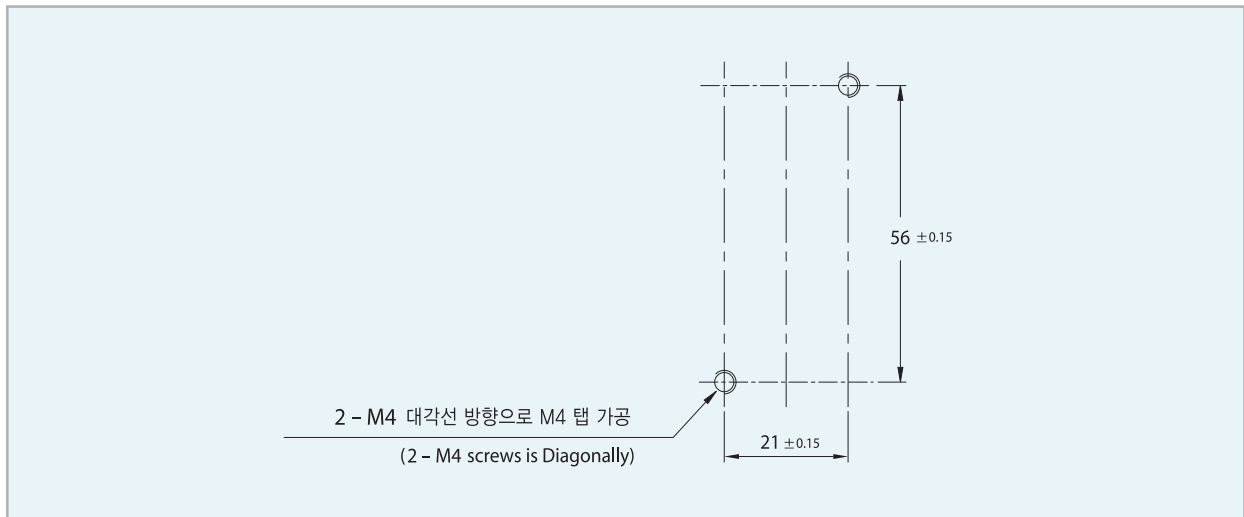

사용시 주의사항 | Precautions for Correct Use |

- 1) 소형리미트 스위치 사용환경이 가혹한 경우(기름, 용매, 화학물질 등) 기밀기능이 저하될 수 있습니다.
항상 실제 사용조건에서 성능을 평가하고 적절한 유지 보수 및 교체 기간을 설정하십시오.
 - 2) 산업용 기계 부착 사용시 절삭칩, 먼지 등이 유입되지 않는 곳에 설치해 주십시오.
 - 3) 과도한 충격이나 진동은 소형리미트 스위치의 기능에 직접적으로 영향을 미치므로 충격과 진동이 없는 곳에 설치해 주십시오.
 - 4) 소형리미트 스위치는 물리적 접촉(접점)으로 구성되어 있습니다. 실리콘 가스(Silicon gas)가 포함된 대기환경에서 사용할 경우 아크에 의해 산화 규소(SiO₂)가 발생하고, 산화 규소가 접촉(접점)부위에 응집될 경우 접촉불량을 초래할 수 있습니다.
따라서 소형리미트 스위치 사용 시 주변에 실리콘오일, 실리콘보관함, 실리콘케이블 등과 같은 실리콘재료의 제품이 있다면, 아크 억제 보호회로(서지킬러) 설치 또는 실리콘가스를 제거할 수 있는 장치가 필요합니다.
 - 5) 소형리미트 스위치 설치 시 직사광선 및 침수, 강수에 노출되지 않도록 설치해 주십시오. 녹이나 오존에 의해 손상될 수 있습니다.
 - 6) 소형리미트 스위치는 빗물, 해수, 기름에 지속적으로 노출되는 장소에는 적합하지 않습니다.
 - 7) 사용주위 온도가 영하일 경우 소형리미트 스위치가 결빙되지 않도록 보호해 주십시오.
스위치 결빙 시 동작불량 및 접촉불량을 초래할 수 있습니다.
- 1) In case of harsh condition(oil,solvent,chemical substance) for use, airtight function would be reduced.
Always do evaluate performance on usage condition, set up period of replacement and maintenance.
 - 2) When use limit switch on industrial machine, install it at place where there is no dust.
 - 3) Excessive shock and vibration affect function of limit switch directly.
So, install the switch at place where there is no shock and vibration.
 - 4) Limit switch consists of physical contact. When use the switch in atmosphere including Silicon gas, SiO₂ may occur by Arc and it may cause contact inferiority on contact part. Therefore if there is any Silicon things such as Silicon oil, a box keeping Silicon, Silicon cable nearby the switch, surge killer or any device that remove Silicon gas is needed.
 - 5) Do not expose limit switch from direct ray of light, flood, rainfall. Rust or ozone may damage the switch.
 - 6) Limit switch is not suitable at place where there is constant rainwater, seawater, oil.
 - 7) Do protect limit switch on minus degree. Frozen switch may cause operation and contact inferiority.