

Easy Series

EasyPact™ EVS

Catalog 2021

Molded-case circuit breakers
from 16 to 630A



<https://www.se.com>

Life Is On

Schneider
Electric



Green Premium™

An industry leading portfolio of offers delivering sustainable value



More than 75% of our product sales offer superior transparency on the material content, regulatory information and environmental impact of our products:

- RoHS compliance
- REACH substance information
- Industry leading # of PEP's*
- Circularity instructions



Discover what we mean by green
[Check your products!](#)

The Green Premium program stands for our commitment to deliver customer valued sustainable performance. It has been upgraded with recognized environmental claims and extended to cover all offers including Products, Services and Solutions.

[CO₂ and P&L impact through... Resource Performance](#)

Green Premium brings improved resource efficiency throughout an asset's lifecycle. This includes efficient use of energy and natural resources, along with the minimization of CO₂ emissions.

[Cost of ownership optimization through... Circular Performance](#)

We're helping our customers optimize the total cost of ownership of their assets. To do this, we provide IoT-enabled solutions, as well as upgrade, repair, retrofit, and remanufacture services.

[Peace of mind through... Well-being Performance](#)

Green Premium products are RoHS and REACH compliant. We're going beyond regulatory compliance with step-by-step substitution of certain materials and substances from our products.

[Improved sales through... Differentiation](#)

Green Premium delivers strong value propositions through third-party labels and services. By collaborating with third-party organizations we can support our customers in meeting their sustainability goals such as green building certifications.

*PEP: Product Environmental Profile (i.e. Environmental Product Declaration)



Fundamentals of protection...

Inherited from the design and technology of the top-selling EasyPact range of MCCB worldwide, EasyPact EZS is an economical solution that is the best value for money in its class. It is specially designed and dedicated to small-medium sized buildings, factories, OEMs and many simple yet demanding applications.

EasyPact EZS is equipped with a classic Schneider Electric inbuilt TM-D thermal-magnetic trip unit, ranging from 16 to 630A. Accessories are common and compatible with the entire EasyPact range of MCCB.

The easy choice for affordable price

Easy to choose

- > From 16 to 630A
- > Up to 50kA at 415V
- > Up to 4 poles
- > Up to 3 frame sizes

Easy to install

- > Fixed front mounting
- > Front connections
- > Field-installable auxiliaries and accessories
- > Installation video through QR Code

Easy to use

- > Hassle-free on any setting requirements
- > Small size optimised for tight spaces
- > Positive contact indication for safety and reliability

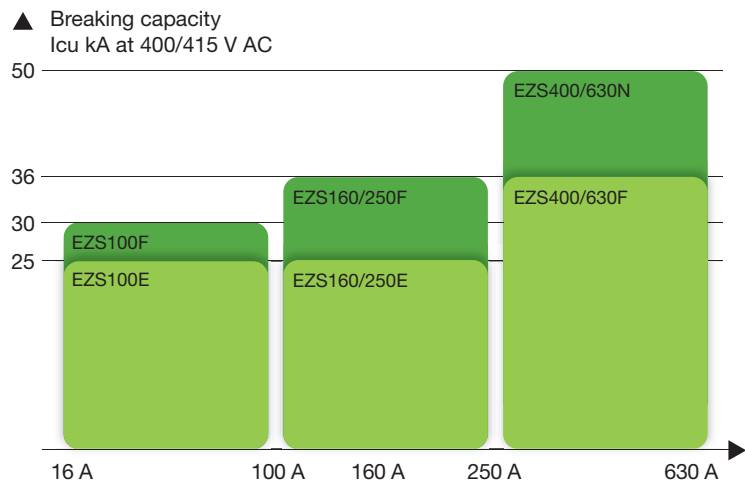

Timely
delivery,
wherever
you are

Schneider Electric offers a world-renowned logistics network capable of getting EasyPact™ EZS products to you fast, wherever you are.

Functions and characteristics **A-1**



Installation recommendations **B-1**



Dimensions and connection **C-1**



Technical data supplement **D-1**



Catalogue numbers **E-1**





Functions and characteristics

<i>Presentation</i>	III
Introduction	A-2
General characteristics	A-2
Characteristics and performance	A-4
Protection of distribution systems	A-6
Accessories and auxiliaries	A-7
Overview	A-7
Device installation	A-8
Selection of auxiliaries	A-9
Indication contacts	A-10
Remote tripping	A-11
Rotary handles	A-12
<i>Installation recommendations</i>	B-1
<i>Dimensions and connection</i>	C-1
<i>Technical data supplement</i>	D-1
<i>Catalogue numbers</i>	E-1

EasyPact

EZS160F 

Ui	690V	
Uimp	8kV	
Ue(V~)	Icu(kA)	Ics(kA)
220/240	70	70
380/400	36	36
415	36	36
440	36	18

50/60Hz **Cat. A**

IEC/EN60947-2

Standardised characteristics indicated on the rating plate:

- 1 Type of device: frame size and breaking capacity class
- 2 Ui: rated insulation voltage.
- 3 Uimp: rated impulse withstand voltage.
- 4 Ue: operational voltage.
- 5 Icu: ultimate breaking capacity for various values of the rated operational voltage Ue.
- 6 Ics: service breaking capacity.
- 7 Suitable for Isolation symbol.
- 8 Reference standard.

Note: when the circuit breaker is equipped with an extended rotary handle, the door must be opened to access the rating plate.

Compliance with standards

EasyPact EZS circuit breakers and auxiliaries comply with the following international recommendations:

- IEC 60947-1: general rules.
- IEC 60947-2: circuit breakers.

Pollution degree

EasyPact EZS circuit breakers are certified for operation in pollution-degree III environments as defined by IEC standards 60947-1 and 60664-1 (industrial environments).

Climatic withstand

EasyPact EZS circuit breakers have successfully passed the tests defined by the following standards for extreme atmospheric conditions:

- IEC 60068-2-1: dry cold (-55°C).
- IEC 60068-2-2: dry heat (+85°C).
- IEC 60068-2-30: damp heat (95 % relative humidity at 55°C).
- IEC 60068-2-52 severity level 2: salt mist.

Environment

EasyPact EZS respects the European environment directive EC/2002/95 concerning the restriction of hazardous substances (RoHS).

All EasyPact EZS production sites have set up an ISO 14001 certified environmental management system.

Ambient temperature

- EasyPact EZS circuit breakers can be used between -25°C and +70°C. For temperatures higher than 40°C (65°C for circuit breakers used to protect motor feeders), devices must be derated ([see page B-2](#)).
- Circuit breakers should be put into service under normal ambient, operating-temperature conditions. Exceptionally, the circuit breaker can be put into service when the ambient temperature is between -35°C and -25°C.
- The permissible storage-temperature range for EasyPact EZS circuit breakers in the original packing is -50°C and +85°C.

Suitable for isolation with positive contact indication

All EasyPact EZS circuit breakers are suitable for isolation as defined in IEC standard 60947-2:

- The isolation position corresponds to the O (OFF) position.
- The operating handle cannot indicate the OFF position unless the contacts are effectively open.
- Padlocks cannot be installed unless the contacts are open.

Installation of a rotary handle does not alter the reliability of the position-indication system.

The isolation function is certified by tests guaranteeing:

- The mechanical reliability of the position-indication system.
- The absence of leakage currents.
- Over voltage withstand capacity between upstream and downstream connections.

The tripped position does not ensure isolation with positive contact indication. Only the OFF position guarantees isolation.

Installation in class II switchboards

All EasyPact EZS circuit breakers are class II front face devices. They can be installed through the door of class II switchboards (as per IEC standards 61140 and 60664-1) without downgrading switchboard insulation. Installation requires no special operations, even when the circuit breaker is equipped with a rotary handle.

Degree of protection

The following indications are in accordance with standards IEC 60529 (IP degree of protection) and IEC 62262 (IK protection against external mechanical impacts).

Bare circuit breaker with Escutcheon:

- with toggle: IP40, IK07 front face.
- with extended rotary handle: IP 54, IK08.

Circuit breaker installed in a switchboard:

- with toggle: IP40, IK07 front face.
- with extended rotary handle: IP 54, IK08.



EasyPact EZS100E/F



EasyPact EZS160/250



EasyPact EZS400/630

Common characteristics

Rated voltage			
Insulation voltage (V)	Ui		690
Impulse withstand voltage (kV)	Uimp		8 ⁽¹⁾
Operational voltage (V)	Ue	AC 50/60 Hz	440
Suitability for isolation		IEC/EN 60947-2	■
Utilisation category			A
Pollution degree		IEC 60664-1	3
Control		Manual	Toggle ■ Direct or extended rotary handle ■

Circuit breakers

Performance

Electrical characteristics as per IEC 60947-2

Rated current (A)	In	40°C	
Number of poles			
Breaking capacity levels			
Breaking capacity (kA rms)			
	Icu	AC 50/60 Hz	220/240 V 380/400 V 415V 440 V
Service capacity (kA rms)			
	Ics	AC 50/60 Hz	220/240 V 380/400 V 415V 440 V
Durability (C-O cycles)		Mechanical	
		Electrical	415V In/2 In

Protection

Short-circuit protection	Magnetic only
Overload/short-circuit protection	Thermal magnetic
	Electronic with neutral protection (Off-0.5-1)
Earth-leakage protection	By Vigi module

Auxiliaries

Auxiliary contacts	OF
	SD
Voltage releases	MX
	MN

Installation / connections

Dimensions and weights

Dimensions (mm)	Fixed, front connections	3P 4P
W x H x D		
Weight (kg)	Fixed, front connections	3P 4P

Connections

Connection terminals (mm)	Pitch	Without / With spreaders
Large Cu or Al cables	Cross-section	mm ²
Connection	Fixed	Front connection

(1) Uimp for EZS100 = 6kV.



	EVS100		EVS160		EVS250		EVS400		EVS630	
	16, 20, 25, 32, 40, 50, 63, 80, 100		100, 125, 160		200, 225, 250		315, 350, 400		500, 600	
	3, 4		3, 4		3, 4		3, 4		3, 4	
	E	F	E	F	E	F	F	N	F	N
	50	60	40	70	40	70	40	70	40	70
	25	30	25	36	25	36	36	50	36	50
	25	30	25	36	25	36	36	50	36	50
	17	20	20	36	20	36	30	42	30	42
	25	30	40	70	40	70	40	70	40	70
	15	17	25	36	25	36	36	50	36	50
			25	36	25	36	36	50	36	50
			15	18	15	18	23	32	23	32
	13000		25000		20000		15000		15000	
	4000		25000		20000		12000		8000	
	-		12000		10000		6000		4000	
					■					
					■					
					■					
					■					
					■					
					■					
	75 x 130 x 60		105 x 161 x 86			140 x 255 x 110				
	100 x 130 x 60		140 x 161 x 86			185 x 255 x 110				
	0.78		1.8		2.0	4.7		5.2		
	1.0		2.3		2.6	6.3		7.1		
	25/35		35/45			45/52.5				
						45/70				
	50		300			4 x 240				
	■		■			■				

TM-D thermal-magnetic trip units can be used on EasyPact EZS100-630 circuit breakers with performance levels E/F/N.

TM-D thermal-magnetic trip units

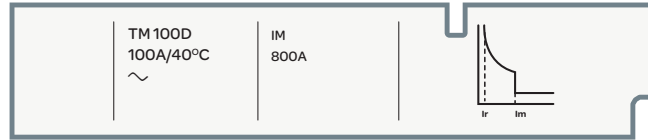

Protection



TM-D trip units are used mainly in electrical distribution applications for protection of cables supplied by transformers.

Thermal protection (Ir)

Thermal protection operates according to:

- Ir non-adjustable.
- non-adjustable time delay.

Magnetic protection (Im)

Short-circuit protection with a fixed or adjustable pick-up I_m that initiates instantaneous tripping if exceeded.

- fixed pick-up.

Protection versions

- 3-pole:
 - 3P 3D: 3-pole frame (3P) with detection on all 3 poles (3D).
- 4-pole:
 - 4P 3D: 4-pole frame (4P) with detection on 3 poles (3D).

Thermal-magnetic trip units		TM16D to 250D										TM320D to 600D									
Ratings (A)	I_n at 40 °C ⁽¹⁾	16	20	25	32	40	50	63	80	100	125	160	200	225	250	315	350	400	500	600	
Circuit breaker	EZS100	■	■	■	■	■	■	■	■	■											
	EZS160									■	■	■									
	EZS250												■	■	■						
	EZS400															■	■	■	■		
	EZS630																		■	■	■
Magnetic protection																					
Pick-up (A)	I_m	fixed																			
accuracy ±20 %	EZS100	300	300	300	300	500	500	750	1000	1000											
	EZS160									800	1250	1250									
	EZS250												2000	2500	2500						
	EZS400															3200	3500	4000			
	EZS630																		5000	5000	
Thermal protection																					
Pick-up (A)	$I_r = I_n$	fixed																			
Neutral protection																					
Unprotected neutral	4P 3D	no detection																			

(1) For temperatures not equal to 40°C, the thermal protection characteristics are modified. See the temperature derating table on page B-2.

Insulation accessories ▶ E-3, E-6, E-9

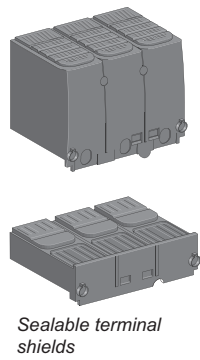

Connection ▶ B-3

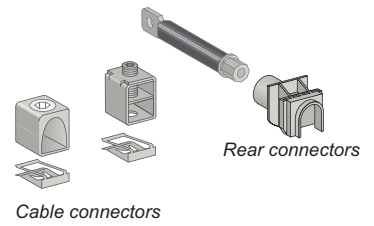
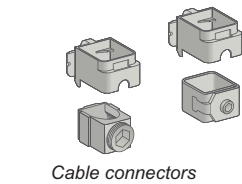
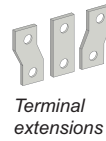

Electrical auxiliaries ▶ A-11

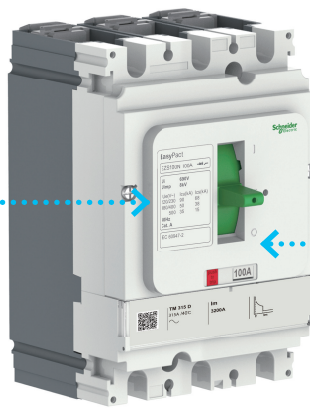
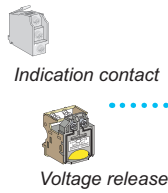

Control accessories ▶ A-12

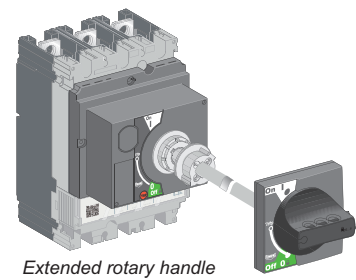
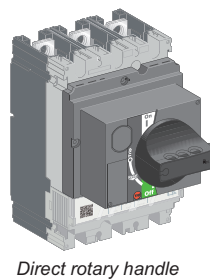

EZS circuit breakers may be installed horizontally, vertically or flat on their back, without derating performance levels.

Fixed circuit breakers

Fixed circuit breakers are designed for standard connection using bars or cables with lugs. Bare-cable connectors are available for connection to bare copper or aluminium cables.

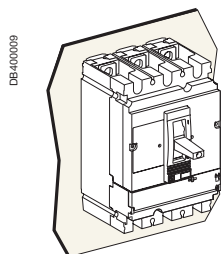

Mounting on a backplate.

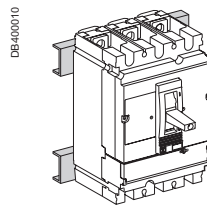

Mounting on rails.

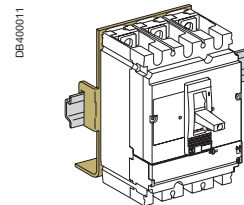

Mounting on DIN rail (with adaptor).

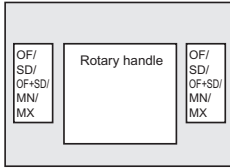

EasyPact EZS100

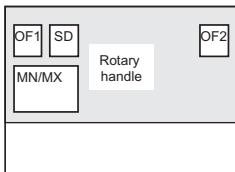

EasyPact EZS160-250

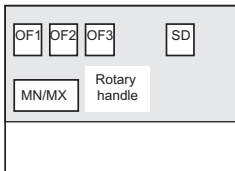

EasyPact EZS400-630

EasyPact EZS160/250

Standard

All EasyPact EZS160~250 circuit breakers have slots for the electrical auxiliaries listed below.

3 indication contacts (see page A-10)

- 2 ON/OFF (OF1 and OF2).
- 1 trip indication (SD).

1 remote-tripping release (see page A-11)

- either 1 MN undervoltage release.
- or 1 MX shunt release.

All these auxiliaries can be installed with a rotary handle.

EasyPact EZS400/630

Standard

All EasyPact EZS400/630 circuit breakers have slots for the electrical auxiliaries listed below.

4 indication contacts (see page A-10)

- 3 ON/OFF (OF3).
- 1 trip indication (SD).

1 remote-tripping release (see page A-11)

- either 1 MN undervoltage release.
- or 1 MX shunt release.

All these auxiliaries can be installed with a rotary handle.

One contact model provides circuit-breaker status indications (OF - SD).



EasyPact EZS100 auxiliary switch



For EasyPact EZS100

These common-point changeover contacts provide remote circuit-breaker status information.

They can be used for indications, electrical locking, relaying, etc. They comply with the IEC 60947-5 international recommendation.

EasyPact EZS100

Indication contacts

Provide remote circuit breaker status information.

They can be used for indications, electrical locking, relaying, etc. Common-point changeover contacts.

Auxiliary switch (ON/OFF)

AX indicates the position of the circuit breaker contacts.

Alarm switch (trip indication)

■ AL indicates that the circuit breaker has tripped due to:

- an overload.
- a short-circuit.
- operation of a voltage release.

They return to de-energised state when the circuit breaker is reset.

Characteristics

Contacts

Rated thermal current (A)	5	
Minimum load	10 mA at 24 V	
Utilisation category (IEC 60947-5-1)	AC12	AC15
Operational current (A)	24 V	5
	48 V	5
	125 V	5
	250 V	3

Connections

Connection wire length	450 mm
Cross-section	EZS100: 1 mm ²
	EZS250: 1.5 mm ²

EasyPact EZS160-630

Functions

Breaker-status indications, during normal operation or after a fault

A single type of contact provides all the different indication functions:

- OF (ON/OFF) indicates the position of the circuit breaker contacts.
- SD (trip indication) indicates that the circuit breaker has tripped due to:
 - an overload.
 - a short-circuit.
 - operation of a voltage release.
 - operation of the "push to trip" button.
 - disconnection when the device is ON.

The SD contact returns to de-energised state when the circuit breaker is reset.

Installation

- OF, SD functions: a single type of contact provides all these different indication functions, depending on where it is inserted in the device. The contacts clip into slots behind the front cover of the circuit breaker.

Electrical characteristics of auxiliary contacts

Contacts	Standard				Low level					
Types of contacts	All				OF, SD					
Rated thermal current (A)	6				5					
Minimum load	100 mA at 24 V DC				1 mA at 4 V DC					
Utilisation cat. (IEC 60947-5-1)	AC12	AC15	DC12	DC14	AC12	AC15	DC12	DC14		
Operational current (A)	24 V	AC/DC	6	6	6	1	5	3	5	1
	48 V	AC/DC	6	6	2.5	0.2	5	3	2.5	0.2
	110 V	AC/DC	6	5	0.6	0.05	5	2.5	0.6	0.05
	220/240 V	AC	6	4	-	-	5	2	-	-
	250 V	DC	-	-	0.3	0.03	5	-	0.3	0.03
380/440 V	AC	6	2	-	-	5	1.5	-	-	

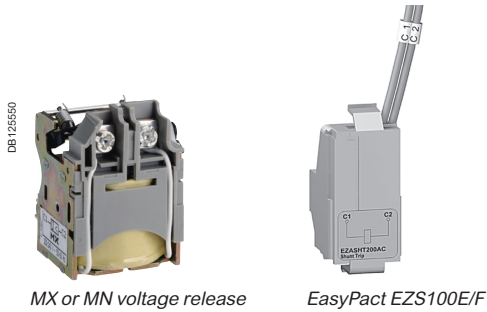

MX or MN voltage release

EasyPact EZS100E/F

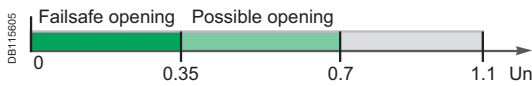

Opening conditions of the MN release.



Closing conditions of the MN release.

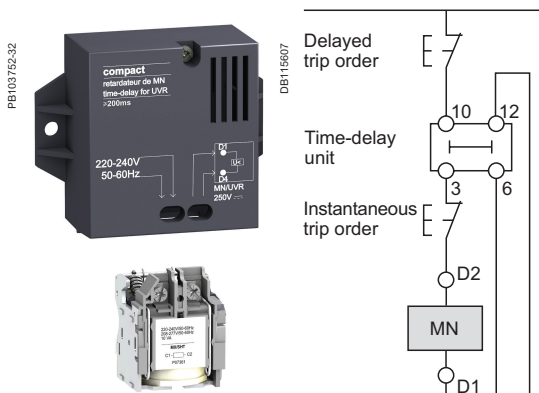

MN release with a time-delay unit.

Wiring diagram for emergency-off function with MN + time-delay unit.

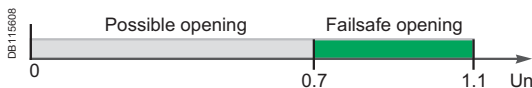

Opening conditions of the MX release.

MN undervoltage release

- This release trips the circuit breaker when the control voltage drops below a tripping threshold.
- The tripping threshold is between 0.35 and 0.7 times the rated voltage.
- Circuit breaker closing is possible only if the voltage exceeds 0.85 times the rated voltage.

Characteristics

Power supply	V AC	50/60 Hz: 24 - 48 - 100/130 - 200/240
		50 Hz: 380/415 60 Hz: 208/277
Operating threshold	V DC	12 - 24 - 30 - 48 - 60 - 125 - 250
	Opening	0.35 to 0.7 Un
	Closing	0.85 Un
Operating range		0.85 to 1.1 Un
Consumption (VA or W)		Pick-up: 10 - Hold: 5
Response time (ms)		50

Time-delay unit for an MN release

A time delay unit for the MN release eliminates the risk of nuisance tripping due to a transient voltage dip lasting ≤ 200 ms. For shorter micro-outages, a system of capacitors provides temporary supply to the MN at $U > 0.7$ to ensure non tripping. The correspondence between MN releases and time-delay units is shown below.

Power supply	Corresponding MN release
Unit with fixed delay 200 ms	
48 V AC	48 V DC
220 / 240 V AC	250 V DC
Unit with adjustable delay (0.5s, 0.9s, 1.5s, 3s)	
48 - 60 V AC/DC	48 V DC
100 - 130 V AC/DC	125 V DC
220 - 250 V AC/DC	250 V DC

MX shunt release

The MX release opens the circuit breaker via an impulse-type (≥ 20 ms) or maintained order.

Opening conditions

When the MX release is supplied, it automatically opens the circuit breaker. Opening is ensured for a voltage $U \geq 0.7 \times U_n$.

Characteristics

Power supply	V AC	50/60 Hz: 24 - 48 - 100/130 - 200/240
		50 Hz: 380/415 60 Hz: 208/277
Operating range	V DC	12 - 24 - 30 - 48 - 60 - 125 - 250
		0.7 to 1.1 Un
Consumption (VA or W)		Pick-up: 10
Response time (ms)		50

Circuit breaker control by MN or MX

When the circuit breaker has been tripped by an MN or MX release, it must be reset before it can be reclosed.

MN or MX tripping takes priority over manual closing.

In the presence of a standing trip order, closing of the contacts, even temporary, is not possible.

Connection using wires up to 1.5mm² to integrated terminal blocks.

Note: circuit breaker opening using an MN or MX release must be reserved for safety functions. This type of tripping increases wear on the opening mechanism. Repeated use reduces the mechanical endurance of the circuit breaker by 50%.

There are two types of rotary handle:

- direct rotary handle
- extended rotary handle.



EasyPact EZS with a rotary handle.

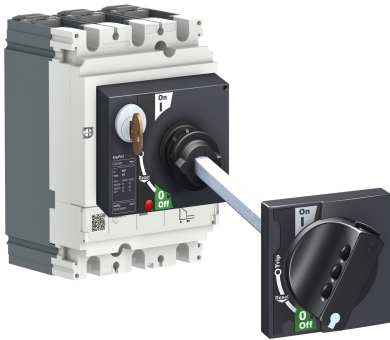

EasyPact EZS with an extended rotary handle installed at the back of a switchboard, with the keylock option and key.

Direct rotary handle

Standard handle

Degree of protection IP40, IK07.

The direct rotary handle maintains:

- visibility of and access to trip-unit settings.
- suitability for isolation.
- indication of the three positions O (OFF), I (ON) and tripped.
- access to the "push to trip" button.

Device locking

The rotary handle facilitates circuit-breaker locking.

- Padlocking:
 - standard situation, in the OFF position, using 1 to 3 padlocks, shackle diameter 5 to 8 mm, not supplied.

Extended rotary handle

Degree of protection IP54, IK08.

The extended rotary handle makes it possible to operate circuit breakers installed at the back of switchboards, from the switchboard front.

It maintains:

- visibility of and access to trip-unit settings.
- suitability for isolation.
- indication of the three positions O (OFF), I (ON) and tripped.

Device and door padlocking

Padlocking locks the circuit-breaker handle and disables door opening:

- standard situation, in the OFF position, using 1 to 3 padlocks, shackle diameter 5 to 8 mm, not supplied.

Parts of the extended rotary handle

- A unit that replaces the front cover of the circuit breaker (secured by screws).
- An assembly (handle and front plate) on the door that is always secured in the same position, whether the circuit breaker is installed vertically or horizontally.
- An extension shaft that must be adjusted to the distance. The min/max distance between the back of circuit breaker and door is:
 - 145...530 mm for EasyPact EZS100.
 - 185...600 mm for EasyPact EZS160/250.
 - 209...600 mm for EasyPact EZS 400/630.





Installation recommendations

<i>Presentation</i>	III
<i>Functions and characteristics</i>	A-1
Temperature derating	B-2
Installation in switchboards	B-3
Power supply and Safety clearances	B-3
Installation example	B-4
<i>Dimensions and connection</i>	C-1
<i>Technical data supplement</i>	D-1
<i>Catalogue numbers</i>	E-1



Ambient temperature

EasyPact EZS devices are equipped with fixed thermal-magnetic trip units.

- EasyPact EZS circuit breakers may be used between -25°C and +70°C.
- EasyPact EZS circuit breakers should be put into service under normal ambient operating temperature conditions. Exceptionally, the circuit breaker may be put into service when the ambient temperature is between -35°C and -25°C.
- the permissible storage-temperature range for EasyPact EZS circuit breakers in the original packing is -35°C to +85°C.

To determine tripping times using time/current curves, use I_r values corresponding to the thermal setting on the device, corrected as indicated in the tables below.

EZS100

Rated current (A)	Temperature						
	40°C	45°C	50°C	55°C	60°C	65°C	70°C
16	16.7	16.3	16	15.7	15.6	15.1	14.7
20	20.4	20.2	20	19.7	19.2	18.9	18.5
25	25.7	25.3	25	24.7	24.5	24.3	24.0
32	33.5	32.7	32	31.4	31.0	30.4	29.9
40	40.9	40.4	40	39.5	38.0	37.6	37.1
50	52.1	51.0	50	49.3	48.1	47.3	46.6
63	64.9	63.9	63	62.0	60.4	59.4	58.5
80	82.2	81.1	80	78.6	77.3	76.7	76.1
100	103.0	101.0	100	99.0	94.0	94.0	93.0

EZS160~630

Rated current (A)	Temperature						
	40°C	45°C	50°C	55°C	60°C	65°C	70°C
100	100	97.0	95.0	92.0	89.0	86.0	83.0
125	125	122.0	119.0	116.0	113.0	109.0	106.0
140	140	135.5	130.9	126.1	121.2	116.0	110.6
160	160	156.0	152.0	148.0	144.0	140.0	136.0
180	180	173.2	166.2	158.8	151.0	142.9	134.2
200	200	195.0	190.0	185.0	180.0	175.0	170.0
225	225	216.9	208.6	199.9	190.7	181.2	171.1
250	250	244.0	238.0	231.0	225.0	219.0	213.0
315	315	307.6	300.0	292.1	284.1	275.9	267.3
350	350	339.5	328.8	317.6	306.1	294.1	281.5
400	400	390.0	379.3	368.5	357.3	345.8	334.0
500	500	489.6	479.0	468.0	457.0	445.4	433.6
600	600	587.0	574.0	560.6	547.0	532.7	518.0

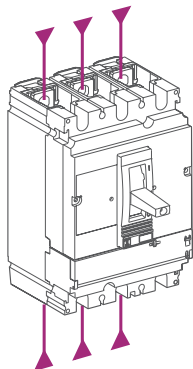

Power supply from the top or bottom

EZS circuit breakers can be supplied from either the top or the bottom without any reduction in performance. This capability facilitates connection when installed in a switchboard.

All connection and insulation accessories can be used on circuit breakers supplied either from the top or bottom.

General rules

When installing a circuit breaker, minimum distances (safety clearances) must be maintained between the device and panels, bars and other protection devices installed nearby. These distances, which depend on the ultimate breaking capacity, are defined by tests carried out in accordance with standard IEC 60947-2.

If installation conformity is not checked by type tests, it is also necessary to:

- use insulated bars for circuit-breaker connections
- segregate the busbars using insulating screens.

For EZS100 to 630 devices, terminal shields and interphase barriers are recommended and may be mandatory depending on the operating voltage of the device and type of installation (fixed, withdrawable, etc.).

Power connections

The table below indicates the rules to be respected for EZS100 to 630 devices to ensure the insulation of live parts for fixed devices.

EZS100 to 630: rules to be respected to ensure the insulation of live parts

Type of connection		Fixed, front connection			Fixed, rear connection	
Possible, recommended or mandatory accessories:		No insulating accessory	Interphase barriers	Long terminal shields ⁽¹⁾	Short terminal shields	
With:						
operating voltage	type of conductor					
≤ 440 V	Insulated bars		Possible	Possible	Possible	Recommended
	Extension terminals Cables + crimp lugs		No	Mandatory (supplied)	Possible (instead of ph. barriers)	Recommended
	Bare cables + connectors		Possible for EZS100 to 250	Possible for EZS100 to 250	Possible for EZS100 to 250	Recommended
		No	Mandatory (supplied)	Possible (instead of ph. barriers)		

(1) Long terminal shields provide a degree of protection of IP40 (ingress) and IK07 (mechanical impact).

Safety clearance

Minimum distance between two adjacent circuit breakers

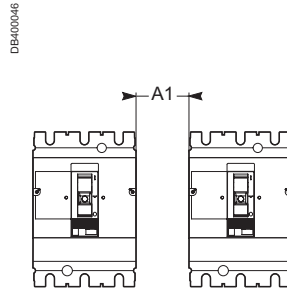

Minimum distance between circuit breaker and front or rear panels

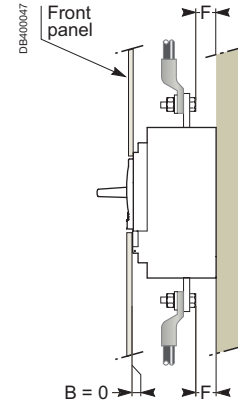

Bare or painted sheet metal

Note: if $F < 8$ mm: an insulating screen or long terminal shield is mandatory.

Minimum distance between circuit breaker and top, bottom or side panels

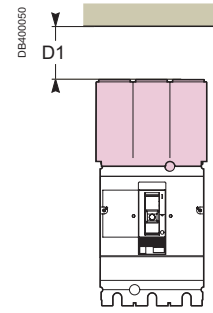
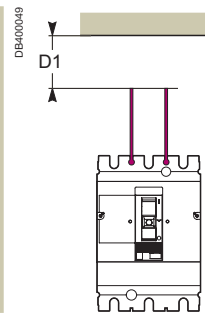
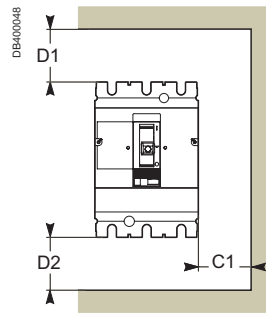

Devices without accessories.

Devices with interphase barriers or long terminal shields.

Minimum safety clearances for EZS100 to 630

Dimensions (mm) circuit breaker	Insulation, insulated bars or painted sheet metal			Bare sheet metal			
	C1	D1	D2	C1	D1	D2	A1
EZS100-250 $U \leq 440V$	0	30	30	5	35	35	0
EZS400-630 $U \leq 440V$	0	30	30	5	60	60	0

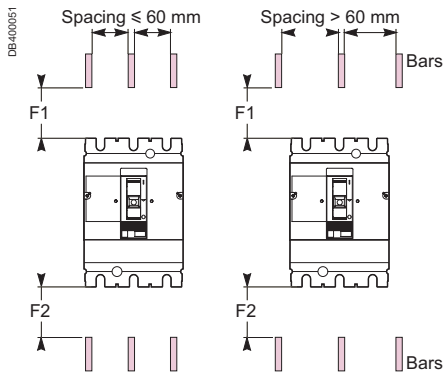

Clearances with respect to live bare busbars

Minimum clearances for EZS100 to 630

Operating voltage	Clearances with respect to live bare busbars			
	spacing \leq 60 mm		spacing $>$ 60 mm	
	F1	F2	F1	F2
U < 440 V	350	350	80	80
U = 440 V	350	350	120	120

These clearances can be reduced for special installations as long as the configuration is checked by tests.



Dimensions and connection

<i>Presentation</i>	III
<i>Functions and characteristics</i>	A-1
<i>Installation recommendations</i>	B-1
Dimensions and mounting	C-2
EasyPact EZS100	C-2
Rotary handle for EasyPact EZS100	C-5
EasyPact EZS160 - 630	C-6
Direct rotary handle for EasyPact EZS160 - 630	C-7
Extended rotary handle for EasyPact EZS160 - 630	C-8
Front-panel cutouts	C-9
EasyPact EZS160-630	C-9
Power connections	C-10
EasyPact EZS100	C-10
EasyPact EZS160-630	C-11
Connection of insulated bars or cables with lugs to EasyPact EZS160 - 630	C-13
<i>Technical data supplement</i>	D-1
<i>Catalogue numbers</i>	E-1

Dimensions

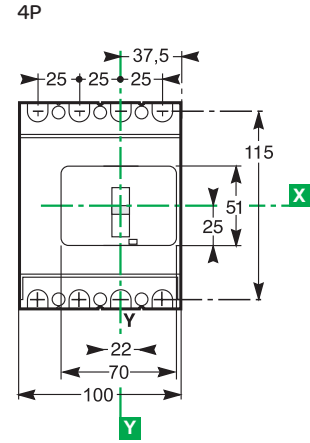
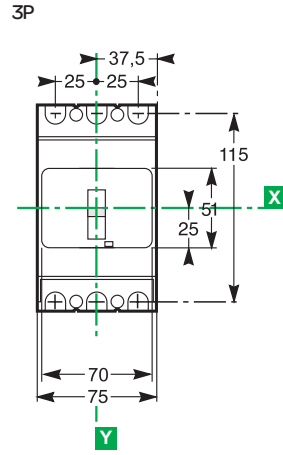
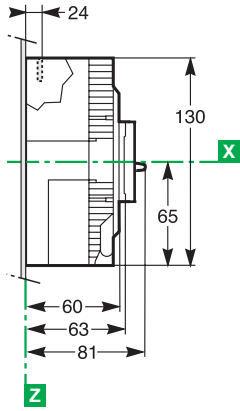

Backplate mounting

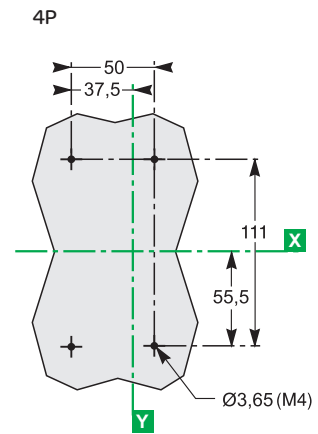
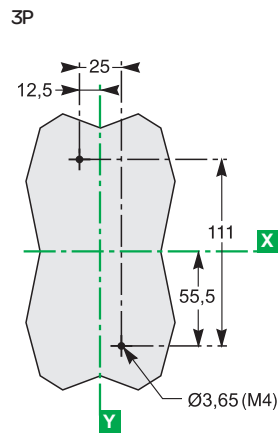

DIN rail mounting

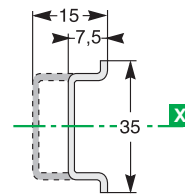
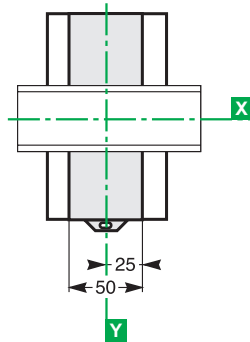
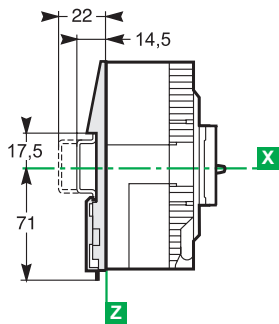

Front panel cutout

3P / 4P

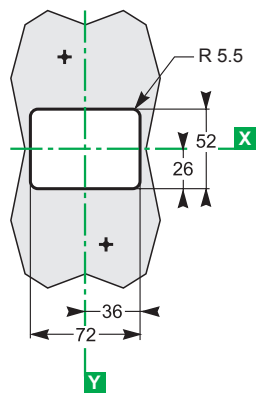
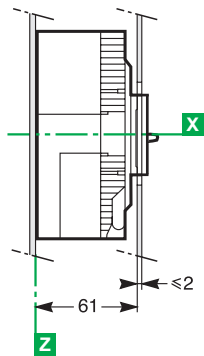

Terminal shield

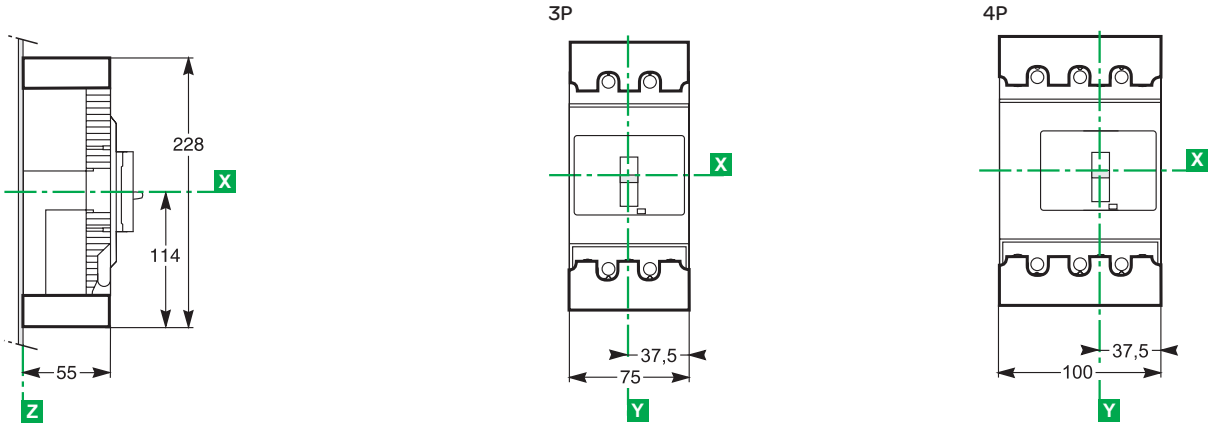

Interphase barrier

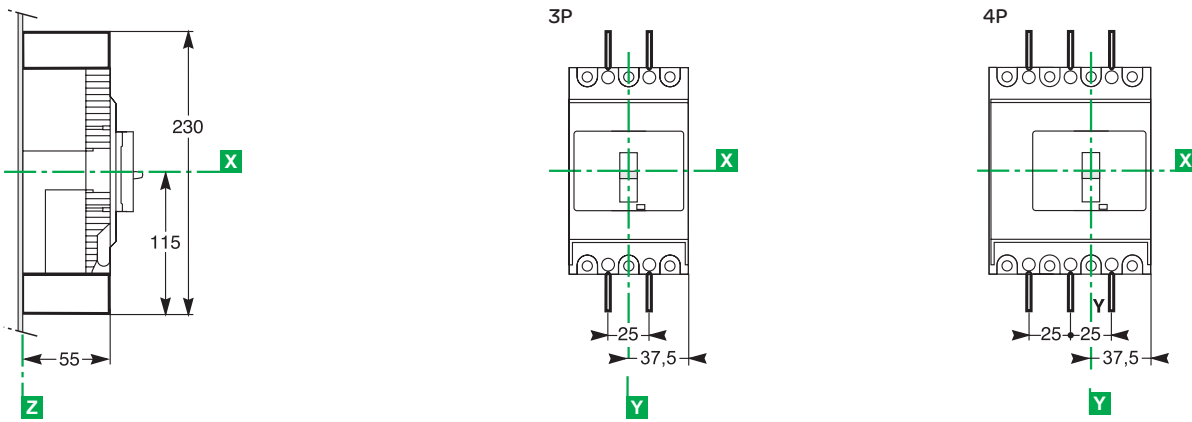

Direct rotary handle

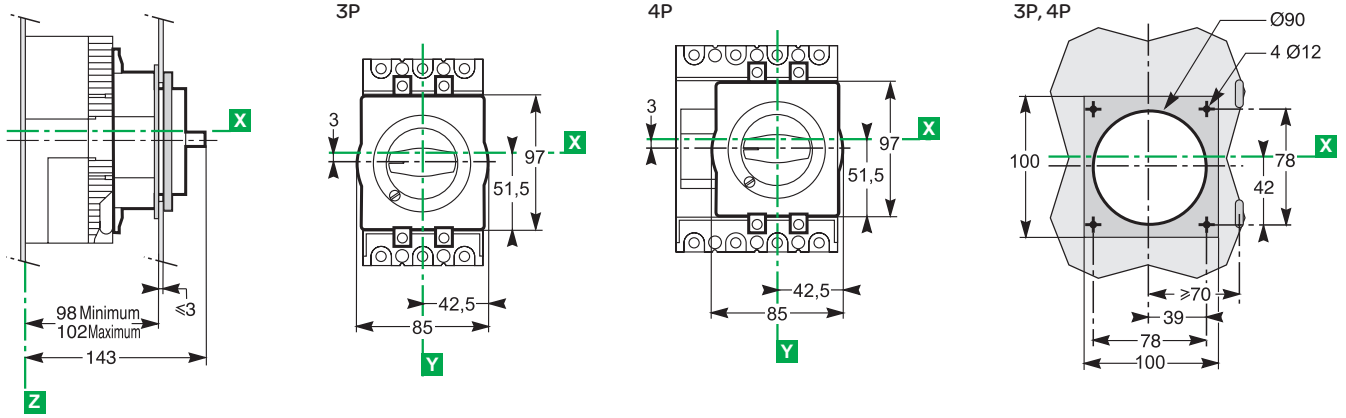

Extended rotary handle

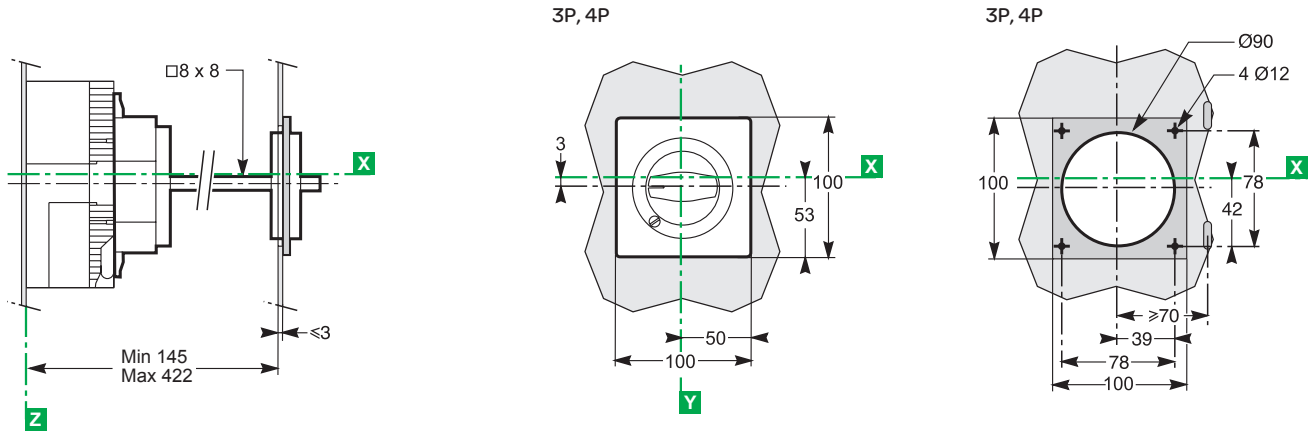

Dimensions 3P 4P

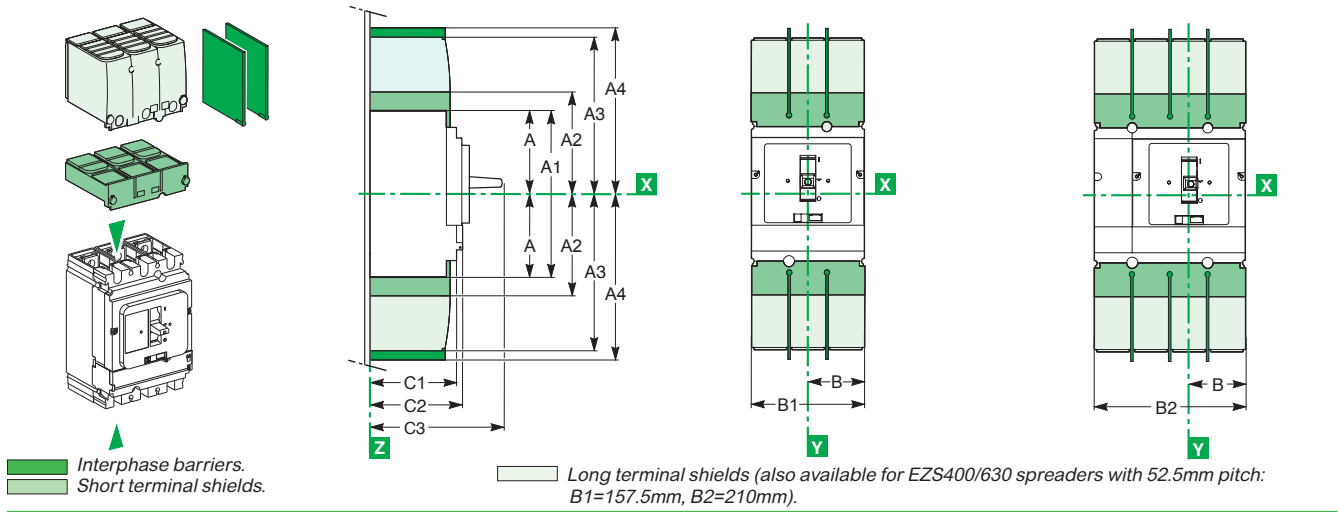

Mounting EZS160-250 EZS 400/630 EZS160-630

On backplate 3P 3P 4P

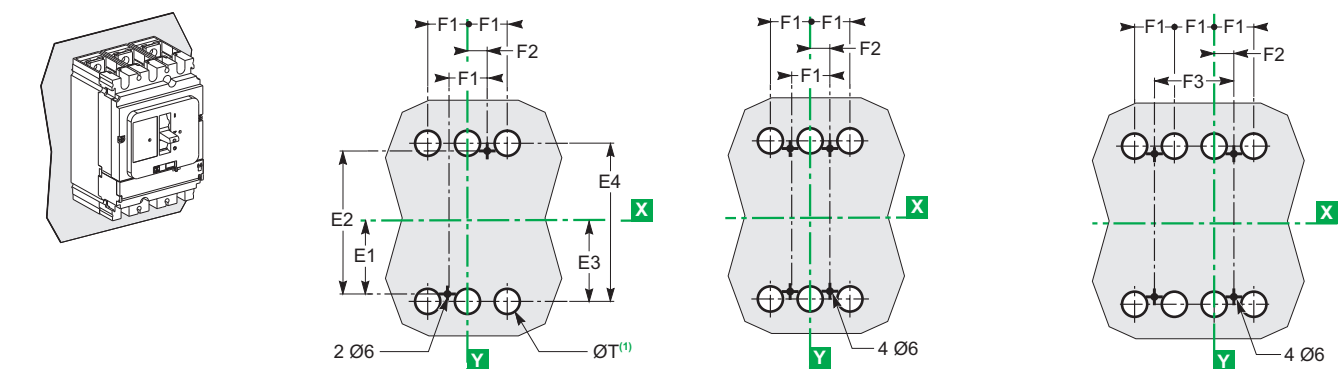

On rails 3P 3P 4P

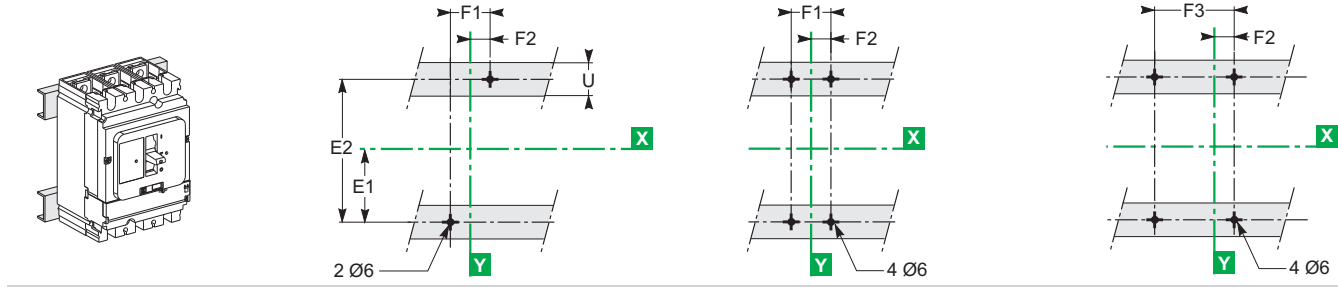

On DIN rail with adaptor plate (EZS160/250)



Type	A	A1	A2	A3	A4	B	B1	B2	C1	C2	C3	E1	
EZS160/250	80.5	161	94	145	178.5	52.5	105	140	81	86	111 ⁽¹⁾	62.5	
EZS400/630	127.5	255	142.5	200	237	70	140	185	95.5	110	168	100	
Type	E2	E3	E4	F1	F2	F3	G1	G2	G3	G4	G5	ØT	U
EZS160/250	125	70	140	35	17.5	70	95	75	13.5	23	17.5	24	≤ 32
EZS400/630	200	113.5	227	45	22.5	90	-	-	-	-	-	32	≤ 35

(1) C3=126mm, for EasyPact EZS225-250 installed with an extended rotary handle.

Dimensions **3P** **4P**

Fixed circuit breaker

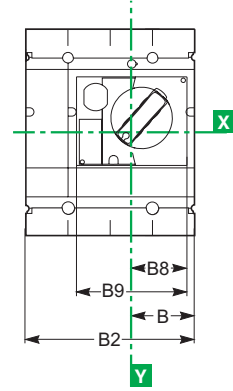
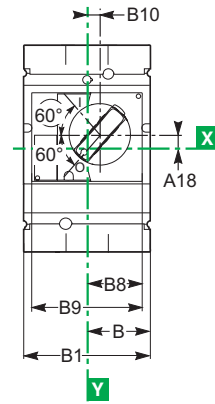
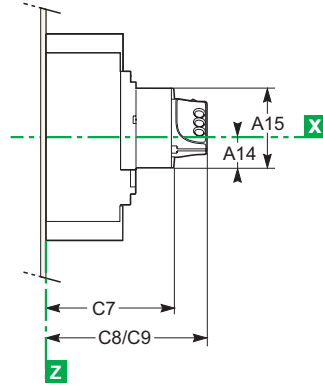
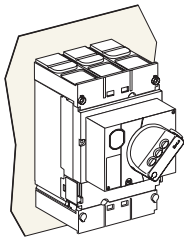

C8: without keylock
C9: with keylock

Type	A14	A15	A18	B8	B9	B10	C7	C8	C9
EZS160/250	27.5	73	9	45.5	91	9.25	121	155	164
EZS400/630	40	123	24.6	61.5	123	5	145	179	188

Dimensions

Fixed circuit breakers

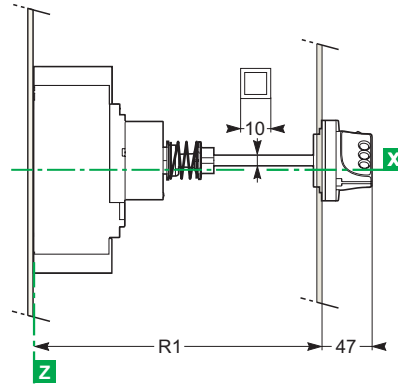
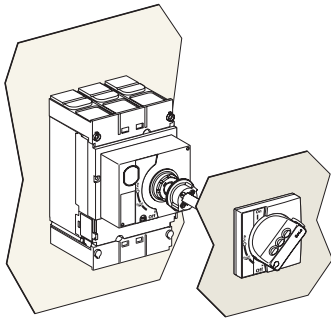

Cutout for shaft (mm)

Type	R1
EZS160/250	min. 171 max. 600
EZS400/630	min. 195 max. 600

Dimensions and front-panel cutout

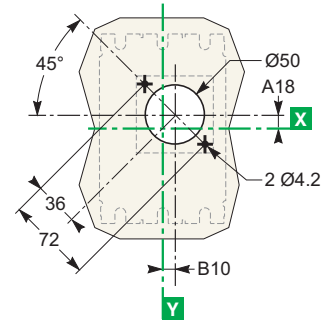
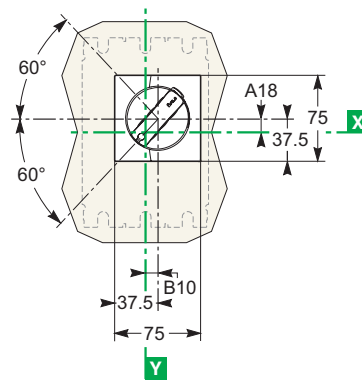

Type	A18	B10
EZS160/250	9	9.25
EZS400/630	24.6	5

Bare sheet metal

EZS160/250

EZS400/630

For toggle with access to trip unit

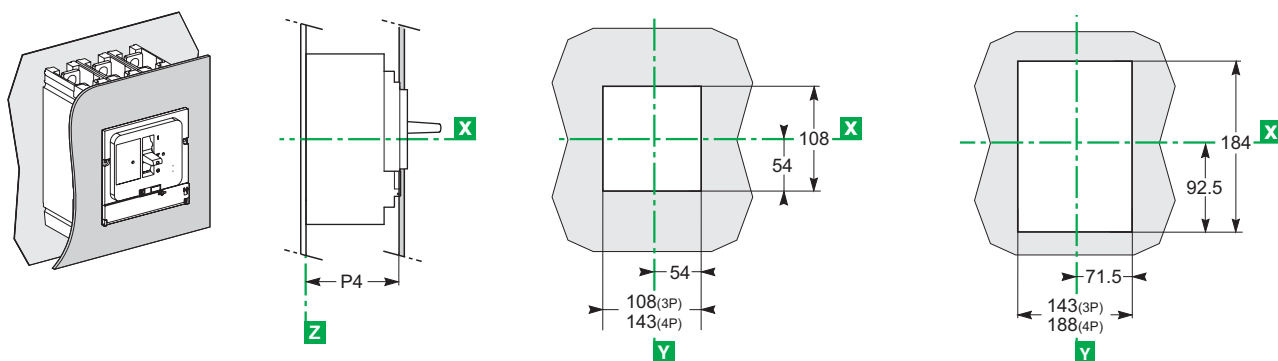

Type	P4
EZS160/250	83
EZS400/630	107



Spreader

Spreaders

Increase the pitch of the circuit breaker terminals:
 ■ EZS100 from 25 mm to 35 mm.

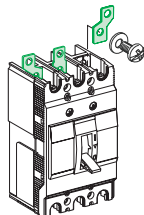

Designation	Cat. no.
	EZS100
Spreaders for 3-pole breaker (set of 3)	EZASPDR3P
Spreaders for 4-pole breaker (set of 4)	EZASPDR4P



Phase barriers for EZS100

Phase barriers

- Safety accessories for maximum insulation at the power connection points.
- Usable with all other connection accessories, except terminal shields.
- Each breaker is delivered with a set of phase barriers (2 for 3 poles and 3 for 4 poles breaker).
- Additional set of phase barriers available for insulation between outgoing or between 2 side by side-mounted breakers.

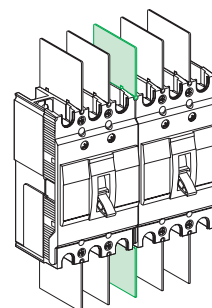
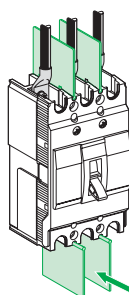

Designation	Cat. no.
	EZS100
Phase barriers for 60 mm depth (set of 2)	EZAFASB2

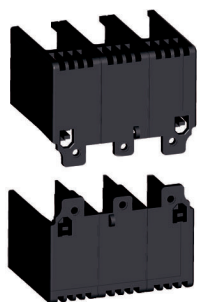

Terminal shield for EZS100

Terminal shields

- Insulating accessory used for protection against direct contacts with power circuit connections. It provides a degree of protection of IP20 and mechanical resistance of IK07.
- The long terminal shield is used with front cable or isolated busbar connections.
- Designed for 3-pole EZS100.

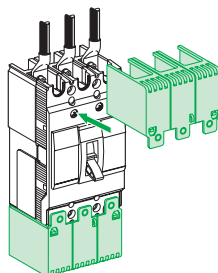

Designation	Cat. no.
	EZS100
Terminal shield 3P, 60 mm depth (set of 2)	EZATSHD3P
Terminal shield 4P, 60 mm depth (set of 2)	EZATSHD4P

Connection locations

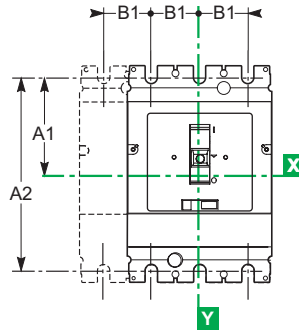
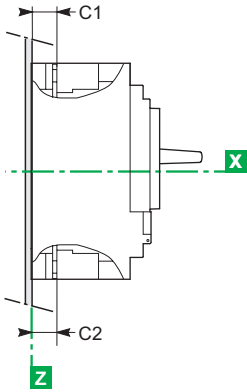

Type	A1	A2	B1	C1	C2
EZS160	70	140	35	19.5	19.5
EZS250	70	140	35	21.5	19.5
EZS400-630	113.5	227	45	26	26

Front connections without accessories

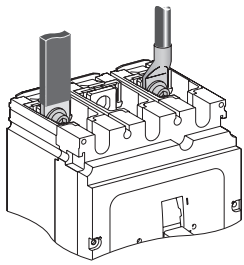

EZS160/250

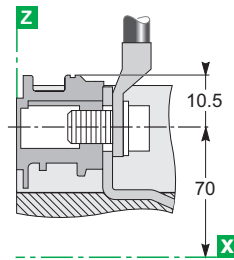

Cables with lugs/bars

EZS400/630

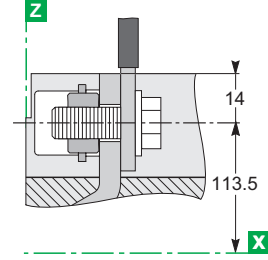

Bars/cables with lugs

Connection with accessories

Long and short rear connectors

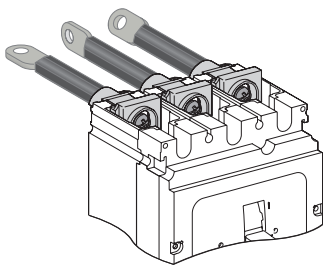

EZS160/250

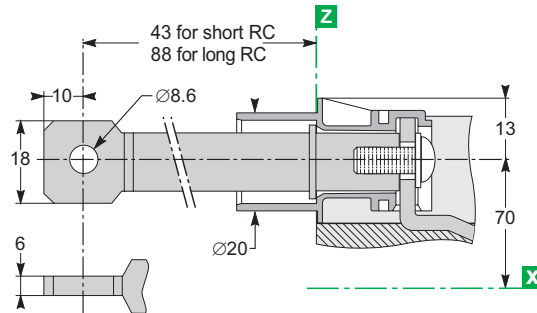

EZS400/630

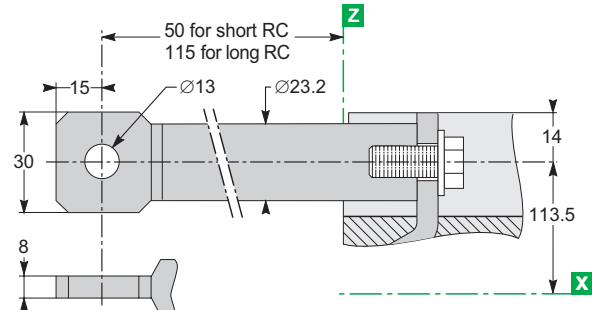

Connection with accessories (cont.)

Spreaders

3P

4P

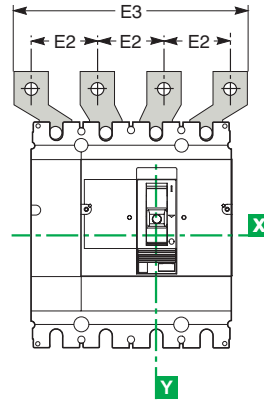
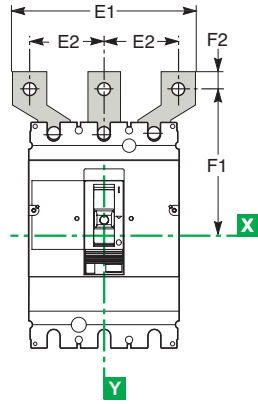
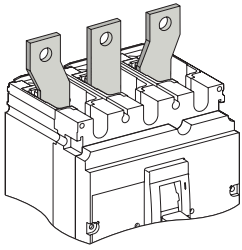

EZS160/250

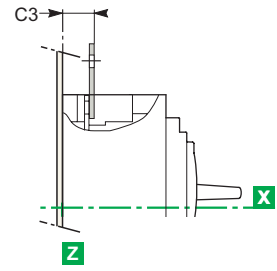

EZS400/630

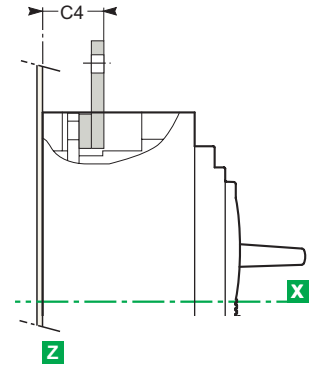

Type	C3	C4	E1	E2	E3	F1	F2
EZS160	23.5	-	114	45	159	100	11
EZS250	25.5	-	114	45	159	100	11
EZS400/630	-	44	135 170	52.5 70	187.5 240	152.5 166	15

Dimensions and connection

Power connections

Connection of insulated bars or cables with lugs to **EasyPact EZS160 - 630**

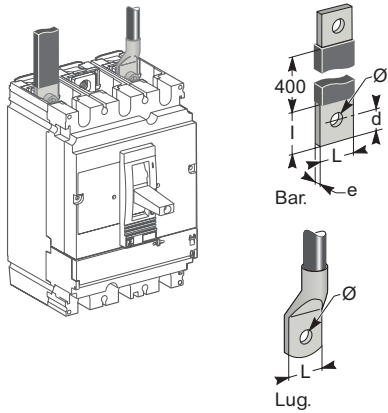

Accessories for EZS160/250

Spreaders:
separate parts



Tinned copper

Accessories for EZS400/630

Spreaders made up of separate parts for 52.5 and 70 mm pitch

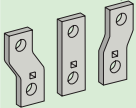

Tinned copper

Direct connection to EZS160 - 630

Dimensions	EZS160/250	EZS400/630
Bars		
L (mm)	≤ 25	≤ 32
l (mm)	d + 10	d + 15
d (mm)	≤ 10	≤ 15
e (mm)	≤ 6	3 ≤ e ≤ 10
Ø (mm)	8.5	10.5
Lugs		
L (mm)	≤ 25	≤ 32
Ø (mm)	8.5	10.5
Torque (Nm) ⁽¹⁾	15	50
Torque (Nm) ⁽²⁾	5/5	20/11

(1) Tightening torque on the circuit breaker for lugs or bars.

(2) Tightening torque on fixed devices for rear connectors.

Connection with accessories to EZS160/250 (IEC 228)

Pole pitch	
Without spreaders	35 mm
With spreaders	45 mm

Dimensions	With spreaders or terminal extensions EZS160 - 250
------------	-------------------------------------------------------

Bars	L (mm)	≤ 25
	l (mm)	20 ≤ l ≤ 25
	d (mm)	≤ 10
	e (mm)	≤ 6
	Ø (mm)	8.5
Lugs	L (mm)	≤ 25
	Ø (mm)	8.5
Torque (Nm) ⁽¹⁾		15

(1) Tightening torque on the circuit breaker for spreaders or terminal extensions.

Spreaders are supplied with flexible interphase barriers.

Connection with accessories to EZS400/630 (IEC 228)

Pole pitch	
Without spreaders	45 mm
With spreaders	52.5 or 70 mm

Dimensions	With spreaders
------------	----------------

Bars	L (mm)	≤ 40
	l (mm)	d + 15
	d (mm)	≤ 20
	e (mm)	3 ≤ e ≤ 10
	Ø (mm)	12.5
Lugs	L (mm)	≤ 40
	Ø (mm)	12.5
Torque (Nm) ⁽¹⁾		50

(1) Tightening torque on the circuit breaker for spreaders or terminal extensions.

Spreaders and right-angle, 45° and edgewise terminal extensions are supplied with flexible interphase barriers.

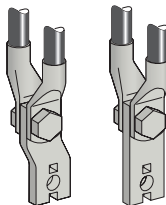

Mounting detail: 2 cables with lugs.

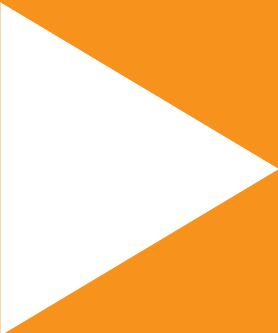

Technical data supplement

<i>Presentation</i>	III
<i>Functions and characteristics</i>	A-1
<i>Installation recommendations</i>	B-1
<i>Dimensions and connection</i>	C-1
Tripping Curve	D-2
Protection of distribution systems	D-2
<i>Catalogue numbers</i>	E-1

16A

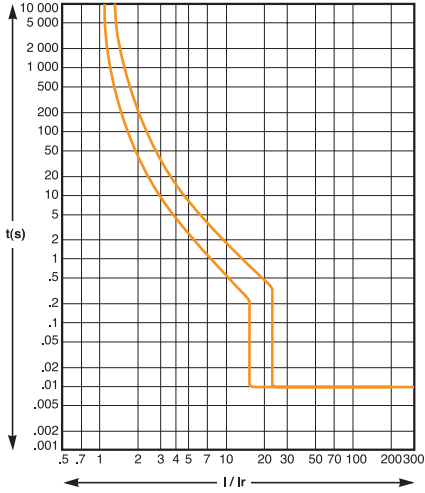

20A

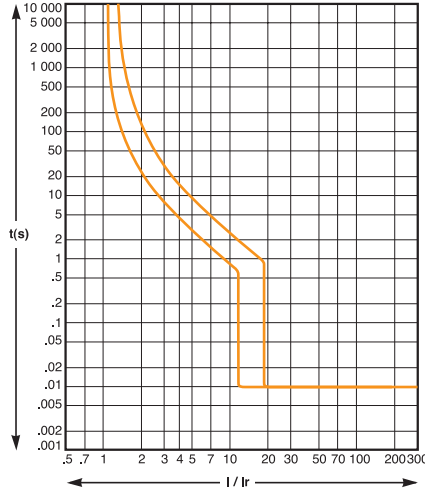

25A

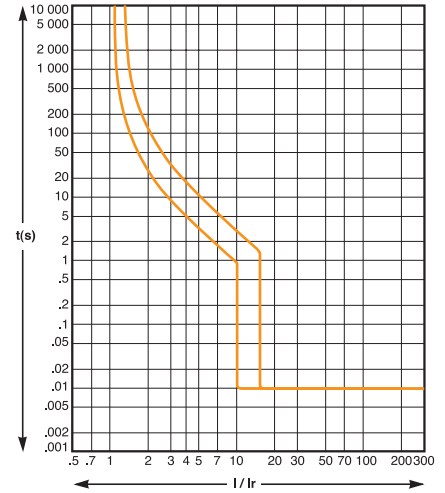

32A

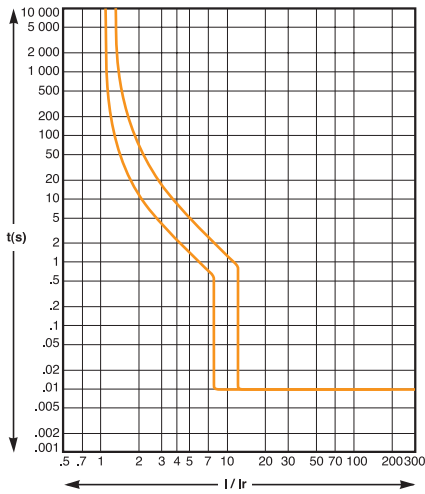

40A

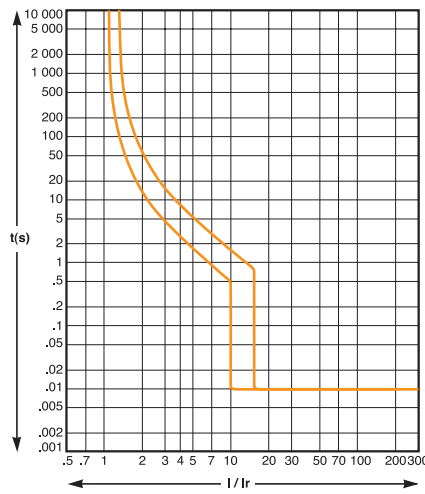

50A

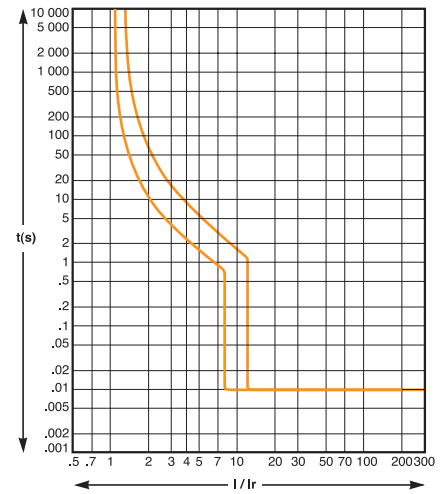

63A

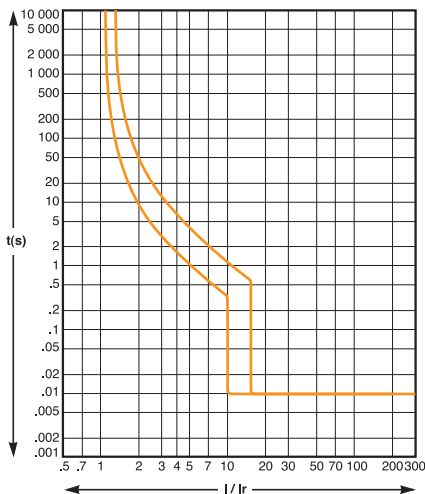

80A

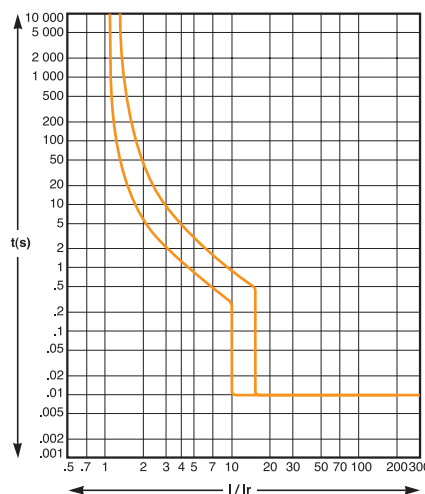

100A

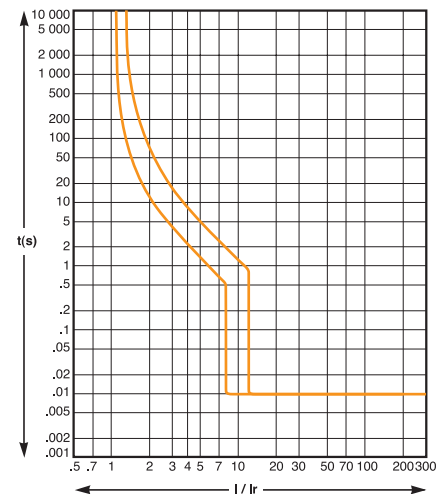

TM magnetic trip units

TM125D/160D

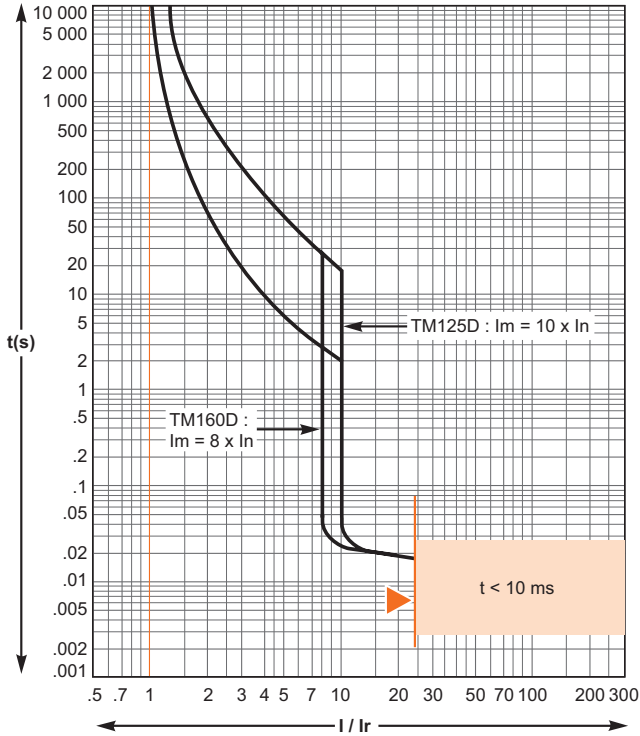

TM200D/250D

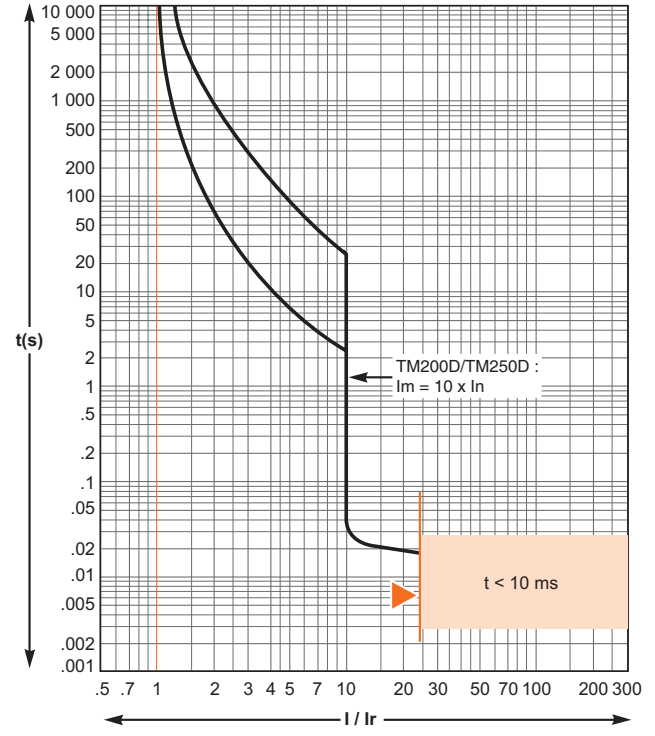

TM320D/400D

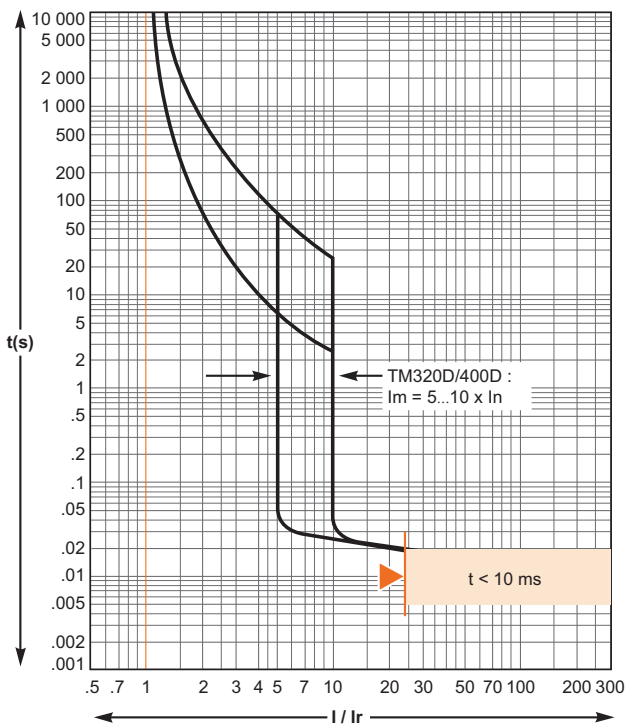

TM500D

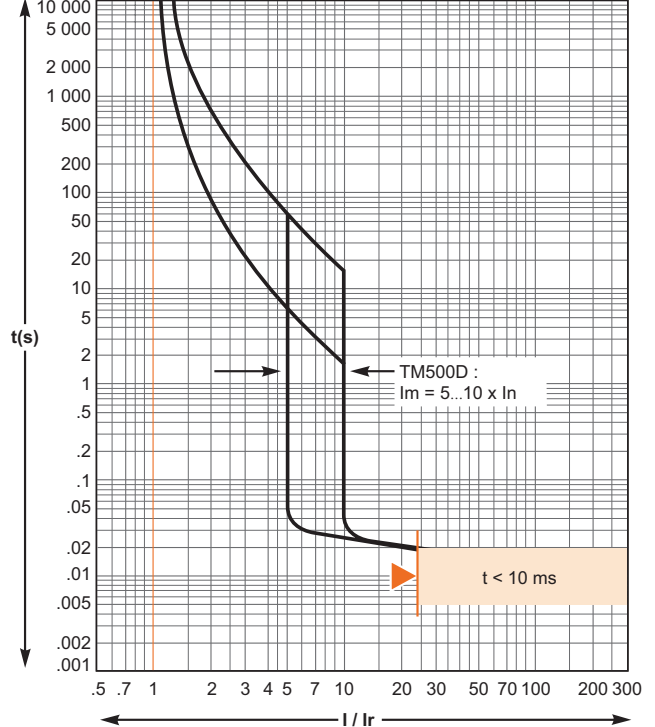

Reflex tripping.

TM magnetic trip units

TM600D

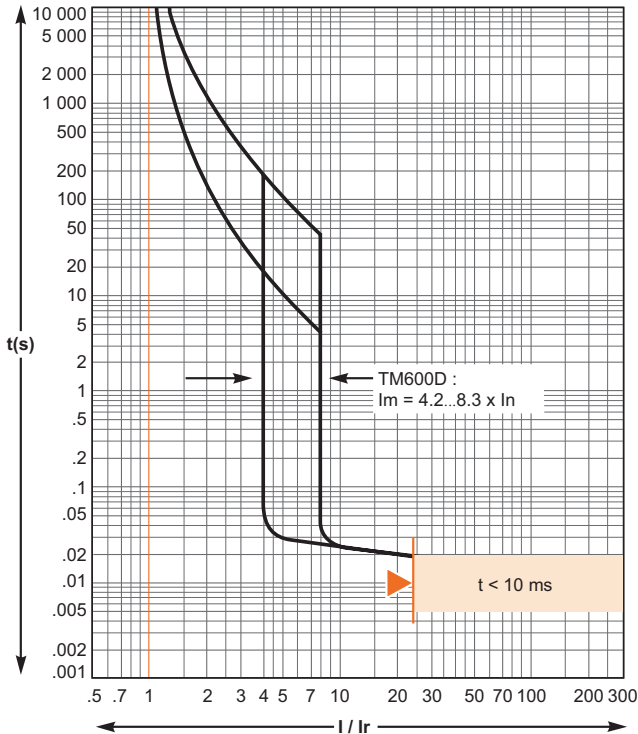

Reflex tripping.





Catalogue numbers

<i>Presentation</i>	<i>III</i>
<i>Functions and characteristics</i>	<i>A-1</i>
<i>Installation recommendations</i>	<i>B-1</i>
<i>Dimensions and connection</i>	<i>C-1</i>
<i>Technical data supplement</i>	<i>D-1</i>
EZS100E/F	E-2
Circuit breaker	E-2
Accessories	E-3
EZS160/250E/F	E-5
Circuit breaker	E-5
Accessories	E-6
EZS400/630F/N	E-8
Circuit breaker	E-8
Accessories	E-9

Commercial references

EasyPact EZS100

With TM-D thermal-magnetic trip unit

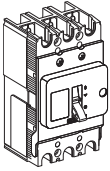

EasyPact EZS100E (25 kA at 380/415 V)



Rating	3P3d	4P3d
TM16D	EZS100E3016	EZS100E4016
TM20D	EZS100E3020	EZS100E4020
TM25D	EZS100E3025	EZS100E4025
TM32D	EZS100E3032	EZS100E4032
TM40D	EZS100E3040	EZS100E4040
TM50D	EZS100E3050	EZS100E4050
TM63D	EZS100E3063	EZS100E4063
TM80D	EZS100E3080	EZS100E4080
TM100D	EZS100E3100	EZS100E4100

EasyPact EZS100F (30 kA at 380/415 V)

Rating	3P3d	4P3d
TM16D	EZS100F3016	EZS100F4016
TM20D	EZS100F3020	EZS100F4020
TM25D	EZS100F3025	EZS100F4025
TM32D	EZS100F3032	EZS100F4032
TM40D	EZS100F3040	EZS100F4040
TM50D	EZS100F3050	EZS100F4050
TM63D	EZS100F3063	EZS100F4063
TM80D	EZS100F3080	EZS100F4080
TM100D	EZS100F3100	EZS100F4100

Connection accessories

Cable lugs

	≤ 50A	Cables from 2.5 to 16 mm ²	Set of 2	EZALUG0502
			Set of 3	EZALUG0503
	> 50A	Cables from 10 to 50 mm ²	Set of 2	EZALUG1002
			Set of 3	EZALUG1003

Spreaders

	Spreaders for 3P breaker		Set of 2	EZASPDR3P
	Spreaders for 4P breaker		Set of 3	EZASPDR4P

Terminal shields

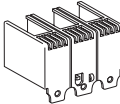
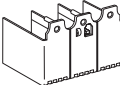

	Spreaders for 3P breaker		Set of 2	EZATSHD3P
	Spreaders for 4P breaker		Set of 3	EZATSHD4P
				

Phase barriers

	Phase barriers		Set of 2	EZAFASB2
-------------------------------------------------------------------------------------	----------------	--	----------	----------

Electrical auxiliaries

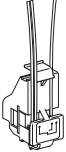
Indication contacts

	Auxiliary switch (AX)			EZAUX10
	Alarm switch (AL)			EZAUX01
	Auxiliary switch + alarm switch (AX + AL)			EZAUX11

Electrical auxiliaries (cont.)

Voltage releases

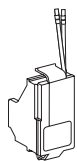

Shunt trip (SHT)

	Voltage	MX/SHT
AC	100 - 130V	EZASHT100AC
	200 - 277V	EZASHT200AC

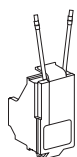

Undervoltage release (UVR)

	Voltage	MN/UVR
AC	200 - 240V	EZAUVR200AC

Rotary handles

Direct rotary handle (for 3/4P breaker)



Direct rotary handle (black)	EZAROTDS
------------------------------	----------

Extended rotary handle (for 3/4P breaker)

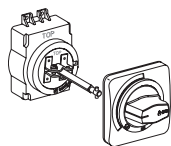

Extended rotary handle (black)	EZAROTE
--------------------------------	---------

Commercial references

EasyPact EZS160

With TM-D thermal-magnetic trip unit

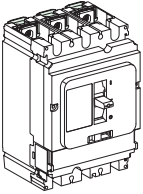

EasyPact EZS160E (25 kA at 380/415 V)

Rating	3P3d	4P3d
TM100D	EZS160E3100	EZS160E4100
TM125D	EZS160E3125	EZS160E4125
TM160D	EZS160E3160	EZS160E4160

EasyPact EZS160F (36 kA at 380/415 V)

Rating	3P3d	4P3d
TM100D	EZS160F3100	EZS160F4100
TM125D	EZS160F3125	EZS160F4125
TM160D	EZS160F3160	EZS160F4160

EasyPact EZS250

With TM-D thermal-magnetic trip unit

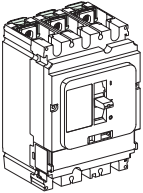

EasyPact EZS250E (25 kA at 380/415 V)

Rating	3P3d	4P3d
TM200D	EZS250E3200	EZS250E4200
TM225D	EZS250E3225	EZS250E4225
TM250D	EZS250E3250	EZS250E4250

EasyPact EZS250F (36 kA at 380/415 V)

Rating	3P3d	4P3d
TM200D	EZS250F3200	EZS250F4200
TM225D	EZS250F3225	EZS250F4225
TM250D	EZS250F3250	EZS250F4250

Connection accessories (Cu or Al)

Rear connections

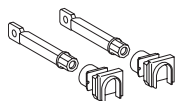

2 short			LV429235
2 long			LV429236

Bare cable connectors

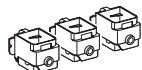

Steel connectors	1 x (1.5 to 95 mm ²) ; ≤ 160 A	Set of 3	LV429242
		Set of 4	LV429243

Terminal extensions



Spreaders from 35 to 45 mm pitch ⁽¹⁾	Set of 3	LV431563
	Set of 4	LV431564

Insulation accessories

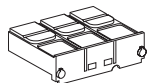

1 short terminal shield for breaker	3 P	LV429515
	4 P	LV429516

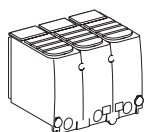

1 long terminal shield for breaker	3 P	LV429517
	4 P	LV429518

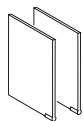

Interphase barriers for breaker	Set of 6	LV429329
---------------------------------	----------	----------

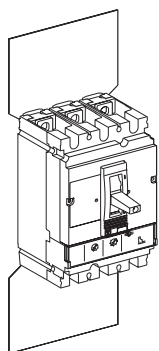

2 insulating screens for breaker (45 mm pitch)	3P	LV429330
	4P	LV429331

⁽¹⁾ Supplied with 2 or 3 interphase barriers.

Electrical auxiliaries

Auxiliary contacts (changeover)



OF or SD	29450
OF or SD low level	29452

Voltage releases



	Voltage	MX	MN
AC	110-130 V 50/60 Hz	LV429386	LV429406
	220-240 V 50/60 Hz and 208-277 V 60 Hz	LV429387	LV429407
DC	24 V	LV429390	LV429410

Rotary handles

Direct rotary handle

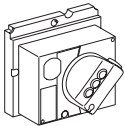

With black handle	LV429337
-------------------	----------

Extended rotary handle

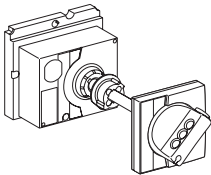

With black handle	LV429338
-------------------	----------

Commercial references

EasyPact EZS400

With TM-D thermal-magnetic trip unit

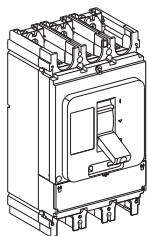

EasyPact EZS400F (36 kA at 380/415 V)

Rating	3P3d	4P3d
TM315D	EZS400F3315	EZS400F4315
TM350D	EZS400F3350	EZS400F4350
TM400D	EZS400F3400	EZS400F4400

EasyPact EZS400N (50 kA at 380/415 V)

Rating	3P3d	4P3d
TM315D	EZS400N3315	EZS400N4315
TM350D	EZS400N3350	EZS400N4350
TM400D	EZS400N3400	EZS400N4400

EasyPact EZS630

With TM-D thermal-magnetic trip unit

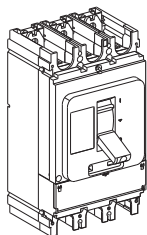

EasyPact EZS630F (36 kA at 380/415 V)

Rating	3P3d	4P3d
TM500D	EZS630F3500	EZS630F4500
TM600D	EZS630F3600	EZS630F4600

EasyPact EZS630N (50 kA at 380/415 V)

Rating	3P3d	4P3d
TM500D	EZS630N3500	EZS630N4500
TM600D	EZS630N3600	EZS630N4600

Connection accessories (Cu or Al)

Rear connections

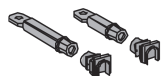

2 short	LV432475
2 long	LV432476

Cable connectors ⁽¹⁾



Aluminium connector 1x (35 to 300 mm ²)	Set of 3	LV432479
	Set of 4	LV432480

Terminal extension ⁽¹⁾



Spreaders	70 mm	3P	LV432492
		4P	LV432493

Insulation accessories



Short terminal shield, 45 mm (1 piece)	3P	LV432591
	4P	LV432592



Long terminal shield, 45 mm (1 piece)	3P	LV432593
	4P	LV432594



Interphase barriers	Set of 6	LV432570
---------------------	----------	----------

⁽¹⁾ supplied with 2 or 3 interphase barriers.

Electrical auxiliaries

Auxiliary contacts (changeover)



OF or SD	29450
OF or SD low level	29452

Voltage releases



	Voltage	MX	MN
AC	110-130 V 50/60 Hz	LV429386	LV429406
	220-240 V 50/60 Hz and 208-277 V 60 Hz	LV429387	LV429407
DC	24 V	LV429390	LV429410

Rotary handle

Direct rotary handle

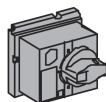

Standard black handle	LV432597
-----------------------	----------

Extended rotary handle

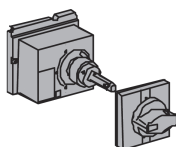

Standard extended rotary handle	LV432598
---------------------------------	----------

Life Is On

Schneider
Electric

Schneider Electric Industries SAS

35, rue Joseph Monier
CS 30323
92506 Rueil Malmaison Cedex
France

RCS Nanterre 954 503 439
Capital social 928 298 512 €
www.se.com

Sep-2020

© 2020 - Schneider Electric. All Rights Reserved.
All trademarks are owned by Schneider Electric Industries SAS or its affiliated companies.
Document reference LVED215011EN

This document has been
printed on recycled paper

