

# RMB300

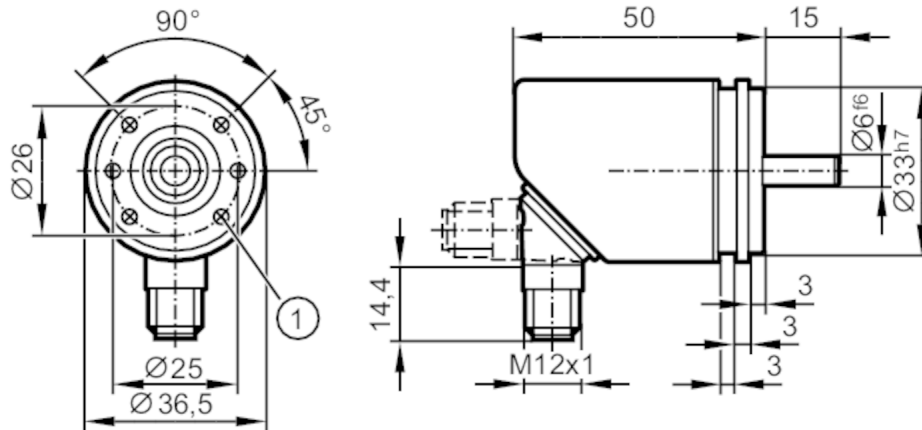

## Absolute multiturn encoder with solid shaft

MULTITURN ENCODER STANDARD LINE



1 M3 x 0.5 Depth 6 mm



Product characteristics	
Resolution	65536 steps; 32768 revolutions; 31 bit
Communication interface	IO-Link
Shaft design	solid shaft
Shaft diameter [mm]	6
Application	
Function principle	absolute
Revolution type	multiturn
Electrical data	
Operating voltage [V]	18...30 DC; (to PELV)
Rated insulation voltage [V]	30
Current consumption [mA]	< 75
Protection class	III
Reverse polarity protection	yes
Max. power-on delay time [ms]	1000
Max. revolution electrical [U/min]	12000
Outputs	
Short-circuit protection	yes
Measuring/setting range	
Resolution	65536 steps; 32768 revolutions; 31 bit
Accuracy / deviations	
Accuracy [°]	0.1
Software / programming	
Parameter setting options	preset; Zero point; Direction of rotation; rotational speed

# RMB300



## Absolute multiturn encoder with solid shaft

MULTITURN ENCODER STANDARD LINE

Interfaces		
Communication interface	IO-Link	
Transmission type	COM3 (230,4 kBaud)	
IO-Link revision	1.1	
SDCI standard	IEC 61131-9 CDV	
Profiles	Identification and Diagnosis; Switching Signal Channel; Measurement Data Channel (high resolution)	
SIO mode	no	
Required master port class	A	
Min. process cycle time [ms]	2.3	
IO-Link process data (cyclical)	Function	bit length
	process value	96
	device status	4
	binary switching information	5
IO-Link functions (acyclical)	application specific tag; operating hours counter; internal temperature; switching cycles counter	
Supported DeviceIDs	Type of operation	DeviceID
	default	1064
Note	For further information please see the IODD PDF file at "Downloads"	
Operating conditions		
Ambient temperature [°C]	-40...85	
Storage temperature [°C]	-40...85	
Max. relative air humidity [%]	98; (Condensation not permissible)	
Protection	IP 65; (on the housing: IP 67; on the shaft: IP 64)	
Tests / approvals		
EMC	DIN EN 61000-4-2 ESD	4 kV CD
	DIN EN 61000-4-3 HF radiated	10 V/m
	DIN EN 61000-4-4 Burst	2 kV
	DIN EN 61000-4-6 HF conducted	10 V
Vibration resistance	DIN EN 60068-2-6	10 g / 10...1000 Hz half-sine
Shock resistance	DIN EN 60068-2-27	100 g 6 ms
Continuous shock resistance	DIN EN 60068-2-29	10 g / 16 ms half-sine
Vibration resistance		30 g (10...1000 Hz)
MTTF [years]	283	

# RMB300



## Absolute multiturn encoder with solid shaft

MULTITURN ENCODER STANDARD LINE

Mechanical data		
Weight	[g]	227.2
Dimensions	[mm]	Ø 36 / L = 65
Material		flange: aluminum; housing: stainless steel (1.4521 / 444)
Max. starting torque	[Nm]	1
Reference temperature torque	[°C]	20
Shaft design		solid shaft
Shaft diameter	[mm]	6
Shaft material		stainless steel
Max. shaft load axial (at the shaft end)	[N]	40
Max. shaft load radial (at the shaft end)	[N]	110
Fixing flange		servo flange

### Electrical connection - plug

Connector: 1 x M12; Moulded body: stainless steel (1.4401 / 316)

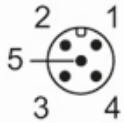

1	UB
2	SSC1.2 / IN
3	GND
4	IO-Link
5	n. c.