

Magnetically Coupled Rodless Cylinder



Upgraded version of space saving magnetically coupled rodless cylinder

Basic type Direct mount type
Series CY3B/CY3R

Series CY3B/CY3R

Improved durability

Improved bearing performance

A 70% longer wear ring length achieving an improvement in bearing performance compared to the CY1B.

Improved lubrication by using a soft wiper

A special resin soft wiper is installed on the dust seal to achieve a ideal lubrication on the external surface of the cylinder tube.

Direct mount type **Series CY3R**

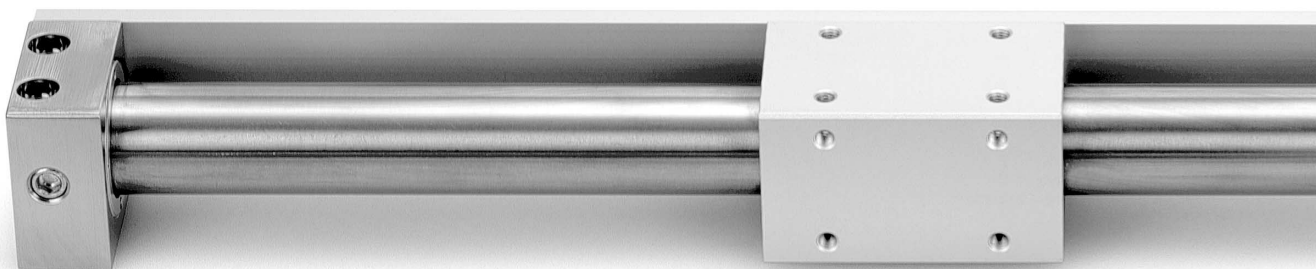

Basic type **Series CY3B**



NPT and G thread are standardized.

Variety of piping port thread expanded to 3 types
Cylinders with a bore ≥ 20 or larger, are now available with 3 types of piping port threads.

(Refer to "How to Order": CY3B series Page 7)
CY3R series Page 11)

Bore size (mm)	Thread type
15	M thread
20, 25, 32, 40	Rc thread
	NPT thread
	G thread

Mounting dimensions are identical with those of series CY1.

Series CY3B

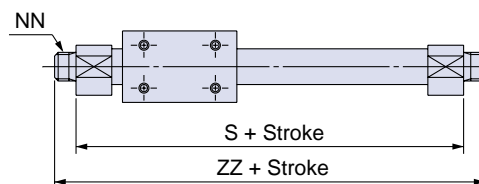

The mounting dimensions (in the drawing on the left) are identical with those of existing series CY1B/CY1R, allowing easy replacement.

Series CY3R

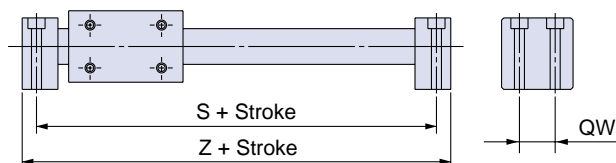

Upgraded version of saving magnetically rodless cylinder!

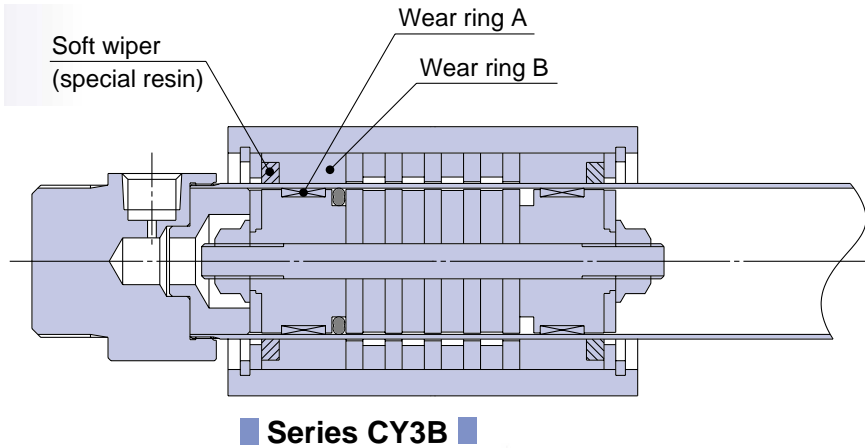

Reduction of sliding resistance

Minimum operating pressure reduced by 30%

By using a soft wiper the minimum operating pressure is reduced by 30%.

(comparing CY3B40 and CY1B40)

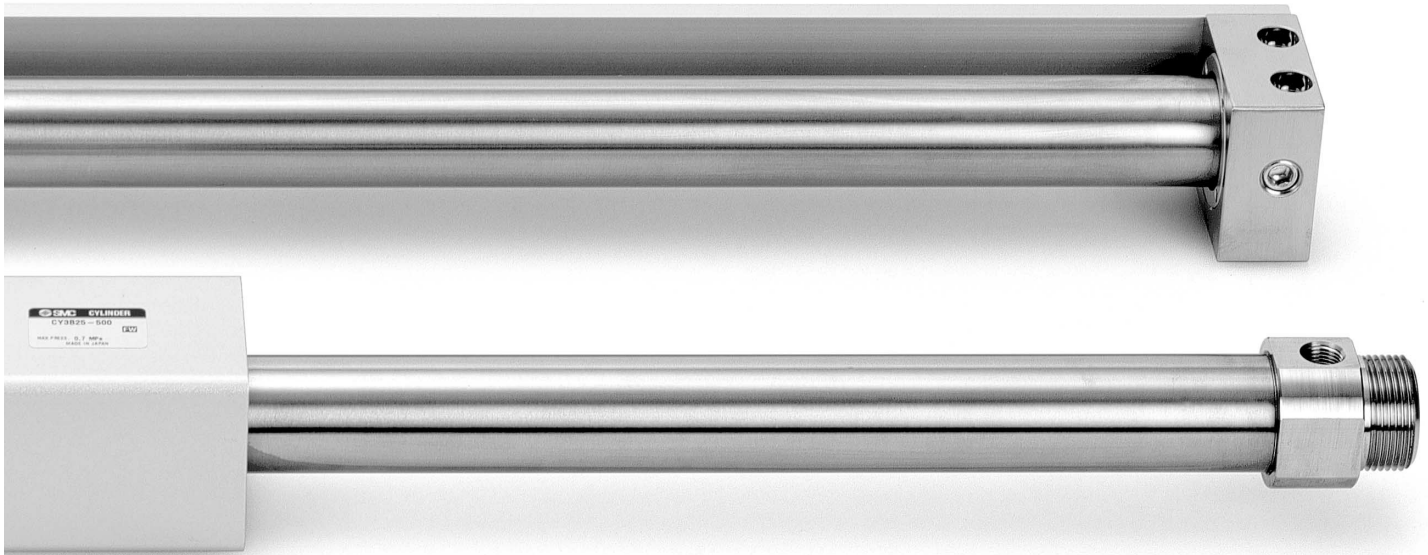



Series variations

Series	Bore size	Standard stroke (mm)											Individual made to order products					
		50	100	150	200	250	300	350	400	450	500	600	700	800	900	1000		
CY3B	ø15	●	●	●	●	●	●	●	●	●	●	●	●	●	●	●		
	ø20	●	●	●	●	●	●	●	●	●	●	●	●	●	●	●		
	ø25	●	●	●	●	●	●	●	●	●	●	●	●	●	●	●		
	ø32	●	●	●	●	●	●	●	●	●	●	●	●	●	●	●		
CY3R	ø40	●	●	●	●	●	●	●	●	●	●	●	●	●	●	●	●	
	ø15	●	●	●	●	●	●	●	●	●	●	●	●	●	●	●		
	ø20	●	●	●	●	●	●	●	●	●	●	●	●	●	●	●		
	ø25	●	●	●	●	●	●	●	●	●	●	●	●	●	●	●		
	ø32	●	●	●	●	●	●	●	●	●	●	●	●	●	●	●		
	ø40	●	●	●	●	●	●	●	●	●	●	●	●	●	●	●	●	

Note) The mark ● indicates the available combination of bore size and standard stroke.

Availability of made to order products varies with the series (CY3B/R) and the bore size. For more information please refer page 20.

Series CY3B/CY3R Model Selection Criteria

Model selection point	Recommended cylinder		
	Appearance	Features	
<ul style="list-style-type: none"> ●When used with many different types of guides. ●When a long stroke is necessary. 	Types with guide	<p>Series CY3B Size/ø15, ø20, ø25, ø32, ø40</p> 	<ul style="list-style-type: none"> · A long stroke is possible.
<ul style="list-style-type: none"> ●When used with many different types of guides. ●When auto switches are added to the basic type. ●When used without a guide for a light load. (Application Example 1) ●When space is very limited. 		<p>Series CY3R Size/ø15, ø20, ø25, ø32, ø40</p> 	<ul style="list-style-type: none"> · Cylinder can be directly mounted. · Auto switches can be mounted, and there is no lurching from cylinder. · Non-rotation mechanism is available within the allowable range. · Piping can be concentrated with the centralized piping type. · External dimensions are compact. · Mounting can be performed on the top body surface or on one side surface.

Application example

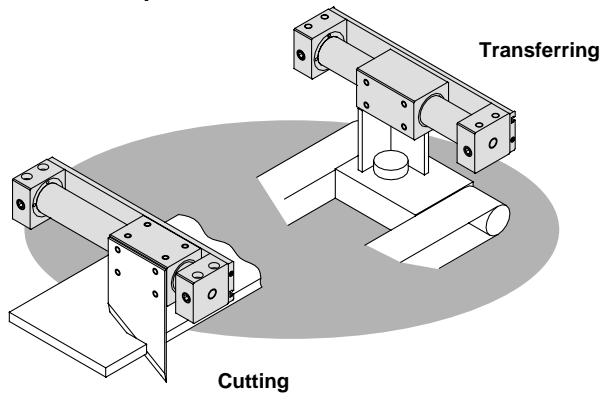

Series CY3B/CY3R

Model Selection Method

E: Kinetic energy of load (J)

$$E = \frac{(W + W_b)}{2} \times \left(\frac{V}{1000}\right)^2$$

Es: Allowable kinetic energy for intermediate stop using an air pressure circuit (J)

Fn: Allowable driving force (N)

Mb: Maximum allowable moment (N·m) when a connection bracket, etc. is carried directly

Ps: Operating pressure limit for intermediate stop using an external stopper, etc. (MPa)

Pv: Maximum operating pressure for vertical operation (MPa)

Wbmax: Maximum load weight (kg) when loaded directly on the body

Operating conditions	
· W: Load weight (kg)	· Switches
· Wb: Connection bracket weight (kg)	· P: Operating pressure (MPa)
· μ: Guide's coefficient of friction	· V: Speed (mm/s)
· Lc: Distance from cylinder shaft center to work piece point of application (cm)	· Stroke (mm)
· L1: Distance from cylinder shaft center to connection fitting, etc.	· Mode of operation (horizontal, inclined, vertical)

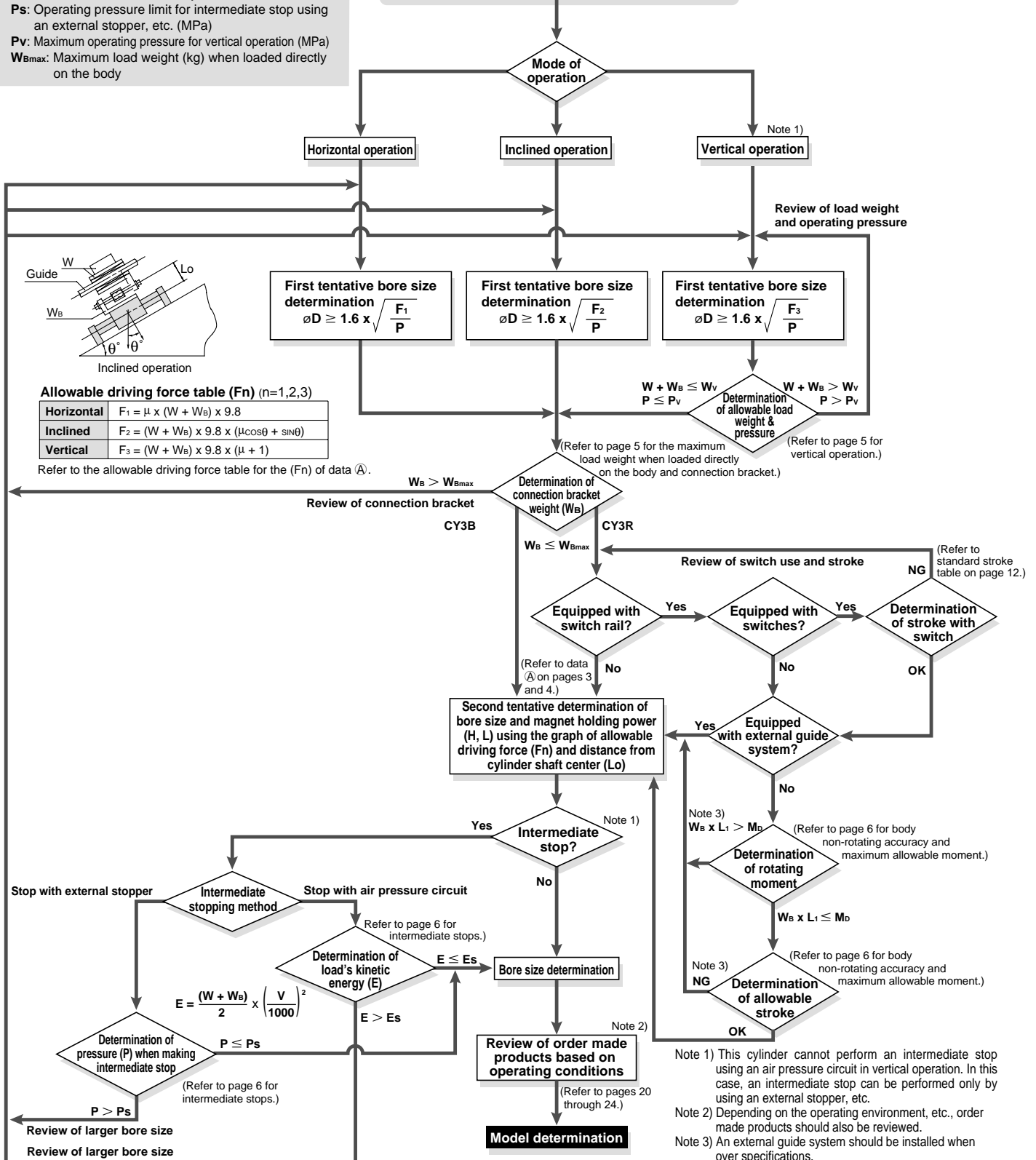

Series CY3B/CY3R

Model Selection Method

Precautions on Design ①

Selection procedure

Selection procedure

1. Find the drive resisting force F_n (N) when moving the load horizontally.
2. Find the distance L_o (cm) from the point of the load where driving force is applied, to the center of the cylinder shaft.
3. Select the bore size and type of magnet holding force (types H, L) from L_o and F_n based on data (A).

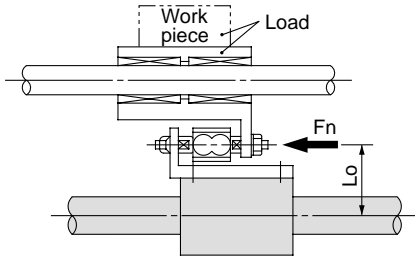

Selection example

Given a load drive resisting force of $F_n = 100$ (N) and a distance from the cylinder shaft center to the load application point of $L_o = 8$ cm, find the intersection point by extending upward from the horizontal axis of data (A) where the distance from the shaft center is 8 cm, and then extending to the side, find the allowable driving force on the vertical axis.

Models suitable to satisfy the requirement of 100 (N) are **CY3□32** or **CY3□40**.

<Data (A): Distance from cylinder shaft center — Allowable driving capacity>

CY3B15

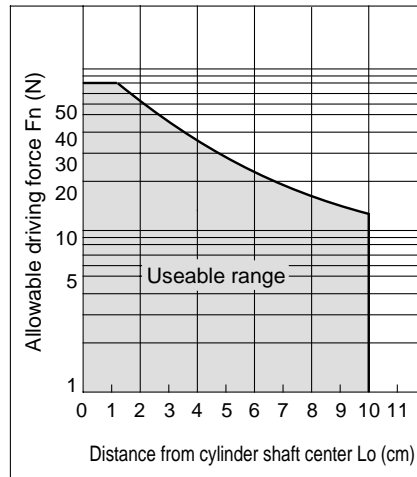

CY3B32

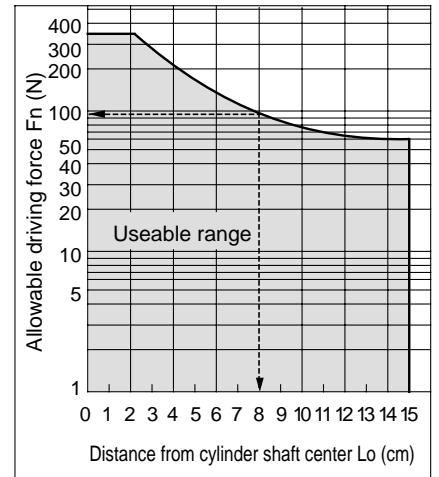

CY3B20

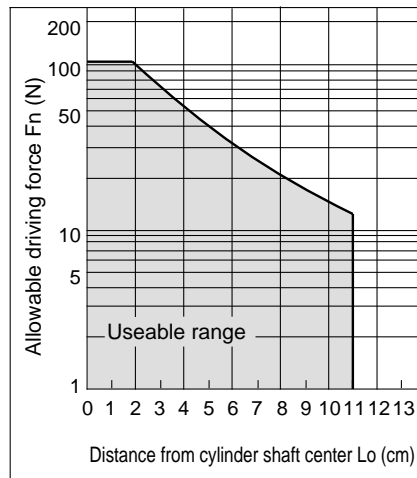

CY3B40

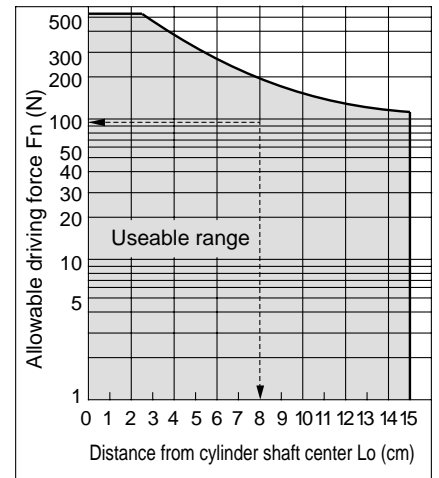

CY3B25

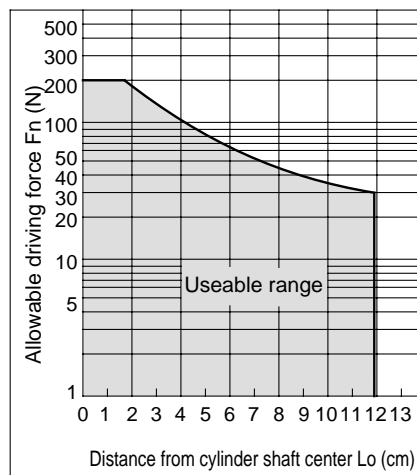

Precautions on Design ①

<Data (A) : Distance from cylinder shaft center — Allowable driving capacity>

CY3R15

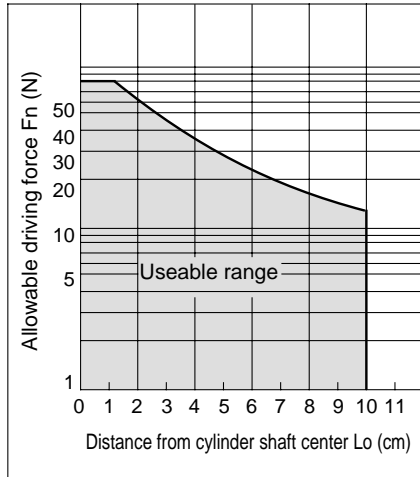

CY3R32

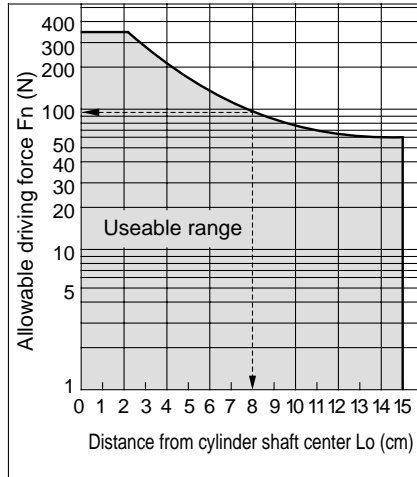

CY3R20

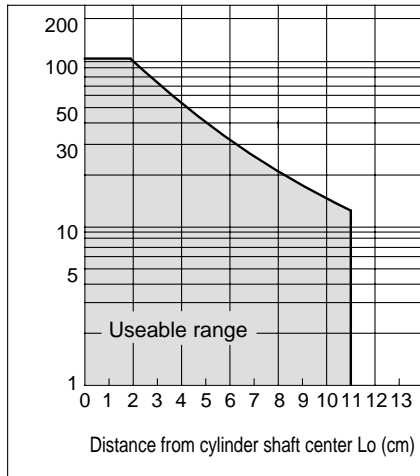

CY3R40

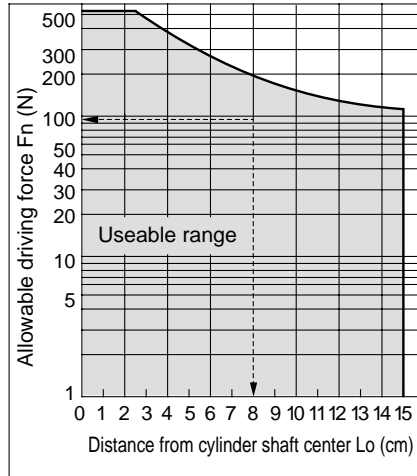

CY3R25

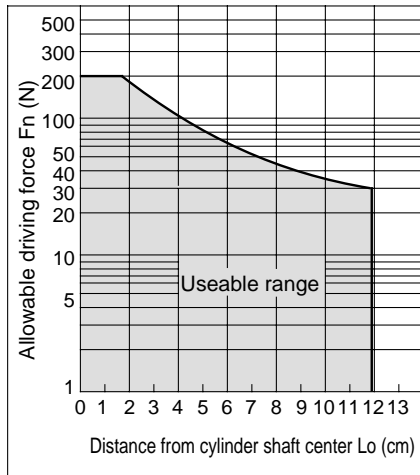

Series CY3B/CY3R Model Selection Method

Precautions on Design ②

Cylinder Dead Weight Deflection

When the cylinder is mounted horizontally, deflection appears due to its own weight as shown in the data, and the longer the stroke is, the greater the amount of variation in the shaft center. Therefore, a connection method should be considered which can assimilate this deflection.

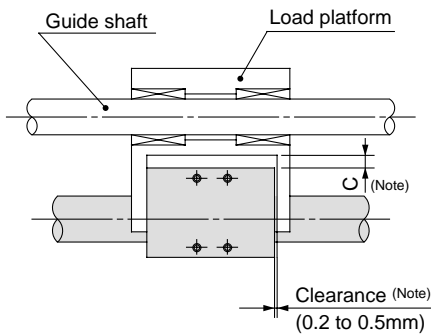

The above clearance amount is a reference value.

Note 1) According to the dead weight deflection in the figure on the right, provide clearance so that the cylinder does not touch the mounting surface or the load, etc., and is able to operate smoothly within the minimum operating pressure range for a full stroke. For more information, refer to instruction manual.

Note 2) In case of CY3R, install a stay, etc. to eliminate clearance between the body and the switch rail. For more information, refer to CY3R instruction manual.

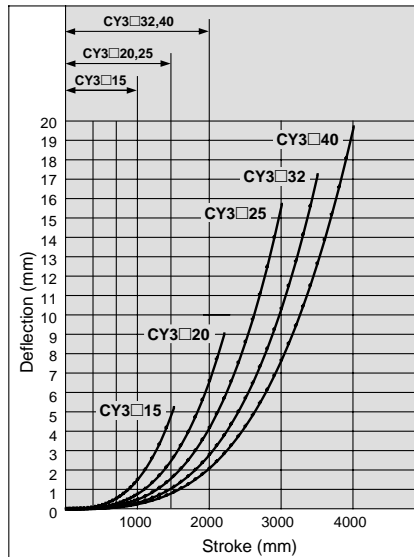
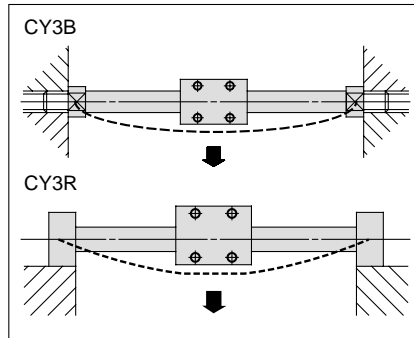

*The above deflection data represent values at the time when the external sliding part moves to the middle of the stroke.

Vertical Operation

The load should be guided by a ball type bearing (LM guide, etc.). If a slide bearing is used, sliding resistance increases due to the load weight and load moment, which can cause malfunction.

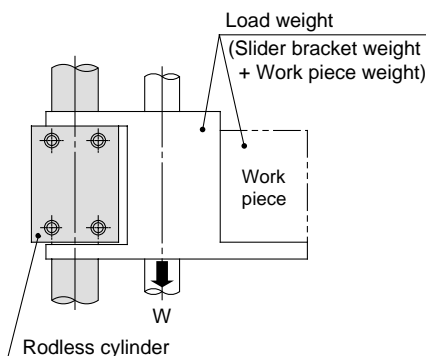

Bore size (mm)	Model	Allowable load weight (Wv) (kg)	Max. operating pressure (Pv) (MPa)
15	CY3□15	7.0	0.65
20	CY3□20	11.0	0.65
25	CY3□25	18.5	0.65
32	CY3□32	30.0	0.65
40	CY3□40	47.0	0.65

*Use caution, as there is a danger of breaking the magnetic coupling if operated above the maximum operating pressure.

Max. Weight of Connection Bracket to the Body

Series CY3 is guided by an external axis (such as a linear guide) without directly mounting the load. When designing a metal bracket to connect the load, see to it that its weight will not exceed the value in the table below. Basically, guide the CY3R direct mounting type also with an external axis. (For connection methods, refer to Instruction Manual.)

Model	Max. connection bracket weight (W _{max}) (kg)
CY3□15	1.0
CY3□20	1.1
CY3□25	1.2
CY3□32	1.5
CY3□40	2.0

Consult SMC in case a bracket with weight exceeding the above value is to be mounted.

<CY3R>

Max. Load Weight when Loaded Directly on Body

When the load is applied directly to the body, it should be no greater than the maximum values shown in the table below.

Model	Max. load weight (W _{max}) (kg)
CY3R15	1.0
CY3R20	1.1
CY3R25	1.2
CY3R32	1.5
CY3R40	2.0

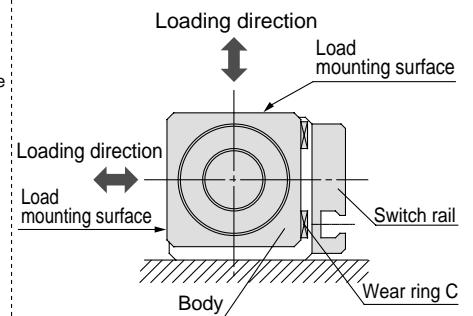

Precautions on Design ③

Intermediate stop

(1) Intermediate stopping of load with an external stopper, etc.

When stopping a load in mid-stroke using an external stopper, etc., operate within the operating pressure limits shown in the table below. Use caution, as operation at a pressure exceeding these limits can result in breaking of the magnetic coupling.

Bore size (mm)	Model	Operating pressure limit for intermediate stop (Ps) (MPa)
15	CY3□15	0.65
20	CY3□20	0.65
25	CY3□25	0.65
32	CY3□32	0.65
40	CY3□40	0.65

(2) Intermediate stopping of load with an air pressure circuit

When performing an intermediate stop of a load using an air pressure circuit, operate at or below the kinetic energy shown in the table below. Use caution, as operation when exceeding the allowable value can result in breaking of the magnetic coupling.

(Reference values)

Bore size (mm)	Model	Allowable kinetic energy for intermediate stop (Es) (J)
15	CY3□15	0.13
20	CY3□20	0.24
25	CY3□25	0.45
32	CY3□32	0.88
40	CY3□40	1.53

Stroke End Stopping Method

When stopping a load having a large inertial force at the stroke end, tilting of the body and damage to the bearings and cylinder tube may occur. (Refer to the left hand drawing below.)

As shown in the right hand drawing below, a shock absorber should be used together with the stopper, and thrust should also be transmitted from the center of the body so that tilting will not occur.

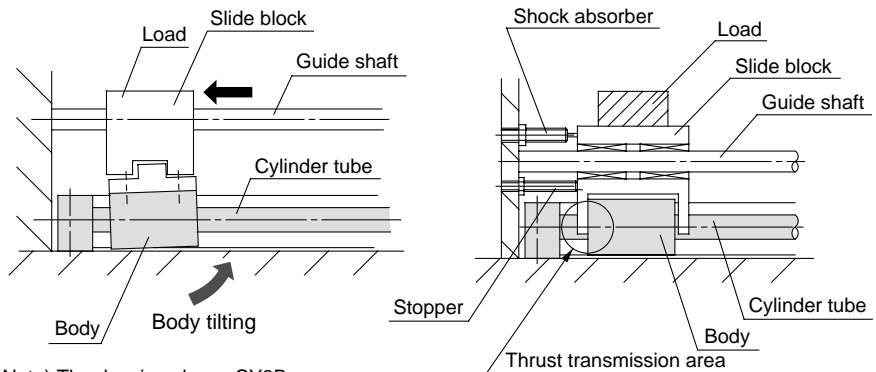

Note) The drawing shows CY3B.

<CY3R>

Body Non-rotating Accuracy and Maximum Allowable Moment (with Switch Rail) (Reference Values)

Reference values for non-rotating accuracy and maximum allowable moment at stroke end are indicated below.

Bore size (mm)	Non-rotating accuracy (β)	Max. allowable moment (Mb) (N·m)	Note 2) Allowable stroke (mm)
15	4.5	0.15	200
20	3.7	0.20	300
25	3.7	0.25	300
32	3.1	0.40	400
40	2.8	0.62	400

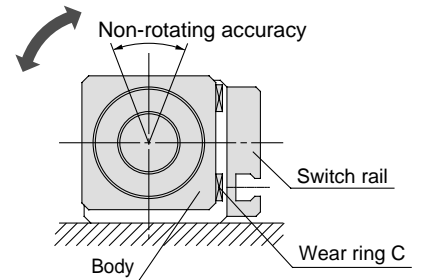

Note 1) Avoid operations where rotational torque (moment) is applied. In such a case, the use of an external guide is recommended.

Note 2) The above reference values will be satisfied within the allowable stroke ranges, but caution is necessary, because as the stroke becomes longer, the inclination (rotation angle) within the stroke can be expected to increase.

Note 3) When a load is applied directly to the body, the loaded weight should be no greater than the allowable load weights on page 5.

Series CY3B

Basic Type

How to Order

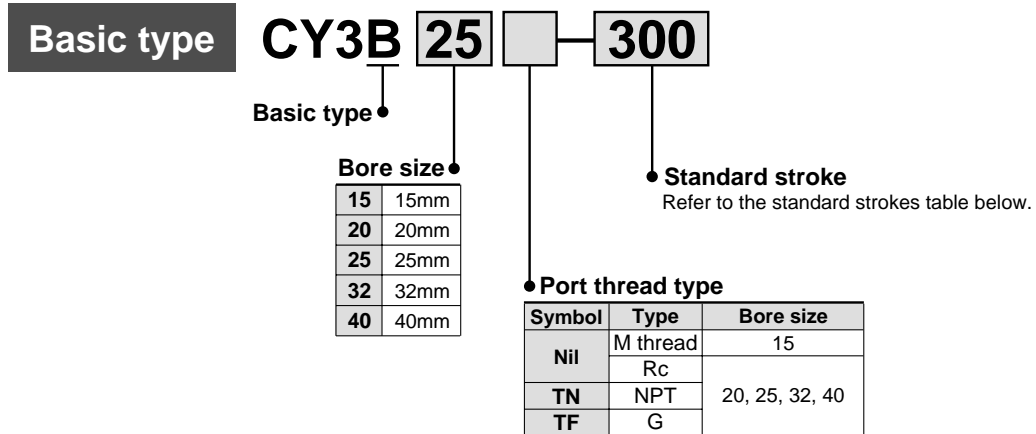

Standard Stroke

Bore size (mm)	Standard stroke (mm)	Maximum stroke ^{Note 1)} available (mm)
15	50, 100, 150, 200, 250, 300, 350 400, 450, 500	1000
20	100, 150, 200, 250, 300, 350, 400, 450	1500 ^{Note 2)}
25, 32	500, 600, 700, 800	3000
40	100, 150, 200, 250, 300, 350, 400, 450 500, 600, 700, 800, 900, 1000	3000

Note 1) Contact SMC if the maximum stroke will be exceeded.

Note 2) Use series CY1B if the stroke exceeds 1500 mm with a tube inside diameter of 20 mm.

Magnetic Holding Force (N)

Bore size (mm)	15	20	25	32	40
Holding force (N)	137	231	363	588	922

Specifications



JIS symbol

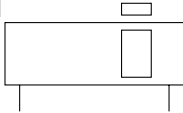

Fluid	Air
Proof pressure	1.05MPa
Max. operating pressure	0.7MPa
Min. operating pressure	Refer to the minimum operating pressure table.
Ambient and fluid temperature	-10 to 60°C
Piston speed	50 to 400mm/s
Cushion	Rubber bumper at both ends
Lubrication	Non-lube
Stroke length tolerance	0 to 250st: $^{+1.0}_0$, 251 to 1000st: $^{+1.4}_0$, 1001st to: $^{+1.8}_0$
Mounting orientation	Unrestricted
Mounting nut (2 pcs.)	Standard equipment (accessory)



Made to Order specifications
(Refer to pages 20 through 24 for details.)

Symbol	Specifications
-XB11	Long stroke (2001mm and up)
-XB13	Low speed specifications (7 to 50mm/s)
-X116	Hydro specifications
-X132	Axial ports
-X160	High speed specifications
-X168	Helical insert thread specifications
-X206	Added mounting tap positions for slider
-X210	Oil-free exterior specifications
-X322	Outside of cylinder tube with hard chrome plating
-X324	Oil-free exterior specifications (with dust seal)
-XC57	With floating joint

Minimum Operating Pressure

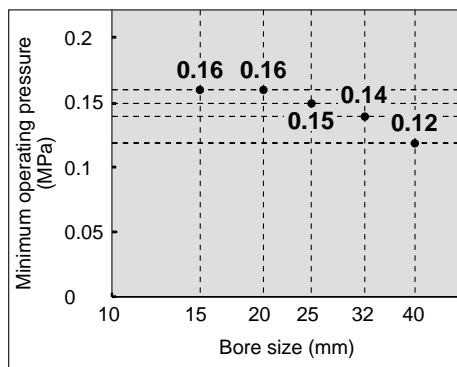

Theoretical Cylinder Thrust ⚠ Caution

When calculating the actual thrust, design should consider the minimum actuating pressure.

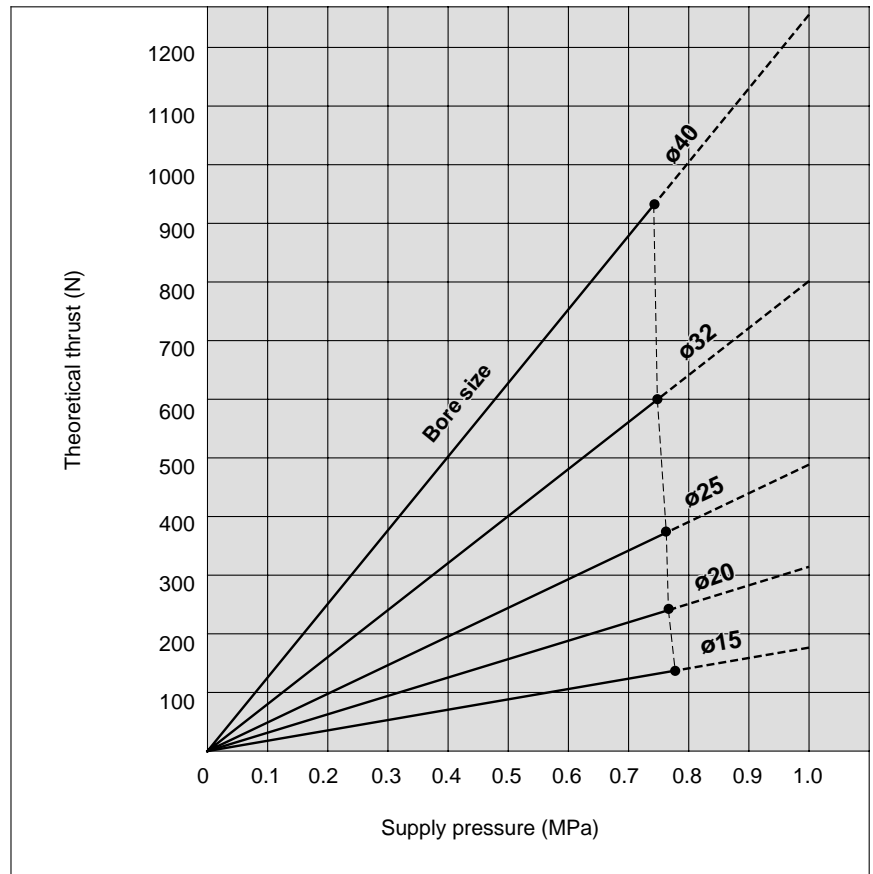

Main Material

Description	Material	Note
Head cover	Aluminum alloy	Electroless nickel plated
Cylinder tube	Stainless steel	
Body	Aluminum alloy	Hard anodized
Magnet	Rare earth magnet	

Weights

Bore size (mm)	15	20	25	32	40
Basic weight	0.275	0.351	0.672	1.287	2.070
Additional weight per 50mm of stroke	0.015	0.02	0.023	0.033	0.04

Calculation method
/Example: CY3B32-500

Basic weight 1.287kg
Additional weight 0.033kg/50s } $1.287 + 0.033 \times 500 \div 50 = 1.617\text{kg}$
Cylinder stroke 500st

Series CY3B

Construction

Basic type

CY3B15

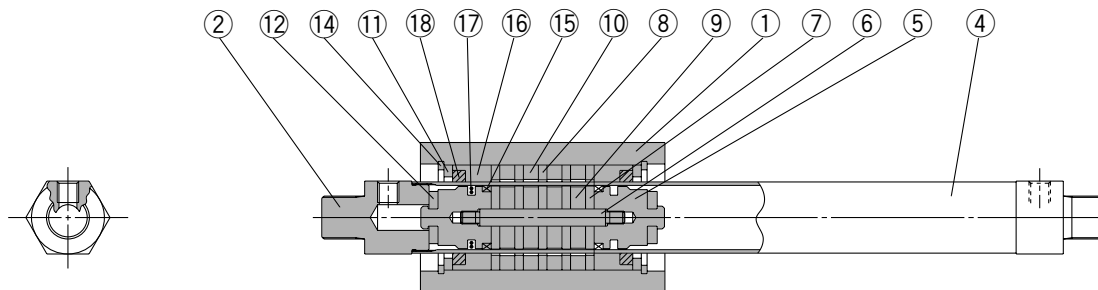

CY3B20 to 40

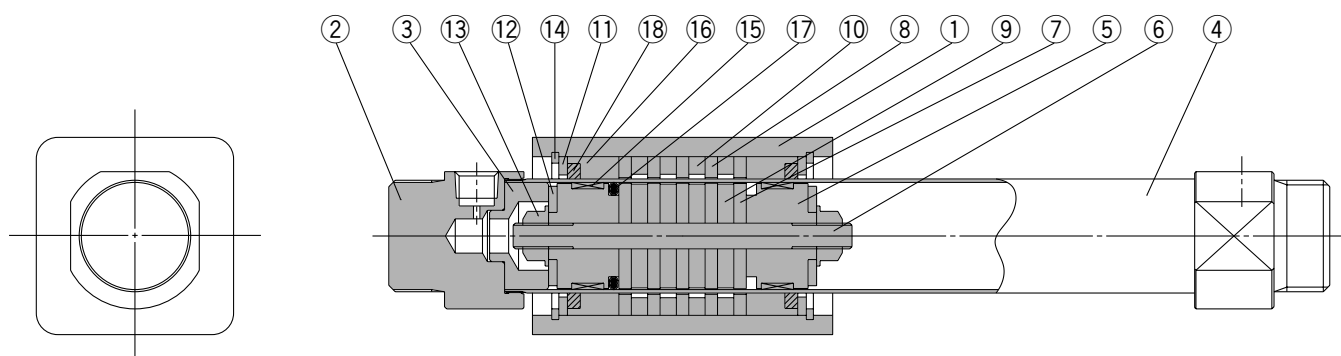

Parts list

No.	Description	Material	Note
1	Body	Aluminum alloy	Hard anodized
2	Head cover	Aluminum alloy	Electroless Ni plated
3	End collar	Aluminum alloy	Chromate (ø15 is not available.)
4	Cylinder tube	Stainless steel	
5	Piston	Aluminum alloy	Chromate
6	Shaft	Stainless steel	
7	Piston side yoke	Rolled steel	Zinc chromate
8	External slider side yoke	Rolled steel	Zinc chromate
9	Magnet A	Rare earth magnet	
10	Magnet B	Rare earth magnet	
11	Spacer	Aluminum alloy	Chromate
12	Bumper	Urethane rubber	
13	Hexagon nut with flange	Carbon steel	Zinc chromate (ø15: not available. ø20: hexagon nut)
14	C type snap ring for hole	Carbon tool steel	Nickel plated
15	Wear ring A	Special resin	
16	Wear ring B	Special resin	
17	Piston seal	NBR	
18	Soft wiper	Special resin	

Replacement parts: Seal kits

Bore size (mm)	Kits no.
15	CY3B15-PS
20	CY3B20-PS
25	CY3B25-PS
32	CY3B32-PS
40	CY3B40-PS

*Seal kits are sets consisting of numbers 15 through 18, and may be ordered using the order number to each bore size.

Dimensions

Basic type

CY3B15 to 40

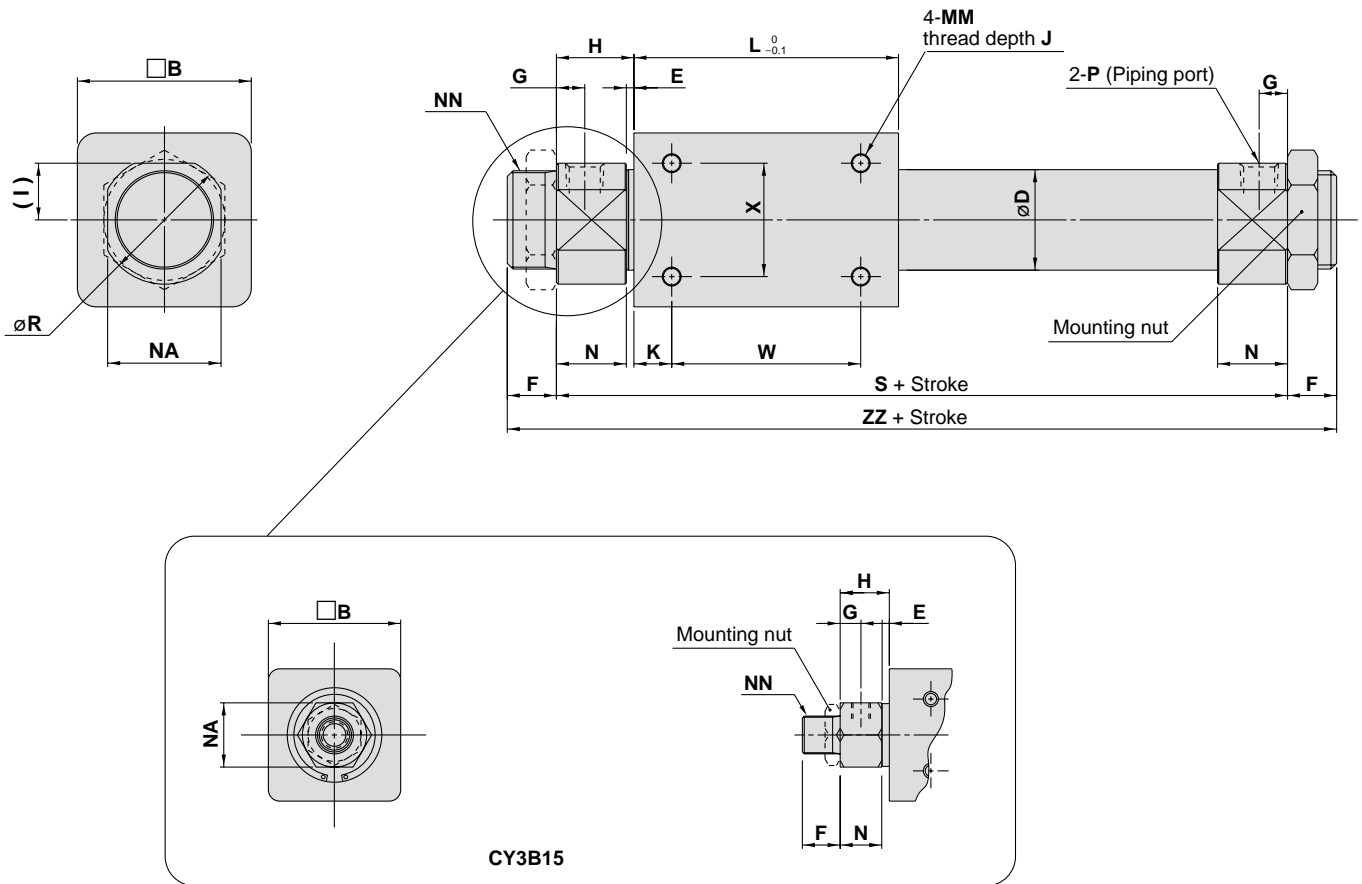

Model	B	D	E	F	G	H	I	J	K	L	MM	N	NA	NN	R	S	W	X	ZZ
CY3B15	35	16.6	3	10	5.5	13	—	6	11	57	M4 x 0.7	11	17	M10 x 1	—	83	35	19	103
CY3B20	36	21.6	2	13	7.5	20	12	6	8	66	M4 x 0.7	18	24	M20 x 1.5	28	106	50	25	132
CY3B25	46	26.4	2	13	7.5	20.5	15	8	10	70	M5 x 0.8	18.5	30	M26 x 1.5	34	111	50	30	137
CY3B32	60	33.6	2	16	8	22	18	8	15	80	M6 x 1	20	36	M26 x 1.5	40	124	50	40	156
CY3B40	70	41.6	3	16	11	29	23	10	16	92	M6 x 1	26	46	M32 x 2	50	150	60	40	182

Model	P (Piping port)		
	Nil	TN	TF
CY3B15	M5 x 0.8	—	—
CY3B20	Rc 1/8	NPT 1/8	G 1/8
CY3B25	Rc 1/8	NPT 1/8	G 1/8
CY3B32	Rc 1/8	NPT 1/8	G 1/8
CY3B40	Rc 1/4	NPT 1/4	G 1/4

Mounting nut/Included in the package (2 pcs).

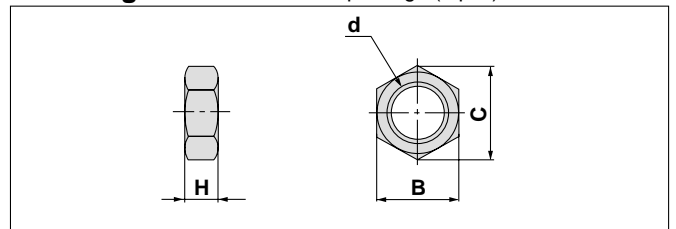

Part No.	Applicable bore size (mm)	d	H	B	C
SNJ-016B	15	M10 x 1.0	4	14	16.2
SN-020B	20	M20 x 1.5	8	26	30
SN-032B	25, 32	M26 x 1.5	8	32	37
SN-040B	40	M32 x 2.0	10	41	47.3

Series CY3R

Direct Mount Type

How to Order

CY3R **25** **300** **Y7BW**

Direct mount type

Piping type

Nil	Both sides piping type
G	Centralized piping type

Bore size

15	15mm
20	20mm
25	25mm
32	32mm
40	40mm

Port thread type

Symbol	Type	Bore size
Nil	M thread	15
	Rc	
TN	NPT	20, 25, 32, 40
TF	G	

Number of auto switches

Nil	2 pcs.
S	1 ps.
n	"n" pcs.

Auto switch type

Nil	Without auto switch
-----	---------------------

Switch rail

Nil	With switch rail
N	Without switch rail

Standard stroke

Refer to page 12 for standard stroke.

Note 1) In case of $\phi 20$ with switch rail but without switch, the cylinder construction is for reed switch.
*Refer to the table below for auto switch model numbers.
*The auto switch is packed together when shipped (unmounted).

Note 1) A type with switch rail has built-in switch magnets.
Note 2) $\phi 15$ has built-in switch magnets even without switch rail.

Applicable auto switches/ The applicable auto switch is determined by the tube inside diameter. Refer to Best Pneumatics for the detailed specifications of auto switches. Refer to page 18 for auto switch circuit diagrams.

For $\phi 15, \phi 20$

Type	Special function	Electrical entry	Indicator light	Wiring (output)	Load voltage		Auto switch models	Lead wire length (m)*			Applicable load							
					DC	AC		0.5 (Nil)	3 (L)	5 (Z)								
Reed switch	—	Grommet	No	2-wire	24V	5V, 12V	100V or less	A90	●	●	—	IC circuit	Relay PLC					
			No											12V	100V	A93	●	●
Solid state switch	—	Grommet	Yes	3-wire (NPN)	24V	5V, 12V	—	F9N	●	●	○	IC circuit	Relay PLC					
				3-wire (PNP)										F9P	●	●	○	—
				2-wire										F9B	●	●	○	—
				3-wire (NPN)										F9NW	●	●	○	IC circuit
				3-wire (PNP)										F9PW	●	●	○	—
				2-wire										F9BW	●	●	○	—
				Diagnostic indication (2-color display)										—	—	—	—	—

For $\phi 25, \phi 32, \phi 40$

Type	Special function	Electrical entry	Indicator light	Wiring (output)	Load voltage		Auto switch models	Lead wire length (m)*			Applicable load							
					DC	AC		0.5 (Nil)	3 (L)	5 (Z)								
Reed switch	—	Grommet	Yes	3-wire (NPN equiv.)	24V	5V	—	Z76	●	●	—	IC circuit	—					
			No	2-wire										12V	100V	Z73	●	●
Solid state switch	—	Grommet	Yes	3-wire (NPN)	24V	5V, 12V	—	Y59A	●	●	○	IC circuit	Relay PLC					
				3-wire (PNP)										Y7P	●	●	○	—
				2-wire										Y59B	●	●	○	—
				3-wire (NPN)										Y7NW	●	●	○	IC circuit
				3-wire (PNP)										Y7PW	●	●	○	—
				2-wire										Y7BW	●	●	○	—
Diagnostic indication (2-color display)	—	—	—	—	—	—	—	—	—	—	—	—						

*Lead wire length symbols: 0.5m..... Nil (Example) Y59B
3m..... L (Example) Y59BL
5m..... Z (Example) Y59BZ

**Solid state switches marked "○" are produced upon receipt of order.

Specifications



Made to Order specifications
(Refer to pages 20 through 24 for details.)

Symbol	Specifications
—X116	Hydro specifications
—X160	High speed specifications
—X168	Helical insert thread specifications
—X322	Outside of cylinder tube with hard chrome plating
—XC57	With floating joint

Minimum Operating Pressure

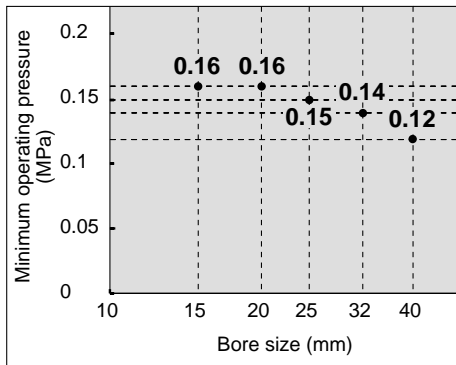

Weights

Unit: kg

Item		Bore size (mm)				
		15	20	25	32	40
Basic weight (at 0st)	CY3R CY3RG (with switch rail)	0.272	0.421	0.622	1.217	1.980
	CY3R (without switch rail)	0.225	0.351	0.542	1.097	1.820
Additional weight per 50mm of stroke (with switch rail)		0.04	0.051	0.056	0.076	0.093
Additional weight per 50mm of stroke (without switch rail)		0.015	0.02	0.023	0.033	0.04

Calculation method
/Example: CY3R25-500 Basic weight0.622kg
(with switch rail) Additional weight0.056kg/50s
Cylinder stroke500st
0.622 + 0.056 x 500 ÷ 50 = 1.182 (kg)

Fluid	Air
Proof pressure	1.05MPa
Max. operating pressure	0.7MPa
Min. operating pressure	Refer to the minimum operating pressure table.
Ambient and fluid temperature	-10 to 60°C
Piston speed ^{Note)}	50 to 500mm/s
Cushion	Rubber bumper at both ends
Lubrication	Non-lube
Stroke length tolerance	0 to 250st: $+1.0_0$, 251 to 1000st: $+1.4_0$, 1001st to : $+1.8_0$
Mounting	Direct mount type

Note) When an auto switch is installed at an intermediate position of a type with auto switch, keep the maximum piston speed at 300 mm/s or below to ensure operation of relays or other devices.

Standard Strokes

Bore size (mm)	Standard stroke (mm)	Max. stroke ^{Note 1)} without switch (mm)	Max. stroke ^{Note 1)} with switch (mm)
15	50, 100, 150, 200, 250, 300	1000	750
	350, 400, 450, 500		
20	100, 150, 200, 250, 300, 350	1500	1000
	400, 450, 500, 600, 700, 800		
25	100, 150, 200, 250, 300, 350	1500	1200
	400, 450, 500, 600, 700, 800		
32	100, 150, 200, 250, 300, 350	2000	1500
	400, 450, 500, 600, 700, 800		
40	100, 150, 200, 250, 300, 350	2000	1500
	400, 450, 500, 600, 700, 800		
	900, 1000		

Note 1) Contact SMC if the maximum stroke will be exceeded.

Note 2) When installing the cylinder, refer to Selection Method (page 31) to handle the dead weight deflection.

Magnetic Holding Force (N)

Bore size (mm)	15	20	25	32	40
Holding force (N)	137	231	363	588	922

Theoretical Cylinder Thrust

⚠ Caution When calculating the actual thrust, design should consider the 12 minimum actuating pressure.

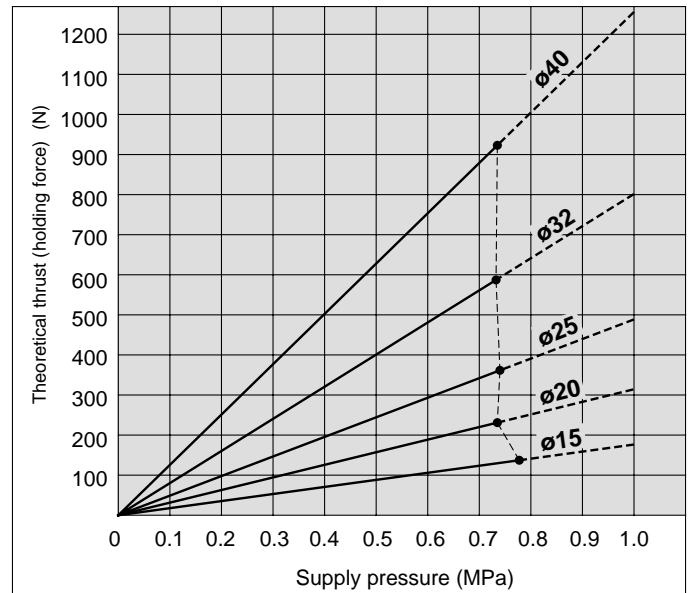

Series CY3R

Construction

Both sides piping type

CY3R15 to 40

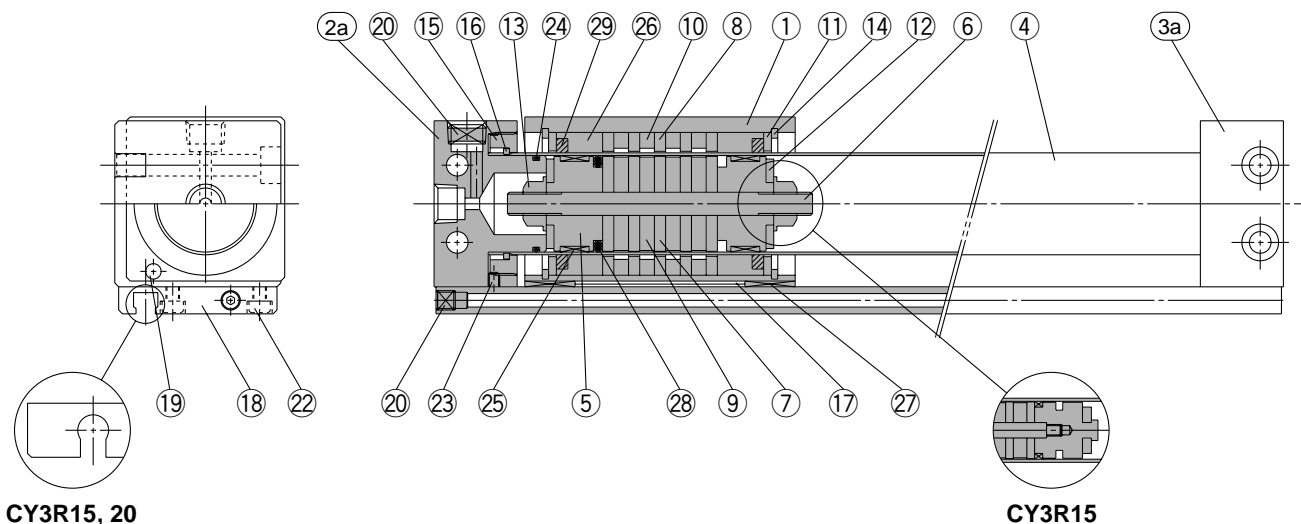

CY3R15, 20

CY3R15

Parts list

No.	Description	Material	Note
1	Body	Aluminum alloy	Hard anodized
2a	End cover A	Aluminum alloy	Electroless nickel plated
2b	End cover C	Aluminum alloy	Electroless nickel plated
3a	End cover B	Aluminum alloy	Electroless nickel plated
3b	End cover D	Aluminum alloy	Electroless nickel plated
4	Cylinder tube	Stainless steel	
5	Piston	ø15: Brass ø20 to ø40: Aluminum alloy	ø15: Electroless nickel plated ø20 to ø40: Chromate
6	Shaft	Stainless steel	
7	Piston side yoke	Rolled steel plate	Zinc chromated
8	External slider side yoke	Rolled steel plate	Zinc chromated
9	Magnet A	Rare earth magnet	
10	Magnet B	Rare earth magnet	
11	Spacer	Aluminum alloy	Black anodized
12	Bumper	Urethane rubber	
13	Piston nut	Carbon steel	ø20 to ø40
14	Snap ring	Carbon tool steel	Nickel plated
15	Attachment ring	Aluminum alloy	Chromate
16	C type snap ring for shaft	Hard steel wire	
17	Magnetism shielding plate	Rolled steel plate	Chromated
18	Switch rail	Aluminum alloy	White anodized
19	Magnet	Rare earth magnet	
20	Hexagon socket head plug	Chromium steel	Nickel plated

No.	Description	Material	Note
21	Steel balls	Chromium steel	ø40: Hexagon socket head plug ø20: None
22	Hexagon socket head screw	Chromium steel	Nickel plated
23	Hexagon socket head set screw	Chromium steel	Nickel plated
24*	Cylinder tube Gasket	NBR	
25*	Wear ring A	Special resin	
26*	Wear ring B	Special resin	
27*	Wear ring C	Special resin	
28*	Piston seal	NBR	
29*	Soft wiper	Special resin	
30*	Switch rail Gasket	NBR	Both sides piping type: None

*Seal kits are sets consisting of numbers 24 through 30, and may be ordered using the order number to each bore size.

Replacement parts: Seal kits

Bore size (mm)	Kits no.	Contents
15	CY3R15-PS	Numbers 24, 25, 26, 27, 28, 29, 30 above
20	CY3R20-PS	
25	CY3R25-PS	
32	CY3R32-PS	
40	CY3R40-PS	

*Seal kits are the same for both the both sides piping type and the centralized piping type.

Dimensions

Centralized piping type

CY3RG15 to 40

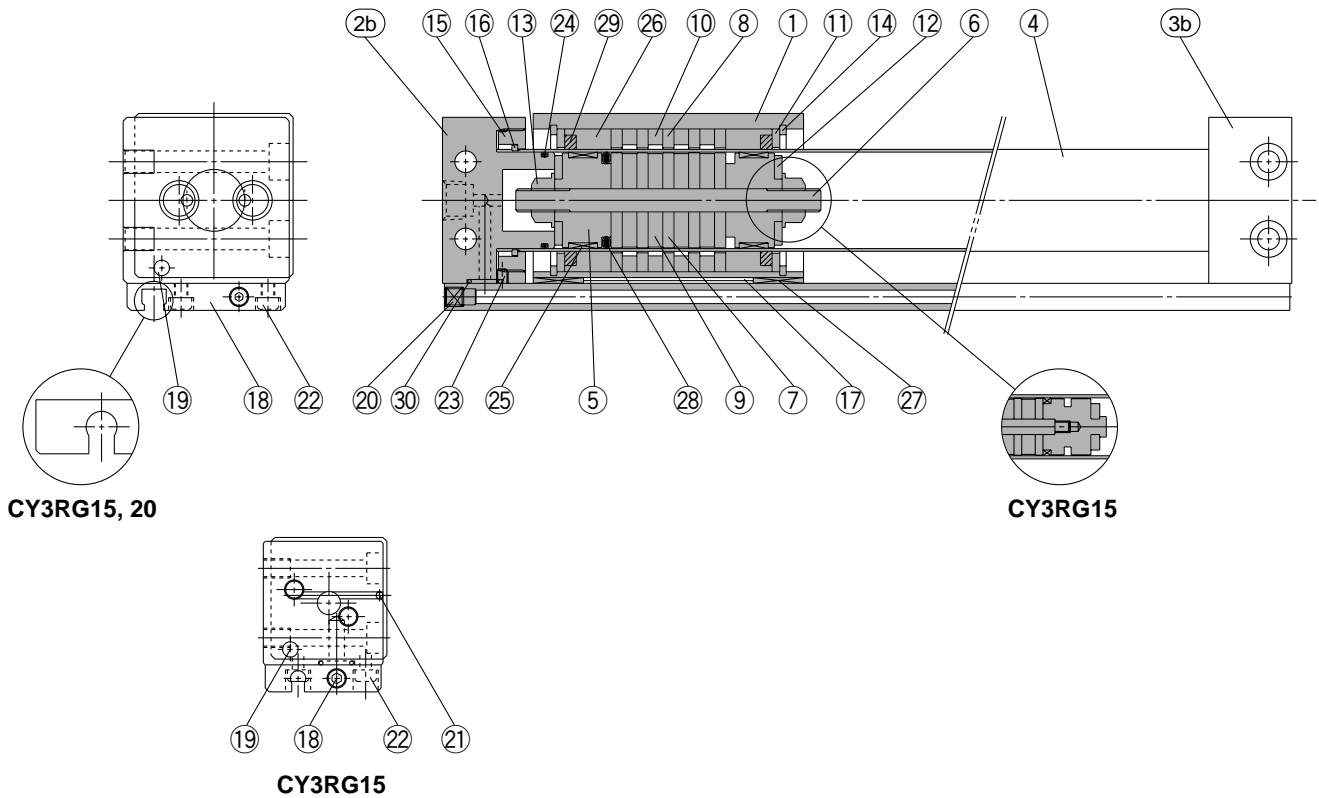

Replacement parts: Seal kits

Bore size (mm)	Kits no.	Contents
15	CY3R15-PS	Numbers 24, 25, 26, 27, 28, 29, 30 at the left
20	CY3R20-PS	
25	CY3R25-PS	
32	CY3R32-PS	
40	CY3R40-PS	

*Seal kits are the same for both the both sides piping type and the centralized piping type.

Switch Rail Accessory

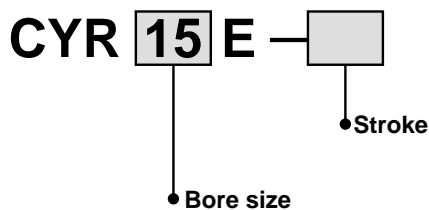

Switch rail accessory kits

Bore size (mm)	Kits no.	Contents
15	CYR15E-□	Numbers ^{Note 2)} 17, 18, 20, 22, 27 at the left
20	For reed switch CYR20E-□	Numbers 17, 18, 20, 22, 27 at the left
	For solid state switch CYR20EN-□	
25	CYR25E-□	
32	CYR32E-□	
40	CYR40E-□	

Note 1) □ indicates to the stroke.

Note 2) A magnet is already built in for ø15.

Series CY3R

Dimensions

Both sides piping type: $\phi 15$ to $\phi 40$

Note 1) This figure shows types with switch rail (no symbol).

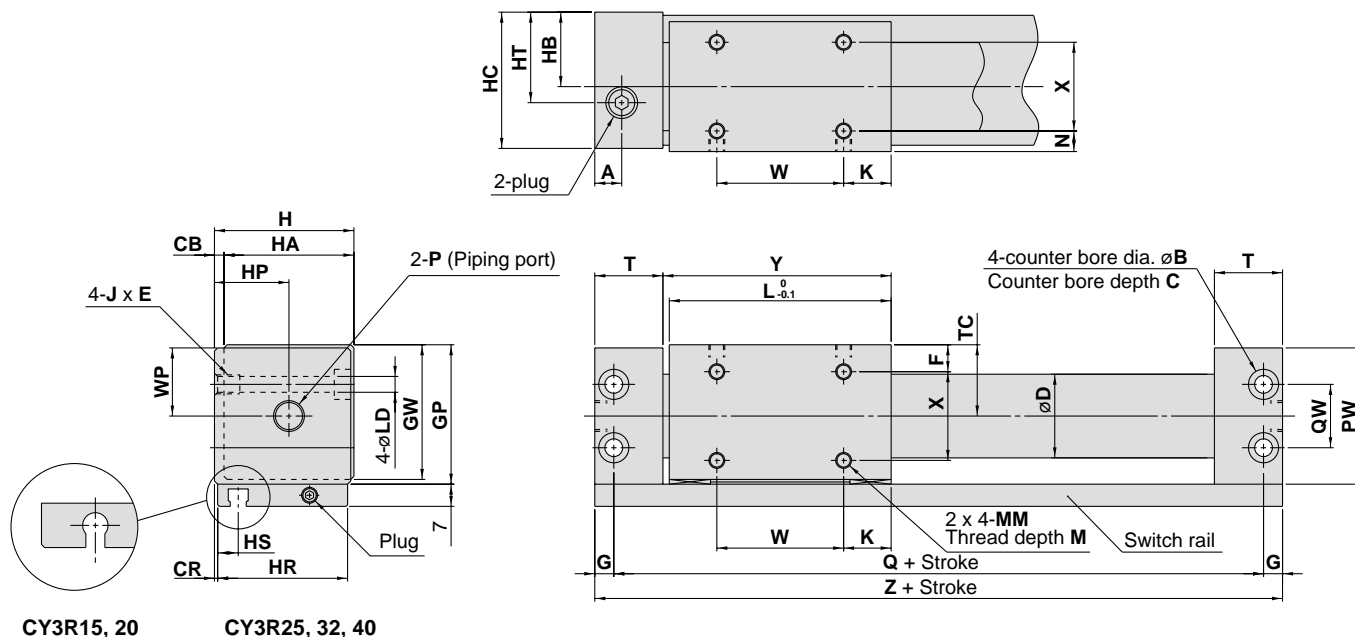

CY3R15, 20

CY3R25, 32, 40

Model	A	B	C	CB	CR	D	F	G	GP	GW	H	HA	HB	HC	HP	HR	HS	HT	J x E	K
CY3R15	10.5	8	4.2	2	0.5	16.6	8	5	33	31.5	32	30	17	31	17	30	8.5	17	M5 x 0.8 x 7	14
CY3R20	9	9.5	5.2	3	1	21.6	9	6	39	37.5	39	36	21	38	24	36	7.5	24	M6 x 1 x 8	11
CY3R25	8.5	9.5	5.2	3	1	26.4	8.5	6	44	42.5	44	41	23.5	43	23.5	41	6.5	23.5	M6 x 1 x 8	15
CY3R32	10.5	11	6.5	3	1.5	33.6	10.5	7	55	53.5	55	52	29	54	29	51	7	29	M8 x 1.25 x 10	13
CY3R40	10	11	6.5	5	2	41.6	13	7	65	63.5	67	62	36	66	36	62	8	36	M8 x 1.25 x 10	15

Model	L	LD	M	MM	N	PW	Q	QW	T	TC	W	WP	X	Y	Z
CY3R15	53	4.3	5	M4 x 0.7	6	32	84	18	19	17	25	16	18	54.5	94
CY3R20	62	5.6	5	M4 x 0.7	7	38	95	17	20.5	20	40	19	22	64	107
CY3R25	70	5.6	6	M5 x 0.8	6.5	43	105	20	21.5	22.5	40	21.5	28	72	117
CY3R32	76	7	7	M6 x 1	8.5	54	116	26	24	28	50	27	35	79	130
CY3R40	90	7	8	M6 x 1	11	64	134	34	26	33	60	32	40	93	148

Model	P (Piping port)		
	Nil	TN	TF
CY3R15	M5 x 0.8	—	—
CY3R20	Rc 1/8	NPT 1/8	G 1/8
CY3R25	Rc 1/8	NPT 1/8	G 1/8
CY3R32	Rc 1/8	NPT 1/8	G 1/8
CY3R40	Rc 1/4	NPT 1/4	G 1/4

Dimensions

Centralized piping type: $\varnothing 15$ to $\varnothing 40$

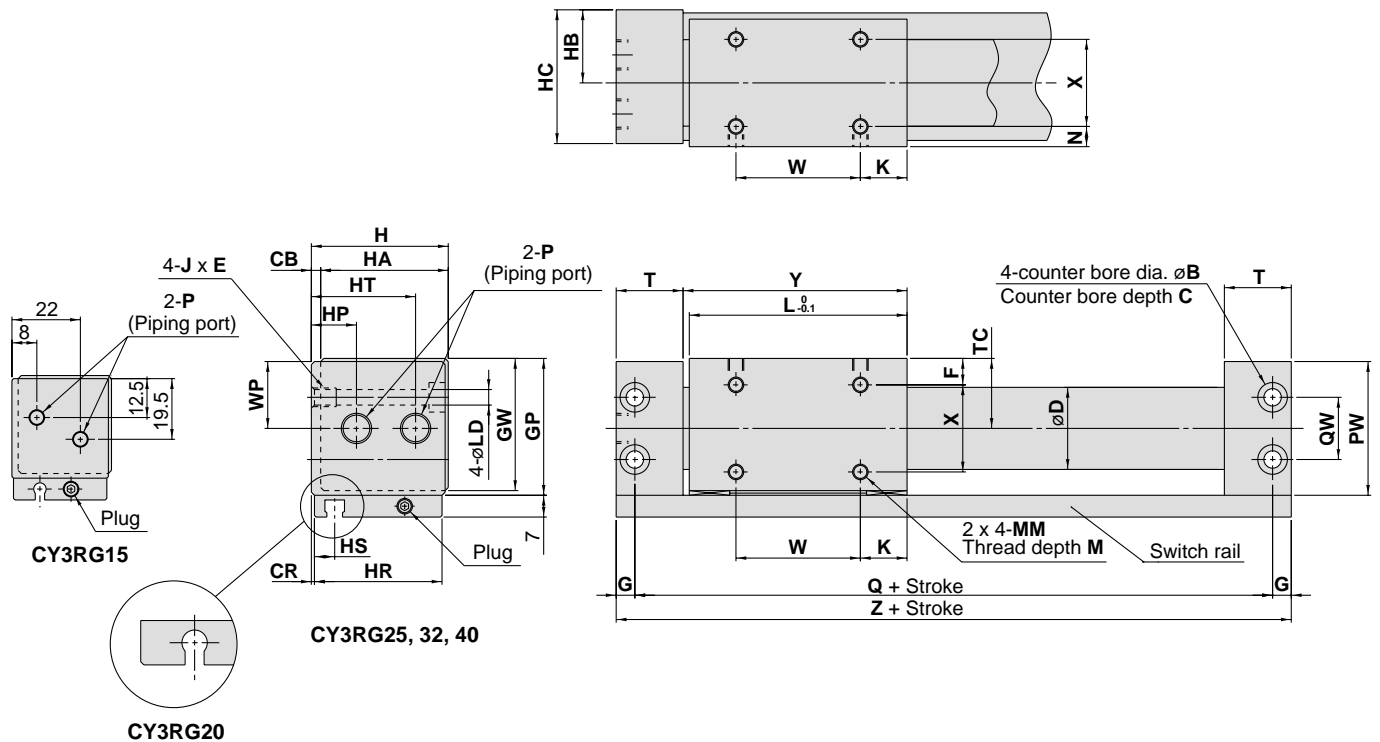

Model	B	C	CB	CR	D	F	G	GP	GW	H	HA	HB	HC	HP	HR	HS	HT	J x E	K	L
CY3RG15	8	4.2	2	0.5	16.6	8	5	33	31.5	32	30	17	31	—	30	8.5	—	M5 x 0.8 x 7	14	53
CY3RG20	9.5	5.2	3	1	21.6	9	6	39	37.5	39	36	21	38	11	36	7.5	28	M6 x 1 x 8	11	62
CY3RG25	9.5	5.2	3	1	26.4	8.5	6	44	42.5	44	41	23.5	43	14.5	41	6.5	33.5	M6 x 1 x 8	15	70
CY3RG32	11	6.5	3	1.5	33.6	10.5	7	55	53.5	55	52	29	54	20	51	7	41	M8 x 1.25 x 10	13	76
CY3RG40	11	6.5	5	2	41.6	13	7	65	63.5	67	62	36	66	25	62	8	50	M8 x 1.25 x 10	15	90

Model	LD	M	MM	N	PW	Q	QW	T	TC	W	WP	X	Y	Z
CY3RG15	4.3	5	M4 x 0.7	6	32	84	19	19	17	25	16	18	54.5	94
CY3RG20	5.6	5	M4 x 0.7	7	38	95	20.5	20.5	20	40	19	22	64	107
CY3RG25	5.6	6	M5 x 0.8	6.5	43	105	21.5	21.5	22.5	40	21.5	28	72	117
CY3RG32	7	7	M6 x 1	8.5	54	116	24	24	28	50	27	35	79	130
CY3RG40	7	8	M6 x 1	11	64	134	26	26	33	60	32	40	93	148

Model	P (Piping port)		
	Nil	TN	TF
CY3RG15	M5 x 0.8	—	—
CY3RG20	Rc 1/8	NPT 1/8	G 1/8
CY3RG25	Rc 1/8	NPT 1/8	G 1/8
CY3RG32	Rc 1/8	NPT 1/8	G 1/8
CY3RG40	Rc 1/4	NPT 1/4	G 1/4

Series CY3R

Auto Switch Proper Mounting Position for Stroke End Detection

(Reference dimension)

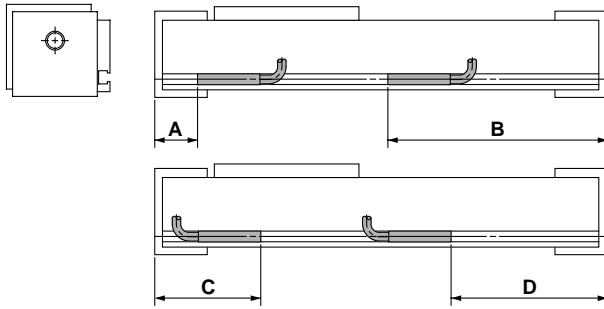

Auto Switch Operation Range

Auto switch model	Bore size (mm)				
	15	20	25	32	40
D-A9□	8	6	—	—	—
D-F9□, D-F9□W	5	4	—	—	—
D-Z7□, Z80	—	—	9	9	11
D-Y59□, Y7P D-Y7□W	—	—	6	6	6

*Switches cannot be mounted in some cases.
 *Operating ranges are standards including hysteresis, and are not guaranteed. (variation on the order of ±30%)
 Large variations may occur depending on the surrounding environment.

ø15, ø20 (mm)

Bore size (mm)	Applicable switch model							
	D-A9□				D-F9□, D-A9□W			
	A	B	C	D	A	B	C	D
15	17.5	76.5	—	56.5	21.5	72.5	—	60.5
20	19.5	87.5	39.5	67.5	23.5	83.5	35.5	71.5

Note 1) Auto switches cannot be installed in Area C in the case of ø15.
 Note 2) Only non-magnetic material is permitted as the mounting surface of a ø20 cylinder.

ø25, ø32, ø40 (mm)

Bore size (mm)	Applicable switch model			
	D-Z7□, Z80, Y59□, D-Y7P, Y7□W			
	A	B	C	D
25	18	99	43	74
32	21.5	108.5	46.5	83.5
40	23.5	124.5	48.5	99.5

Note 1) 50mm is the minimum stroke available with 2 auto switches mounted.
 Note 2) The above dimensions are given as reference dimensions. Confirm installation with actual equipment.

Auto Switch Mounting

When mounting auto switches, they should be inserted into the cylinder's switch groove from the direction shown in the drawing on the right. After setting in the mounting position, use a flat head watchmakers screw driver to tighten the mounting screw which is included.

Note) When tightening the auto switch mounting screw, use a watchmakers screw driver with a handle about 5 to 6mm in diameter. Furthermore, the tightening torque should be approximately 0.05 to 0.1N·m (0.51 to 1.02kgf·cm). As a rule, it can be turned about 90° past the point at which tightening can be felt.

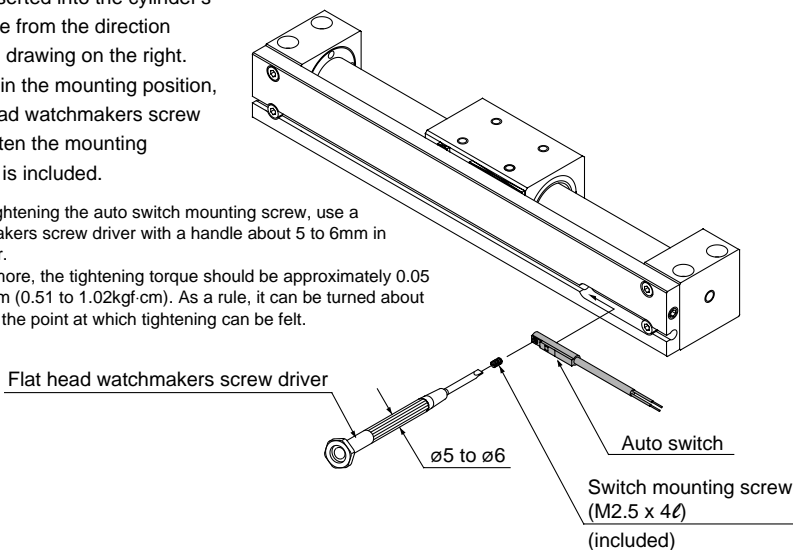

Auto Switch Specifications

- (1) Switches (switch rail) can be added to the standard type (without switch rail). The switch rail accessory type is mentioned on page 14, and can be ordered together with auto switches.
- (2) Refer to the separate disassembly instructions for switch magnet installation procedures.

Reed Switch Internal Circuit

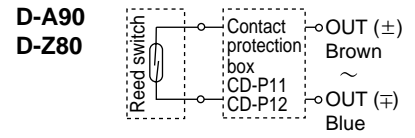
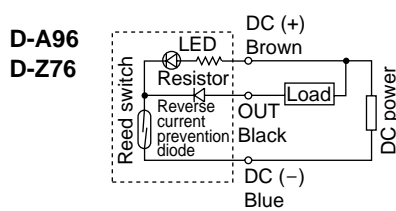
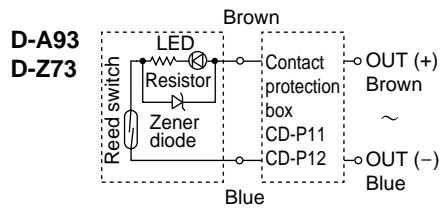

Solid State Switch Internal Circuit

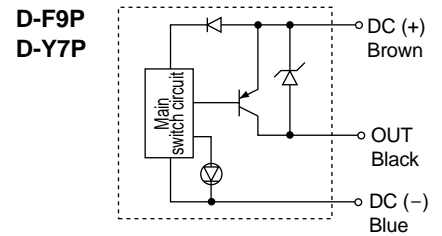
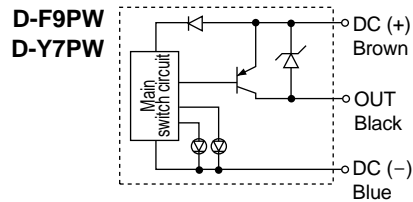
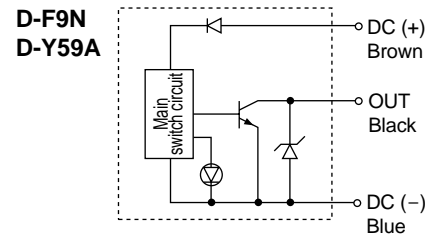
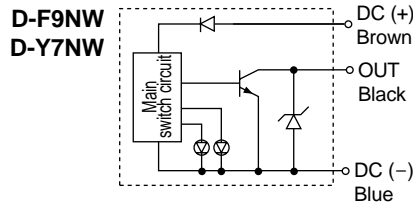

Indicator light

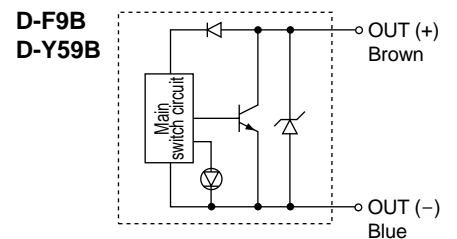
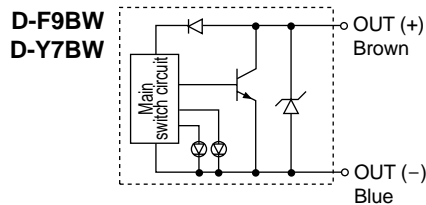
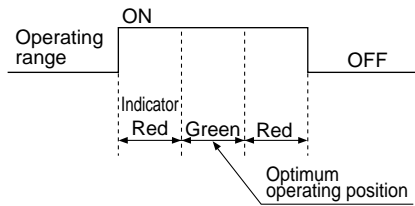

Contact Protection Box/CD-P11, CD-P12

<Applicable switches>

D-A9, Z7, Z8

The above auto switches do not have built-in contact protection circuits.

1. The operating load is an induction load.
2. The length of wiring to the load is 5m or more.
3. The load voltage is 100VAC.

A contact protection box should be used in any of the above conditions.

Contact protection box specifications

Part no.	CD-P11		CD-P12
Load voltage	100VAC or less	200VAC	24VDC
Max. load current	25mA	12.5mA	50mA

*Lead wire length — Switch contacts side 0.5m
Load connection side 0.5m



Internal circuit

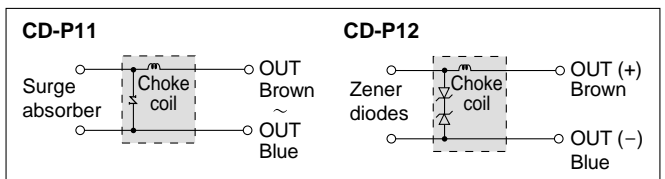

Dimensions

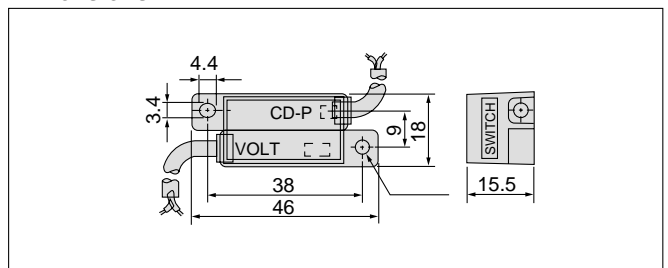

Connection

To connect a switch unit to a contact protection box, connect the lead wire from the side of the contact protection box marked SWITCH to the lead wire coming out of the switch unit. The switch unit should be kept as close as possible to the contact protection box with a lead wire that is no more than 1 meter in length.

Auto Switch Connections and Examples

Basic Wiring

Solid state 3-wire, NPN

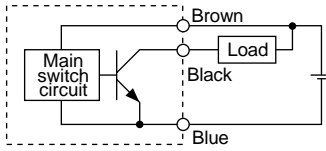

(Power supplies for switch and load are separate.)

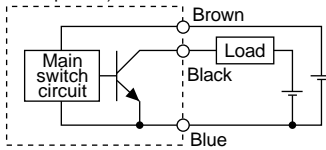

Solid state 3-wire, PNP

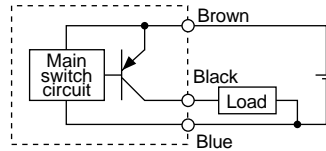

2-wire

<Solid state>

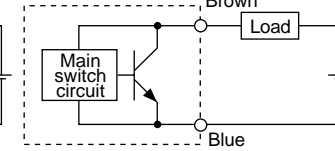

2-wire

<Reed switch>

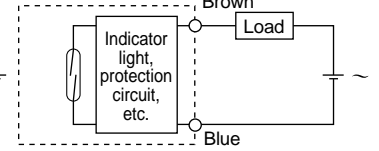

Examples of Connection to PLC

Sink input specifications 3-wire, NPN

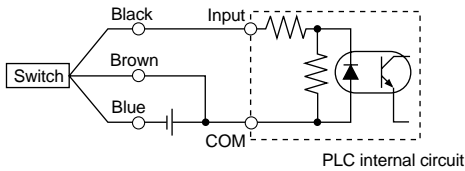

Source input specifications 3-wire, PNP

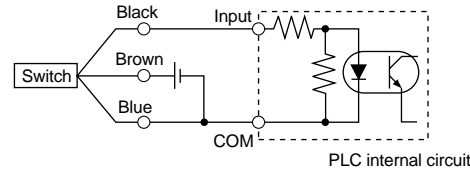

Connect according to the applicable PLC input specifications, as the connection method will vary depending on the PLC input specifications.

2-wire

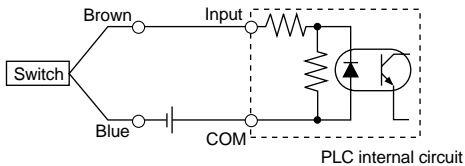

2-wire

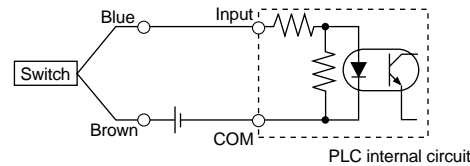

Connection Examples for AND (Series) and OR (Parallel)

3-wire

AND connection for NPN output (using relays)

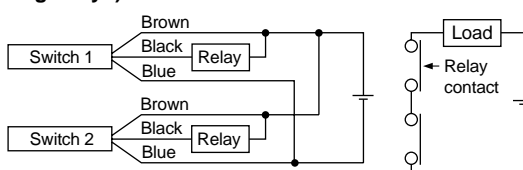

AND connection for NPN output (performed with switches only)

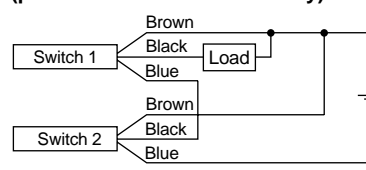

OR connection for NPN output

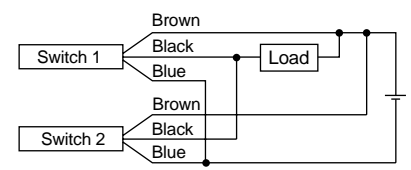

The indicator lights will light up when both switches are turned ON.

2-wire with 2 switch AND connection

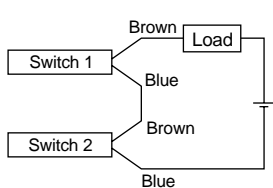

When two switches are connected in series, a load may malfunction because the load voltage will decline when in the ON state. The indicator lights will light up if both of the switches are in the ON state.

$$\begin{aligned} \text{Load voltage at ON} &= \text{Power supply voltage} - \text{Internal voltage drop} \times 2 \text{ pcs.} \\ &= 24\text{V} - 4\text{V} \times 2 \text{ pcs.} \\ &= 16\text{V} \end{aligned}$$

Example: Power supply is 24VDC
Internal voltage drop in switch is 4V

2-wire with 2 switch OR connection

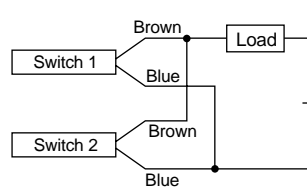

<Solid state>

When two switches are connected in parallel, malfunction may occur because the load voltage will increase when in the OFF state.

<Reed switch>

Because there is no current leakage, the load voltage will not increase when turned OFF. However, depending on the number of switches in the ON state, the indicator lights may sometimes dim or not light up, because of dispersion and reduction of the current flowing to the switches.

$$\begin{aligned} \text{Load voltage at OFF} &= \text{Leakage current} \times 2 \text{ pcs.} \times \text{Load impedance} \\ &= 1\text{mA} \times 2 \text{ pcs.} \times 3\text{k}\Omega \\ &= 6\text{V} \end{aligned}$$

Example: Load impedance is 3kΩ
Leakage current from switch is 1mA

Series CY3B/CY3R

Made to Order Specifications

Contact SMC for detailed specifications, lead times and prices.

Symbol	Contents	Model	Bore size (mm)				
			15	20	25	32	40
-XB11	Long stroke (2001mm and up)	CY3B					
-XB13	Low speed cylinder (7 to 50mm/s)	CY3B	●	●	●	●	●
-X116	Hydro specifications	CY3B			●	●	●
		CY3R			●	●	●
-X132	Axial ports	CY3B	●	●	●	●	●
-X160	High speed specifications	CY3B		●	●	●	●
		CY3R		●	●	●	●
-X168	Helical insert thread specifications	CY3B		●	●	●	●
		CY3R		●	●	●	●
-X206	Added mounting tap positions for slider	CY3B	●	●	●	●	●
-X210	Oil-free exterior specifications	CY3B	●	●	●	●	●
-X322	Outside of cylinder tube with hard chrome plating	CY3B	●	●	●	●	●
		CY3R	●	●	●	●	●
-X324	Oil-free exterior specifications (with dust seal)	CY3B	●	●	●	●	●
-XC57	With floating joint	CY3B	●	●	●	●	●
		CY3R	●	●	●	●	●

Series CY3B/CY3R Made to Order Specifications 1

Contact SMC for detailed specifications, lead times and prices.

1 Long stroke (2001mm and up) Symbol -XB11

CY3B Bore size Port thread type Stroke -XB11
↓
 Long stroke (2001mm to 3000mm)

Specifications

Applicable series	CY3B
Bore size	ø25 to ø40
Applicable stroke	2001st to 3000st

Note 1) If the stroke exceeds 3000 mm, use XB11 specification of series CY1B.

2 Low speed (7 to 50mm/s) specifications Symbol -XB13

CY3B Bore size Port thread type Stroke -XB13
↓
 Very low speed (7 to 50mm/s) specifications

There is no sticking and slipping even at very low drive speeds of 7 to 50mm/s. Furthermore, there is no lurching at start up, allowing smooth drive through the entire stroke.

Specifications

Applicable series	CY3B
Bore size	ø15 to ø40
Piston speed	7 to 50 mm/s

3 Hydro specifications Symbol -X116

CY3B Bore size Port thread type Stroke -X116
 CY3R
↓
 Hydro specifications

Suitable for precision low speed feeding, intermediate stopping and skip feeding of the cylinder.

Specifications

Applicable series	CY3B/CY3R
Bore size	ø25 to ø40
Fluid	Turbine oil
Piston speed	15 to 300mm/s

Note 1) Only piping on both sides is available with CY3R.

Note 2) When performing intermediate stops with an air-hydro circuit, set the kinetic energy of the load so that it does not exceed the allowable value. (Regarding the allowable value, refer to the section "Intermediate stops" for each series.)

4 Axial ports Symbol -X132

CY3B Bore size Port thread type Stroke -X132
↓
 Axial ports

The air supply port has been changed to an axial position on the head cover.

Specifications

Applicable series	CY3B
Bore size	ø15 to ø40

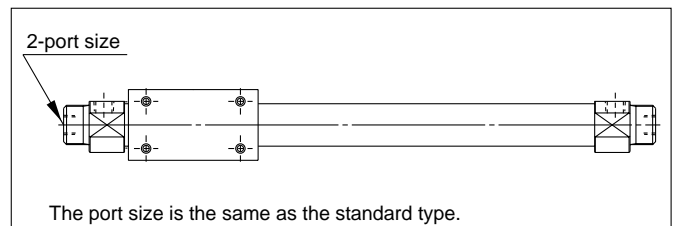

5 High speed specifications Symbol -X160

CY3B Bore size Port thread type Stroke -X160
 CY3R
↓
 High speed specifications

Makes possible high speed piston drive of 1500mm/s (without load).

Specifications

Applicable series	CY3B/CY3R
Bore size	ø20 to ø40
Piston speed (no load)	1500mm/s

Note 1) When operating this cylinder at high speed, a shock absorber must be provided.

Note 2) Only piping on both sides is available with CY3R.

6 Helical insert thread specifications Symbol -X168

CY3B Bore size Port thread type Stroke -X168
 CY3R
↓
 Helical insert thread specifications

The standard mounting threads have been changed to helical insert thread specifications.

Specifications

Applicable series	CY3B/CY3R
Bore size	ø20 to ø40

Series CY3B/CY3R

Made to Order Specifications 2

Contact SMC for detailed specifications, lead times and prices.

7 Added mounting tap positions for slider Symbol -X206

CY3B Bore size Port thread type Stroke -X206

Added mounting tap positions for slider

Mounting taps have been added on the surface opposite the standard positions.

Specifications

Applicable series	CY3B
Bore size	ø15 to ø40

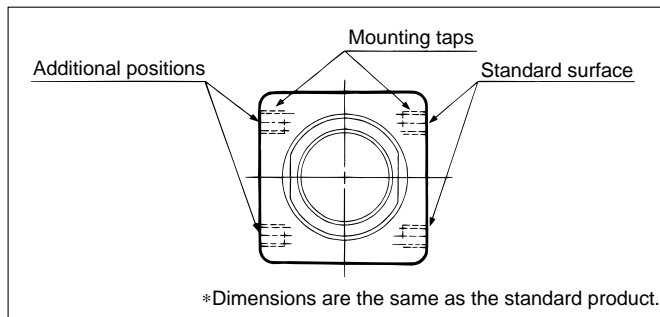

8 Oil-free exterior specifications Symbol -X210

CY3B Bore size Port thread type Stroke -X210

Oil-free exterior specifications

Suitable for environments where oils are not tolerated. A scraper is not installed. A separate version -X324 (with felt) has been prepared for cases in which dust, etc. is scattered throughout the environment.

Specifications

Applicable series	CY3B
Bore size	ø15 to ø40

Construction

CY3B

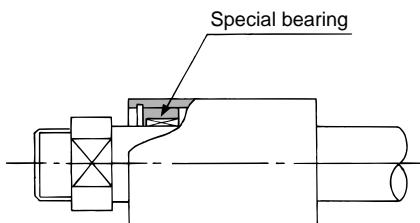

9 Outside of cylinder tube with hard chrome plating Symbol -X322

CY3B Bore size Port thread type Stroke -X322
CY3R

Outside of cylinder tube with hard chrome plating

The outside of the cylinder tube has been plated with hard chromium, reducing wear on the bearings.

Specifications

Applicable series	CY3B/CY3R
Bore size	ø15 to ø40

*Be sure to provide shock absorption measures at the stroke end.

Construction

CY3B

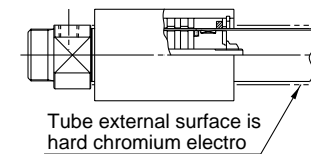

CY3R

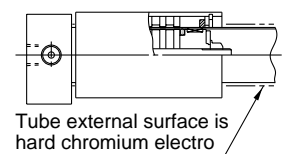

10 Oil-free exterior specifications (with dust seal) Symbol -X324

CY3B Bore size Port thread type Stroke -X324

Oil-free exterior specifications (with dust seal)

This unit has oil-free exterior specifications, with a felt dust seal provided on the cylinder body.

Specifications

Applicable series	CY3B
Bore size	ø15 to ø40

Construction

CY3B

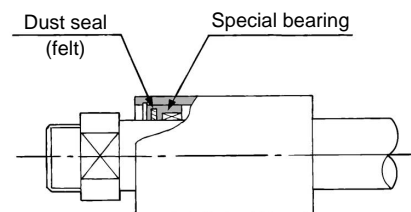

Series CY3B/CY3R

Made to Order Specifications 3

Contact SMC for detailed specifications, lead times and prices.

11 With floating joint (CY3B)

Symbol
-XC57

CY3B Bore size Port thread type Stroke XC57

With floating joint

Specifications

Bore size	ø15, ø20, ø25, ø32, ø40
-----------	-------------------------

Note) Since the body of this cylinder is designed for connection with a floating joint, and cannot be connected to the bodies of standard products, contact SMC if necessary.

A special floating joint is added to the Series CY3B, and the number of connections to the guide on the other axis (the load side) is reduced. The attachment of the bolt to the floating joint and the load is not limited to the top or bottom.

Dimensions

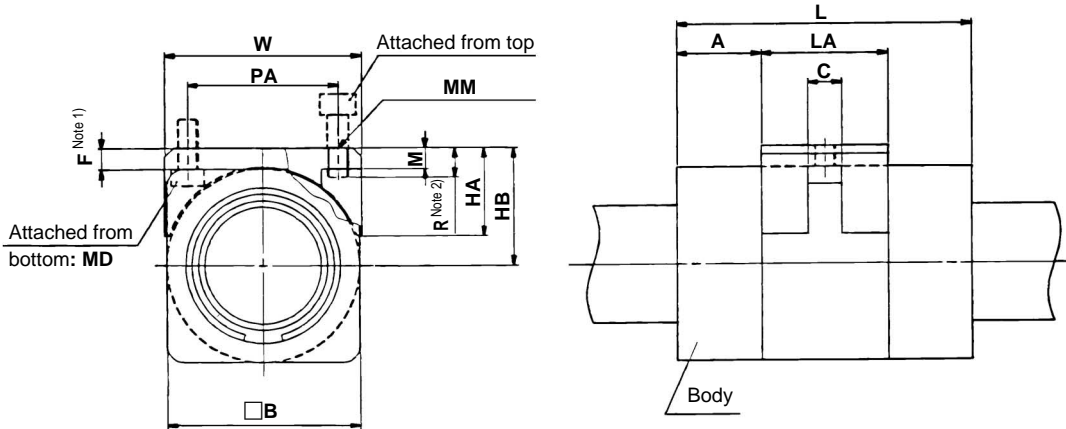

Model	A	B	C	F ^{Note 1)}	HA	HB	L	LA	MM	MD	M	PA	R ^{Note 2)}	W
CY3B15	16	35	6.5	5.5	16.5	23	57	25	M4 x 0.7	M3	4	25	6	36
CY3B20	18	36	6.5	5.5	17	23.5	66	30	M4 x 0.7	M3	4	27	6	37
CY3B25	20	46	8.0	5.5	21	28.5	70	30	M5 x 0.8	M4	5	36	7	47
CY3B32	22.5	60	9.5	6.0	27.5	36	80	35	M6 x 1.0	M5	6	47	8	61
CY3B40	26	70	9.5	6.0	28.5	41	92	40	M6 x 1.0	M5	6	55	8	71

Note 1) Dimension F provides a clearance of 1mm between the body and the floating joint, but does not consider dead weight deflection of the cylinder tube, etc. When put into operation, an appropriate value should be set which considers dead weight deflection and alignment variations with respect to the other axis. (Refer to the dead weight deflection table on page 5.)

Note 2) Use caution when attached from the top and operated at or above dimension R, because the end of the screw will contact the body, and floating cannot be maintained in some cases.

Series CY3B/CY3R

Made to Order Specifications 4

Contact SMC for detailed specifications, lead times and prices.

12 With floating joint (CY3R)

Symbol
-XC57

CY3R Bore size Port thread type Stroke -XC57

With floating joint

Specifications

Bore size	ø15, ø20, ø25, ø32, ø40
-----------	-------------------------

Note) Since the body of this cylinder is designed for connection with a floating joint, and cannot be connected to the bodies of standard products, contact SMC if necessary.

A special floating joint is added to the Series CY3R, and the number of connections to the guide on the other axis (the load side) is reduced. The attachment of the bolt to the floating joint and the load is not limited to the top or bottom.

Dimensions

ø15

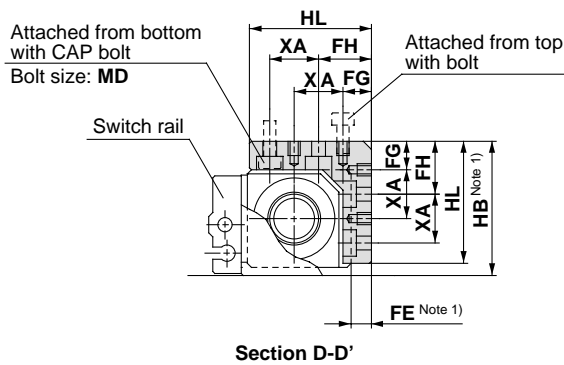

Section D-D'

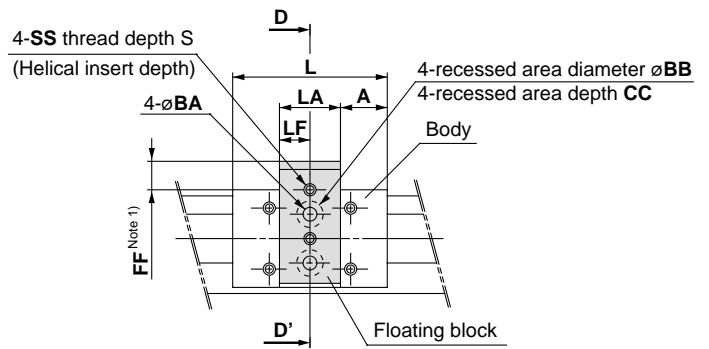

ø20, ø25, ø32, ø40

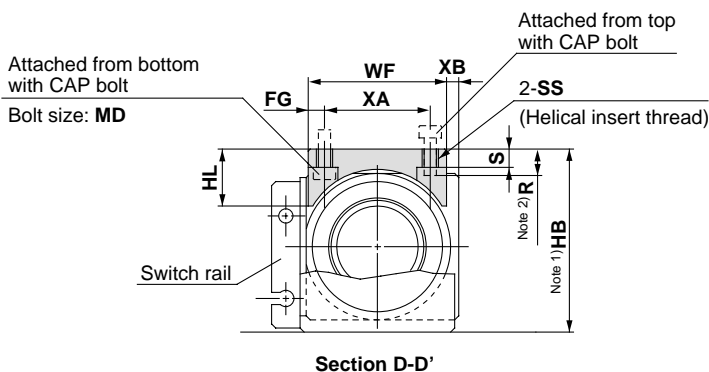

Section D-D'

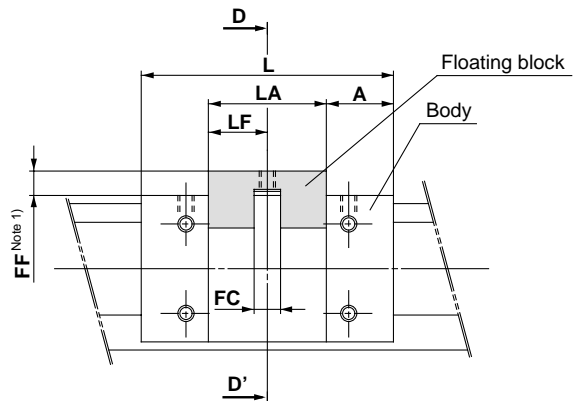

(mm)

Model	A	BA	BB	CC	FC	FE ^{Note 1)}	FF ^{Note 1)}	FG	FH	HB ^{Note 1)}	HL	L	LA	LF	MD	R ^{Note 2)}	S	SS	WF	XA	XB
CY3R□15	18	4.5	8	4.4	—	4.5	6.5	7.5	14.5	38.5	35.5	53	17	8.5	M4	—	4.5	M4 x 0.7	—	14	—
CY3R□20	16.5	—	—	—	6.5	—	6	4	—	45	14	62	29	14.5	M3	7	4.5	M4 x 0.7	34	26	3
CY3R□25	20.5	—	—	—	8	—	7	4	—	51	17	70	29	14.5	M4	8	5.5	M5 x 0.8	39	31	3
CY3R□32	21	—	—	—	9.5	—	7.5	4.5	—	62.5	22	76	34	17	M5	10	6.5	M6 x 1	50	41	3
CY3R□40	25.5	—	—	—	9.5	—	7.5	7.5	—	74.5	28	90	39	19.5	M5	10	6.5	M6 x 1	60	45	3

Note 1) FE, FF and HB provide a clearance of 1mm between the body and the floating joint, but do not consider dead weight deflection of the cylinder tube, etc. When put into operation, an appropriate value should be set which considers dead weight deflection an alignment variations with respect to the other axis. (Refer to the dead weight deflection table on page 5.)

Note 2) Use caution when attached from the top and operated at or above dimension R, because the end of the screw will contact the body, and floating cannot be maintained in some cases.



Series *CY3B/CY3R* Safety Instructions

These safety instructions are intended to prevent a hazardous situation and/or equipment damage. These instructions indicate the level of potential hazard by a label of "**Caution**", "**Warning**" or "**Danger**". To ensure safety, be sure to observe ISO 4414 Note 1), JIS B 8370 Note 2) and other safety practices.

 **Caution** : Operator error could result in injury or equipment damage.

 **Warning** : Operator error could result in serious injury or loss of life.

 **Danger** : In extreme conditions, there is a possible result of serious injury or loss of life.

Note 1) ISO 4414 : Pneumatic fluid power – Recommendations for the application of equipment to transmission and control systems.

Note 2) JIS B 8370 : General Rules for Pneumatic Equipment.

Warning

1. The compatibility of pneumatic equipment is the responsibility of the person who designs the pneumatic system or decides its specifications.

Since the products specified here are used in various operating conditions, their compatibility for the specific pneumatic system must be based on specifications or after analysis and/or tests to meet your specific requirements.

2. Only trained personnel should operate pneumatically operated machinery and equipment.

Compressed air can be dangerous if handled incorrectly. Assembly, handling or repair of pneumatic systems should be performed by trained and experienced operators.

3. Do not service machinery/equipment or attempt to remove components until safety is confirmed.

1. Inspection and maintenance of machinery/equipment should only be performed after confirmation of safe locked-out control positions.
2. When equipment is to be removed, confirm the safety process as mentioned above. Cut the supply pressure for this equipment and exhaust all residual compressed air in the system.
3. Before machinery/equipment is restarted, take measures to prevent shooting-out of cylinder piston rod, etc. (Bleed air into the system gradually to create back-pressure.)

4. Contact SMC if the product is to be used in any of the following conditions:

1. Conditions and environments beyond the given specifications, or if product is used outdoors.
2. Installation on equipment in conjunction with atomic energy, railway, air navigation, vehicles, medical equipment, food and beverages, recreation equipment, emergency stop circuits, press applications, or safety equipment.
3. An application which has the possibility of having negative effects on people, property, or animals, requiring special safety analysis.



Series CY3B/CY3R Actuator Precautions 1

Be sure to read before handling.

Precautions on Design

Warning

1. **There is a danger of sudden action by air cylinders if sliding parts of machinery are twisted, etc., and changes in forces occur.**

In such cases, human injury may occur; e.g., by catching hands or feet in the machinery, or damage to the machinery itself may occur. Therefore, the machine should be designed to avoid such dangers.

2. **A protective cover is recommended to minimize the risk of personal injury.**

If a stationary object and moving parts of a cylinder are in close proximity, personal injury may occur. Design the structure to avoid contact with the human body.

3. **Securely tighten all mounting parts and connecting parts so that they will not become loose.**

Especially when a cylinder operates with high frequency or is installed where there is a lot of vibration, ensure that all parts remain secure.

4. **A deceleration circuit or shock absorber, etc., may be required.**

When a driven object is operated at high speed or the load is heavy, a cylinder's cushion will not be sufficient to absorb the impact. Install a deceleration circuit to reduce the speed before cushioning, or install an external shock absorber to relieve the shock. In this case, the rigidity of the machinery should also be examined.

5. **Consider a possible drop in operating pressure due to a power outage, etc.**

When a cylinder is used in a clamping mechanism, there is a danger of work pieces dropping if there is a decrease in clamping force due to a drop in circuit pressure caused by a power outage, etc. Therefore, safety equipment should be installed to prevent damage to machinery and/or human injury. Suspension mechanisms and lifting devices also require consideration for drop prevention.

6. **Consider a possible loss of power source.**

Measures should be taken to protect against human injury and equipment damage in the event that there is a loss of power to equipment controlled by air pressure, electricity or hydraulics, etc.

7. **Design circuitry to prevent sudden lurching of driven objects.**

When a cylinder is driven by an exhaust center type directional control valve or when starting up after residual pressure is exhausted from the circuit, etc., the piston and its driven object will lurch at high speed if pressure is applied to one side of the cylinder because of the absence of air pressure inside the cylinder. In such cases, human injury may occur; e.g., by catching hands or feet in the machinery, or damage to the machinery itself may occur. Therefore, equipment should be selected and circuits designed to prevent sudden lurching.

8. **Consider emergency stops.**

Design so that human injury and/or damage to machinery and equipment will not be caused when machinery is stopped by a safety device under abnormal conditions, a power outage or a manual emergency stop.

9. **Consider the action when operation is restarted after an emergency stop or abnormal stop.**

Design the machinery so that human injury or equipment damage will not occur upon restart of operation. When the cylinder has to be reset at the starting position, install safe manual control equipment.

Selection

Warning

1. **Confirm the specifications.**

The products advertised in this catalog are designed according to use in industrial compressed air systems. If the products are used in conditions where pressure, temperature, etc., are out of specification, damage and/or malfunction may be caused. Do not use in these conditions. (Refer to specifications.)

Consult SMC if you use a fluid other than compressed air.

2. **Intermediate stops.**

When intermediate stopping of a cylinder piston is performed with a 3 position closed center type directional control valve, it is difficult to achieve stopping positions as accurate and minute as with hydraulic pressure due to the compressibility of air.

Furthermore, since valves and cylinders, etc., are not guaranteed for zero air leakage, it may not be possible to hold a stopped position for an extended period of time. Contact SMC in case it is necessary to hold a stopped position for an extended period.

Caution

1. **Operate within the limits of the maximum usable stroke.**

Refer to the selection procedures for the type of air cylinder to be used for the maximum usable stroke.

2. **Operate the piston within a range such that collision damage will not occur at the stroke end.**

Operate within a range such that damage will not occur when the piston having inertial force stops by striking the cover at the stroke end. Refer to the cylinder model selection procedure for the range within which damage will not occur.

3. **Use a speed controller to adjust the cylinder drive speed, gradually increasing from a low speed to the desired speed setting.**



Series CY3B/CY3R Actuator Precautions 2

Be sure to read before handling.

Mounting

⚠ Caution

1. Align carefully when connecting to a load having an external guide mechanism.

As the stroke becomes longer, variations in the center axis become larger. Consider using a connection method (floating mechanism) that is able to absorb these variations.

Moreover, consideration should be given to the exclusive floating joint (XC 57), which has been created for series CY3B and CY3R. (pages 23 and 24)

2. When an external guide is used, connect the external slider and the load in such a way that there is no interference at any point within the stroke.

3. Do not scratch or gouge the sliding parts of the cylinder tube by striking or grasping them with other objects.

Cylinder bores are manufactured to precise tolerances, so that even a slight deformation may cause malfunction.

4. Do not use until you can verify that equipment can operate properly.

Verify correct mounting by suitable function and leakage inspections after compressed air and power are connected following mounting, maintenance or conversions.

5. Instruction manual

The product should be mounted and operated after thoroughly reading the manual and understanding its contents.

Keep the instruction manual where it can be referred to as needed.

Piping

⚠ Caution

1. Preparation before piping

Before piping is connected, it should be thoroughly blown out with air (flushing) or washed to remove cutting chips, cutting oil and other debris from inside the pipe.

2. Wrapping of pipe tape

When screwing together pipes and fittings, etc., be certain that chips from the pipe threads and sealing material do not get inside the piping.

Also, when pipe tape is used, leave 1.5 to 2 thread ridges exposed at the end of the threads.

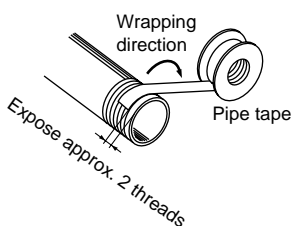

Lubrication

⚠ Caution

1. Lubrication of cylinder

The cylinder is lubricated at the factory and can be used without any further lubrication.

However, in the event that it will be lubricated, use class 1 turbine oil (without additives) ISO VG32.

Stopping lubrication later may lead to malfunction due to the loss of the original lubricant. Therefore, lubrication must be continued once it has been started.

Air Supply

⚠ Warning

1. Use clean air.

Do not use compressed air which includes chemicals, synthetic oils containing organic solvents, salt or corrosive gases, etc., as it can cause damage or malfunction.

⚠ Caution

1. Install air filters.

Install air filters at the upstream side of valves. The filtration degree should be 5µm or finer.

2. Install an air dryer, after cooler or water separator, etc.

Air that includes excessive drainage may cause malfunction of valves and other pneumatic equipment. To prevent this, install an air dryer, after cooler or water separator, etc.

3. Use the product within the specified range of fluid and ambient temperature.

Take measures to prevent freezing, since moisture in circuits can be frozen under 5°C, and this may cause damage to seals and lead to malfunction.

Refer to SMC's "Best Pneumatics vol. 4" catalog for further details on compressed air quality.

Operating Environment

⚠ Warning

1. Do not use in environments where there is a danger of corrosion.

Refer to the construction drawings regarding cylinder materials.

2. Provide a cover or other protection in dusty locations or where water, oil, etc., splash on the equipment.

Contact SMC in cases where dust or water, etc. will be scattered throughout the area.



Series CY3B/CY3R Actuator Precautions 3

Be sure to read before handling.

Maintenance

Warning

1. Maintenance should be performed according to the procedure indicated in the instruction manual.

If handled improperly, malfunction and damage of machinery or equipment may occur.

2. Removal of equipment, and supply/exhaust of compressed air.

When equipment is removed, first check measures to prevent dropping of driven objects and run-away of equipment, etc. Then cut off the supply pressure and electric power, and exhaust all compressed air from the system.

When machinery is restarted, proceed with caution after confirming measures to prevent cylinder lurching.

Caution

1. Drain flushing

Remove drainage from air filters regularly. (Refer to specifications.)



Series CY3R Auto Switch Precautions 1

Be sure to read before handling.

Design and Selection

Warning

1. Confirm the specifications.

Read the specifications carefully and use this product appropriately. The product may be damaged or malfunction if it is used outside the range of specifications of current load, voltage, temperature or impact.

2. Take precautions when multiple cylinders are used close together.

When multiple auto switch cylinders are used in close proximity, magnetic field interference may cause the switches to malfunction. Maintain a minimum cylinder separation of 40 mm. (When the allowable separation is indicated for each cylinder series, use the specified value.)

3. Pay attention to the length of time that a switch is ON at an intermediate stroke position.

When an auto switch is placed at an intermediate position of the stroke and a load is driven at the time the piston passes, the auto switch will operate, but if the speed is too great the operating time will be shortened and the load may not operate properly. The maximum detectable piston speed is:

$$V(\text{mm/s}) = \frac{\text{Auto switch operating range (mm)}}{\text{Load operating time (ms)}} \times 1000$$

4. Keep wiring as short as possible.

<Reed switch>

As the length of the wiring to a load gets longer, the rush current at switching ON becomes greater, and this may shorten the product's life. (The switch will stay ON all the time.)

- 1) For an auto switch without a contact protection circuit, use a contact protection box when the wire length is 5m or longer.

<Solid state switch>

- 2) Although wire length should not affect switch function, use wiring 100m or shorter.

5. Take precautions for the internal voltage drop of the switch.

<Reed switch>

- 1) Switches with an indicator light (Except D-A96 and Z76)
 - If auto switches are connected in series as shown below, take note that there will be a large voltage drop because of internal resistance in the light emitting diodes. (Refer to internal voltage drop in the auto switch specifications.)

[The voltage drop will be "n" times larger when "n" auto switches are connected.]

Even though an auto switch operates normally, the load may not operate.

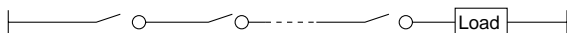

- In the same way, when operating below a specified voltage, although an auto switch may operate normally, the load may not operate. Therefore, the formula below should be satisfied after confirming the minimum operating voltage of the load.

$$\text{Supply voltage} - \text{Internal voltage drop of switch} > \text{Minimum operating voltage of load}$$

- 2) If the internal resistance of a light emitting diode causes a problem, select a switch without an indicator light (Model A90 and Z80).

<Solid state switch>

- 3) Generally, the internal voltage drop will be greater with a 2-wire solid state auto switch than with a reed switch. Take the same precautions as in 1).

Also, note that a 12VDC relay is not applicable.

6. Pay attention to leakage current.

<Solid state switch>

With a 2-wire solid state auto switch, current (leakage current) flows to the load to operate the internal circuit even when in the OFF state.

$$\text{Operating current of load (OFF condition)} > \text{Leakage current}$$

If the criteria given in the above formula are not met, it will not reset correctly (stays ON). Use a 3-wire switch if this specification will not be satisfied.

Moreover, leakage current flow to the load will be "n" times larger when "n" auto switches are connected in parallel.

7. Do not use a load that generates surge voltage.

<Reed switch>

If driving a load such as a relay that generates a surge voltage, use a contact protection box.

<Solid state switch>

Although a zener diode for surge protection is connected at the output side of a solid state auto switch, damage may still occur if the surge is applied repeatedly. When a load, such as a relay or solenoid valve, which generates surge is directly driven, use a type of switch with a built-in surge absorbing element.

8. Cautions for use in an interlock circuit.

When an auto switch is used for an interlock signal requiring high reliability, devise a double interlock system to avoid trouble by providing a mechanical protection function, or by also using another switch (sensor) together with the auto switch. Also perform periodic maintenance and confirm proper operation.

9. Ensure sufficient clearance for maintenance activities.

When designing an application, be sure to allow sufficient clearance for maintenance and inspections.



Series CY3R Auto Switch Precautions 2

Be sure to read before handling.

Mounting and Adjustment

Warning

1. Do not drop or bump.

Do not drop, bump or apply excessive impacts (300m/s² or more for reed switches and 1000m/s² or more for solid state switches) while handling.

Although the body of the switch may not be damaged, the inside of the switch could be damaged and cause a malfunction.

2. Do not carry a cylinder by the auto switch lead wires.

Never carry a cylinder by its lead wires. This may not only cause broken lead wires, but it may cause internal elements of the switch to be damaged by the stress.

3. Mount switches using the proper fastening torque.

When a switch is tightened beyond the range of tightening torque, the mounting screws, mounting bracket or switch may be damaged. On the other hand, tightening below the range of tightening torque may allow the switch to slip out of position. (Refer to switch mounting for each series regarding switch mounting, moving, and tightening torque, etc.)

4. Mount a switch at the center of the operating range.

Adjust the mounting position of an auto switch so that the piston stops at the center of the operating range (the range in which a switch is ON). (The mounting positions shown in a catalog indicate the optimum positions at stroke end.) If mounted at the end of the operating range (around the borderline of ON and OFF), operation may be unstable.

Wiring

Warning

1. Avoid repeatedly bending or stretching lead wires.

Broken lead wires will result from repeatedly applying bending stress or stretching force to the lead wires.

2. Be sure to connect the load before power is applied.

<2-wire type>

If the power is turned ON when an auto switch is not connected to a load, the switch will be instantly damaged because of excess current.

3. Confirm proper insulation of wiring.

Be certain that there is no faulty wiring insulation (contact with other circuits, ground fault, improper insulation between terminals, etc.). Damage may occur due to excess current flow into a switch.

4. Do not wire with power lines or high voltage lines.

Wire separately from power lines or high voltage lines, avoiding parallel wiring or wiring in the same conduit with these lines. Control circuits containing auto switches may malfunction due to noise from these other lines.

Wiring

Warning

5. Do not allow short circuit of loads.

<Reed switch>

If the power is turned ON with a load in a short circuit condition, the switch will be instantly damaged because of excess current flow into the switch.

<Solid state switch>

All models of PNP output type switches do not have built-in short circuit protection circuits. If loads are short circuited, the switches will be instantly damaged, as in the case of reed switches.

*Take special care to avoid reverse wiring with the brown power supply line and the black output line on 3-wire type switches.

6. Avoid incorrect wiring.

<Reed switch>

*A 24VDC switch with indicator light has polarity. The brown lead wire or terminal no. 1 is (+), and the blue lead wire or terminal no. 2 is (-).

1) If connections are reversed, a switch will operate, however, the light emitting diode will not light up.

Also note that a current greater than that specified will damage a light emitting diode and it will no longer operate.

Applicable model: D-A93

<Solid state switch>

1) If connections are reversed on a 2-wire type switch, the switch will not be damaged if protected by a protection circuit, but the switch will be in a normally ON state. However, note that the switch will be damaged if reversed connections are made while the load is in a short circuited condition.

*2) If connections are reversed (power supply line + and power supply line -) on a 3 wire type switch, the switch will be protected by a protection circuit. However, if the power supply line (+) is connected to the blue wire and the power supply line (-) is connected to the black wire, the switch will be damaged.

* Lead wire color changes

Lead wire colors of SMC switches have been changed in order to meet NECA Standard 0402 for production beginning September, 1996 and thereafter. Please refer to the tables provided. Special care should be taken regarding wire polarity during the time that the old colors still coexist with the new colors.

2-wire

	Old	New
Output (+)	Red	Brown
Output (-)	Black	Blue

3-wire

	Old	New
Power supply	Red	Brown
GND	Black	Blue
Output	White	Black

Solid state with diagnostic output

	Old	New
Power supply	Red	Brown
GND	Black	Blue
Output	White	Black
Diagnostic Output	Yellow	Orange

Solid state with latch type diagnostic output

	Old	New
Power supply	Red	Brown
GND	Black	Blue
Output	White	Black
Latch type diagnostic Output	Yellow	Orange



Series CY3R Auto Switch Precautions 3

Be sure to read before handling.

Operating Environment

Warning

1. Never use in an atmosphere of explosive gases.

The construction of auto switches is not intended to prevent explosion. Never use in an atmosphere with an explosive gas since this may cause a serious explosion.

2. Do not use in an area where a magnetic field is generated.

Auto switches will malfunction or magnets inside cylinders will become demagnetized.

3. Do not use in an environment where the auto switch will be continually exposed to water.

Although switches satisfy the IEC standard IP67 construction (JIS C 0920: watertight construction), do not use switches in applications where continually exposed to water splash or spray. Poor insulation or swelling of the potting resin inside switches may cause malfunction.

4. Do not use in an environment with oil or chemicals.

Consult SMC if auto switches will be used in an environment with coolant, cleaning solvent, various oils or chemicals. If auto switches are used under these conditions for even a short time, they may be adversely affected by improper insulation, malfunction due to swelling of the potting resin, or hardening of the lead wires.

5. Do not use in an environment with temperature cycles.

Consult SMC if switches are used where there are temperature cycles other than normal temperature changes, as they may be adversely affected internally.

6. Do not use in an environment where there is excessive impact shock.

<Reed switch>

When excessive impact (300m/s² or more) is applied to a reed switch during operation, the contact will malfunction and generate or cut off a signal momentarily (1ms or less). Consult SMC regarding the need to use a solid state switch depending upon the environment.

7. Do not use in an area where surges are generated.

<Solid state switch>

When there are units (solenoid type lifter, high frequency induction furnace, motor, etc.) which generate a large amount of surge in the area around cylinders with solid state auto switches, this may cause deterioration or damage to internal circuit elements of the switch. Avoid sources of surge generation and crossed lines.

8. Avoid accumulation of iron debris or close contact with magnetic substances.

When a large amount of ferrous debris such as machining chips or welding spatter is accumulated, or a magnetic substance (something attracted by a magnet) is brought into close proximity with an auto switch cylinder, it may cause auto switches to malfunction due to a loss of the magnetic force inside the cylinder.

Maintenance

Warning

1. Perform the following maintenance periodically in order to prevent possible danger due to unexpected auto switch malfunction.

1) Securely tighten switch mounting screws.

If screws become loose or the mounting position is dislocated, retighten them after readjusting the mounting position.

2) Confirm that there is no damage to lead wires.

To prevent faulty insulation, replace switches or repair lead wires, etc., if damage is discovered.

3) Confirm the lighting of the green light on the 2-color display type switch.

Confirm that the green LED is on when stopped at the established position. If the red LED is on, the mounting position is not appropriate. Readjust the mounting position until the green LED lights up.

Other

Warning

1. Consult SMC concerning water resistance, elasticity of lead wires, and usage at welding sites, etc.



Series CY3B/CY3R Specific Product Precautions 1

Be sure to read before handling.

Refer to pages 25 through 31 for safety instructions, actuator precautions and auto switch precautions.

Mounting

⚠ Caution

1. Take care to avoid nicks or other damage on the outside surface of the cylinder tube.

This can lead to damage of the scraper and wear ring, which in turn can cause malfunction.

2. Take care regarding rotation of the external slider.

Rotation should be controlled by connecting it to another shaft (linear guide, etc.).

3. Do not operate with the magnetic coupling out of position.

In case the magnetic coupling is out of position, push the external slider back into the correct position by hand at the end of the stroke (or correct the piston slider with air pressure).

4. The cylinder is mounted with bolts through the mounting holes in the end covers. Be sure they are tightened securely. (CY3R)

5. If gaps occur between the mounting surface and the end covers when mounting with bolts, perform shim adjustment using spacers, etc. so that there is no unreasonable stress. (CY3R)

6. Be sure that both end covers are secured to the mounting surface before operating the cylinder.

Avoid operation with the external slider secured to the surface.

7. Do not apply a lateral load to the external slider.

When a load is mounted directly to the cylinder, variations in the alignment of each shaft center cannot be assimilated, which results in the generation of a lateral load that can cause malfunction. The cylinder should be operated using a connection method which allows for assimilation of shaft alignment variations and deflection due to the cylinder's own weight. A drawing of a recommended mounting is shown in Figure 2.

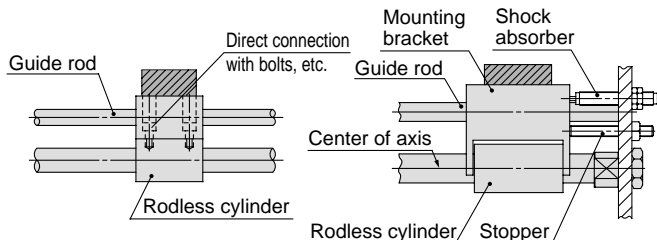

Variations in the load and cylinder shaft alignment cannot be assimilated, resulting in malfunction.

Figure 1. Incorrect mounting
Note) The drawing shows CY3B.

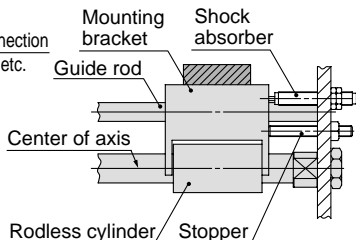

Shaft alignment variations are assimilated by providing clearance for the mounting bracket and cylinder. Moreover, the mounting bracket is extended above the cylinder shaft center, so that the cylinder is not subjected to moment.

Figure 2. Recommended mounting

Mounting

⚠ Caution

8. Use caution regarding the allowable load weight when operating in a vertical direction.

The allowable load weight when operating in a vertical direction (reference values on page 5) is determined by the model selection method, however, if a load greater than the allowable value is applied, the magnetic coupling may break and there is a possibility of dropping the load. When using this type of application, contact SMC regarding the operating conditions (pressure, load, speed, stroke, frequency, etc.).

Disassembly and Maintenance

⚠ Warning

1. Use caution as the attractive power of the magnets is very strong.

When removing the external slider and piston slider from the cylinder tube for maintenance, etc., handle with caution, since the magnets installed in each slider have very strong attractive power.

⚠ Caution

1. When reattaching the head covers after disassembly, confirm that they are tightened securely. (CY3B)

When disassembling, hold the wrench flat section of one head cover with a vise, and remove the other cover using a spanner or adjustable angle wrench on its wrench flat section. When retightening, first coat with Locktight (No. 542 red), and retighten 3 to 5° past the original position prior to removal.

2. Special tools are necessary for disassembly. (CY3R)

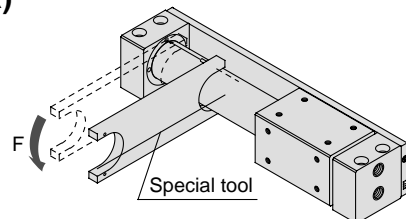

Special tool number list

No.	Applicable bore size (mm)
CYRZ-V	15, 20
CYRZ-W	25, 32, 40

3. Use caution when taking off the external slider, as the piston slider will be directly attracted to it.

When removing the external slider or piston slider from the cylinder tube, first force the sliders out of their magnetically coupled positions and then remove them individually while there is no longer any holding force. If they are removed when still magnetically coupled, they will be directly attracted to one another and will not come apart.

4. Do not disassemble the magnetic components (piston slider, external slider).

This can cause a loss of holding force and malfunction.

5. When disassembling to replace the seals and wear ring, refer to the separate disassembly instructions.



SMC'S GLOBAL MANUFACTURING, DISTRIBUTION AND SERVICE NETWORK

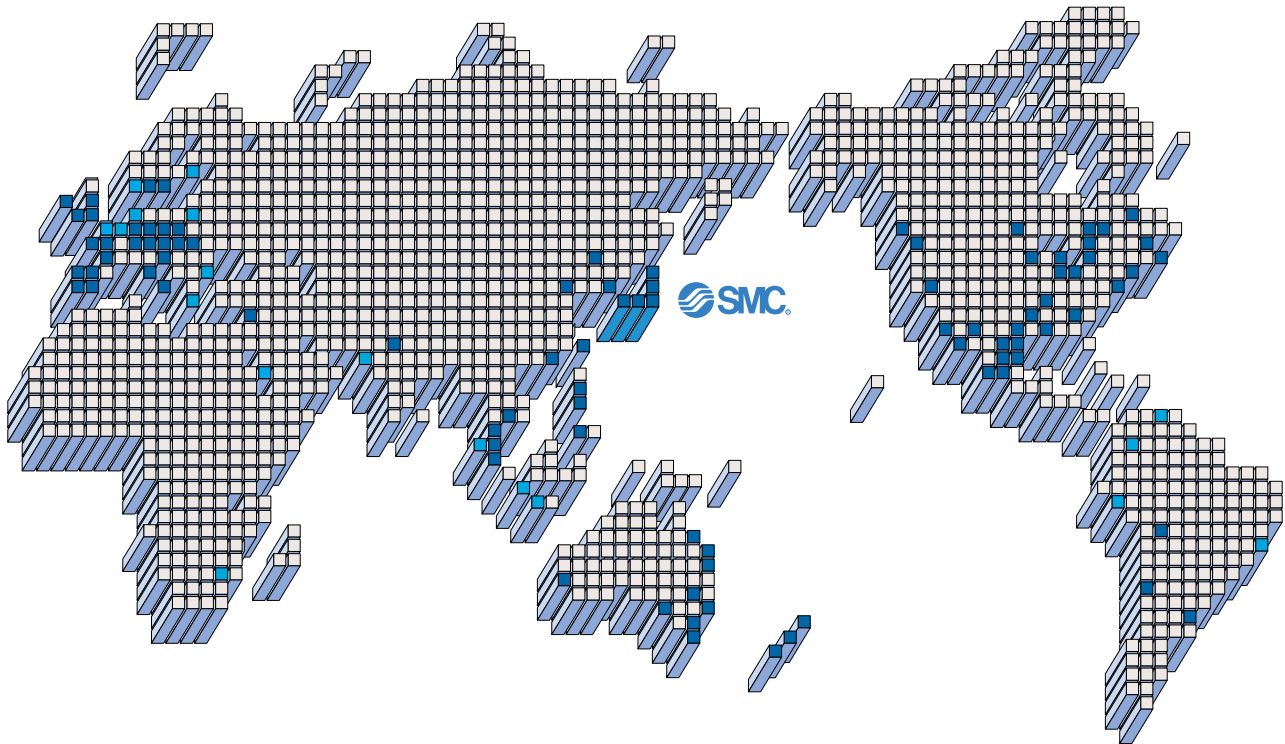

EUROPE

AUSTRIA

SMC Pneumatik GmbH

CZECH

SMC Industrial Automation CZ s.r.o.

DENMARK

SMC Pneumatik A/S

FINLAND

SMC Pneumatics Finland OY

FRANCE

SMC Pneumatique SA

GERMANY

SMC Pneumatik GmbH

HUNGARY

SMC Hungary Ipari Automatizálási Kft.

IRELAND

SMC Pneumatics (Ireland) Ltd.

ITALY

SMC Italia S.p.A.

LATVIA

SMC Pneumatics Latvia SIA

NETHERLANDS

SMC Pneumatics BV.

NORWAY

SMC Pneumatics Norway A/S

POLAND

SMC Industrial Automation Polska Sp.z.o.o.

ROMANIA

SMC Romania s.r.l.

RUSSIA

SMC Pneumatik LLC.

EUROPE

SLOVAKIA

SMC Priemyselná Automatizácia, s.r.o.

SLOVENIA

SMC Industrijska Avtomatika d.o.o.

SPAIN/PORTUGAL

SMC España, S.A.

SWEDEN

SMC Pneumatics Sweden AB

SWITZERLAND

SMC Pneumatik AG.

UK

SMC Pneumatics (U.K.) Ltd.

ASIA

CHINA

SMC (China) Co., Ltd.

HONG KONG

SMC Pneumatics (Hong Kong) Ltd.

INDIA

SMC Pneumatics (India) Pvt. Ltd.

MALAYSIA

SMC Pneumatics (S.E.A.) Sdn. Bhd.

PHILIPPINES

SMC Pneumatics (Philippines), Inc.

SINGAPORE

SMC Pneumatics (S.E.A.) Pte. Ltd.

SOUTH KOREA

SMC Pneumatics Korea Co., Ltd.

TAIWAN

SMC Pneumatics (Taiwan) Co., Ltd.

ASIA

THAILAND

SMC Thailand Ltd.

NORTH AMERICA

CANADA

SMC Pneumatics (Canada) Ltd.

MEXICO

SMC Corporation (Mexico) S.A. de C.V.

USA

SMC Corporation of America

SOUTH AMERICA

ARGENTINA

SMC Argentina S.A.

BOLIVIA

SMC Pneumatics Bolivia S.R.L.

BRAZIL

SMC Pneumaticos Do Brazil Ltda.

CHILE

SMC Pneumatics (Chile) S.A.

VENEZUELA

SMC Neumatica Venezuela S.A.

OCEANIA

AUSTRALIA

SMC Pneumatics (Australia) Pty. Ltd.

NEW ZEALAND

SMC Pneumatics (N.Z.) Ltd.

SMC Corporation

1-16-4 Shimbashi, Minato-ku, Tokyo 105-8659, JAPAN

Tel: 03-3502-2740 Fax: 03-3508-2480

URL <http://www.smcworld.com>

© 2002 SMC Corporation All Rights Reserved

1st printing April, 2002 D-DAD P-80 (YG)

This catalog is printed on recycled paper with concern for the global environment.

Specifications are subject to change without prior notice and any obligation on the part of the manufacturer.

Printed in Japan.