

# 27 SW220 / 320 / 420 Centrifugal Pump

## SW220 / 320 / 420 CENTRIFUGAL PUMP



- Liquid temperature : 0~70°C / 32~158°F
- HP range : 2~4HP / 1.5~3KW
- PH : 6~8
- Rated Speed : 2900 / 3450 rpm
- Protection class : IP55
- Maximum suction : 2M

### Features

- 1 · All the material is stainless steel. No rusty issue.
- 2 · Stainless steel close impeller & High head.
- 3 · It can endure light acid and alkali.

### Applications

- 1 · Gardening & Sprinkling
- 2 · Air conditioner, cleaning and heating system
- 3 · Fluid of PH6-8 pump application
- 4 · Pool system
- 5 · Filtration system
- 6 · Farm irrigation

### Specification

Model No.	Output		Outlet		Max Flow(LPM)	LPM Flow @ Head							Max Head(M)	Dimension	Weight
	HP	KW	mm	inch		6M	9M	12M	15M	18M	21M	24M		L x W x H(mm)	
SW-220(T)	2	1.5	50	2"	630	600	550	485	410	320	200	24	380 x 195 x 265	24	
SW-320(T)	3	2.2	50	2"	650	640	620	590	550	500	420	29	415 x 195 x 242	25	
SW-420(T)	4	3	50	2"	680	670	650	620	585	540	480	31	432 x 195 x 242	28	

### Dimension

Model	Dimension							
	L	L1	L2	L3	W	W1	H	H1
SW-220(T)	378	255	123	82	193	190	258	125
SW-320(T)	415	255	160	82	193	190	258	125
SW-420(T)	432	255	177	82	193	190	258	125

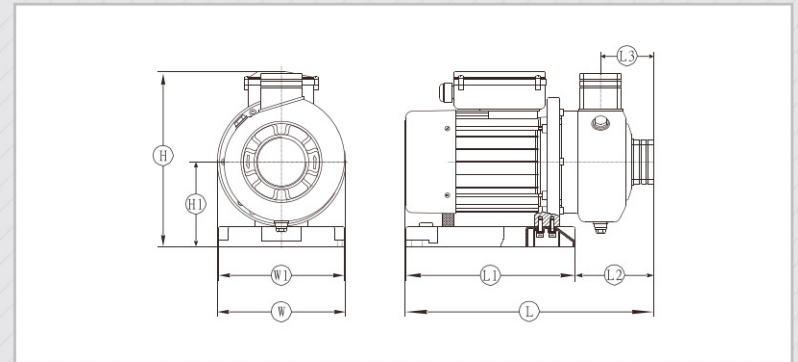

### Curve

