



Single-impeller, medium to high-flow rate centrifugal pumps with 2", 3" and 4" delivery openings. Mainly used in agriculture for flood and sprinkler irrigation, and water withdrawal from reservoirs or canals.

Construction features

Pump body	cast iron
Motor bracket	cast iron
Impeller	cast iron or brass (CSB)
Mechanical seal	ceramic-graphite-NBR
Motor shaft	stainless steel AISI 303 stainless steel AISI 416 (75÷120)
Liquid temperature	0 - 90 °C
Operating pressure	max 6 bar

Motor

	3- 230/400V - 50Hz
2 Poles induction motor	1- 230V - 50Hz (with thermal protection up to MEC 80)
Insulation class	F
Protection degree	IPX4

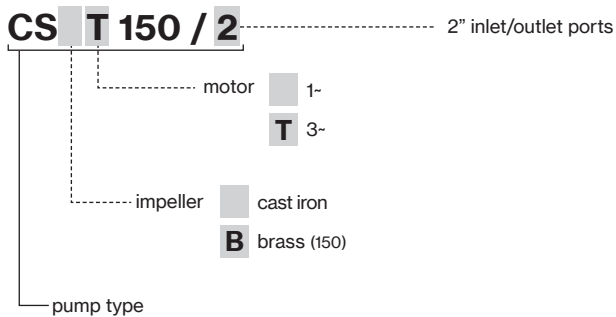

TYPE	LOTS			
	TRUCK		CONTAINER	
	PALLET (cm)	N° pumps	PALLET (cm)	N° pumps
CS 75/2÷120/2	90×110×145	65	90×110×195	91
CS 150/2-200/2	85×110×140	40	85×110×205	60
CS 200/3-300/3	85×110×150	30	85×110×180	60
CS 400/3÷550/4	80×120×150	30	80×120×180	60
CST 750/4-1000/4	100×120×140	18	100×120×185	24

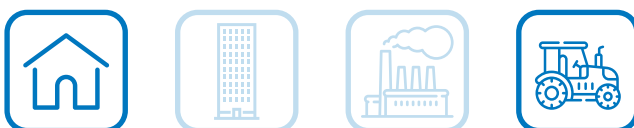

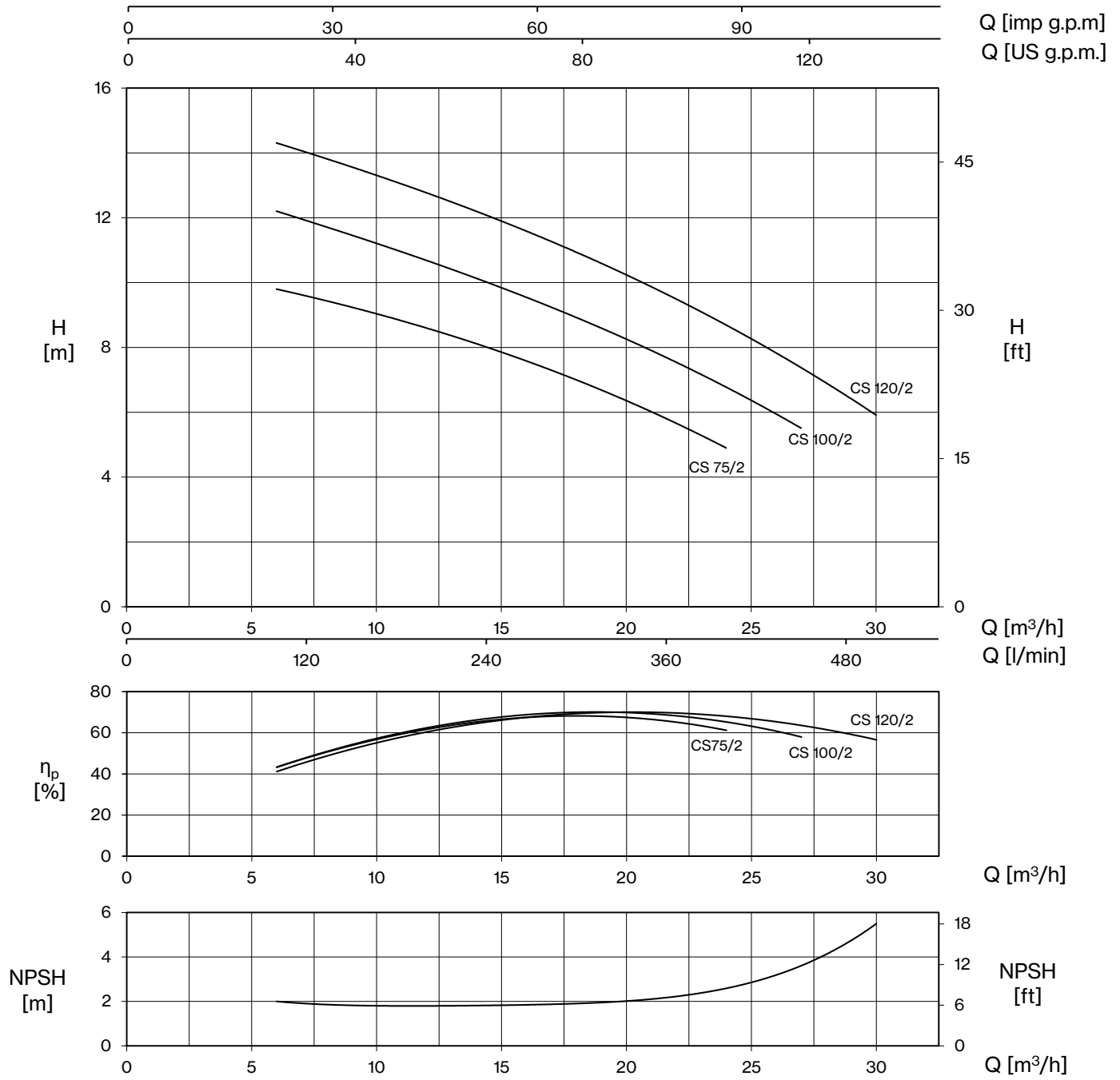

TYPE		P2		P1 (kW)		AMPERE		Q (m³/h - l/min)						
1~	3~					1~	3~	0	6	12	18	24	27	30
		0	100	200	300			400	450	500				
		HP	kW	1~	3~	1~ 230V 50 Hz	3~ 400V 50 Hz	H (m)						
CS 75/2	CST 75/2	0,8	0,59	0,8	0,7	3,5	1,3	10,1	9,8	8,6	7,0	4,9		
CS 100/2	CST 100/2	1	0,74	1	0,85	4,5	1,6	12,8	12,2	10,7	8,9	6,8	5,5	
CS 120/2	CST 120/2	1,2	0,9	1,2	1,1	5,4	2,0	15,0	14,3	12,8	10,9	8,7	7,4	5,9



CS

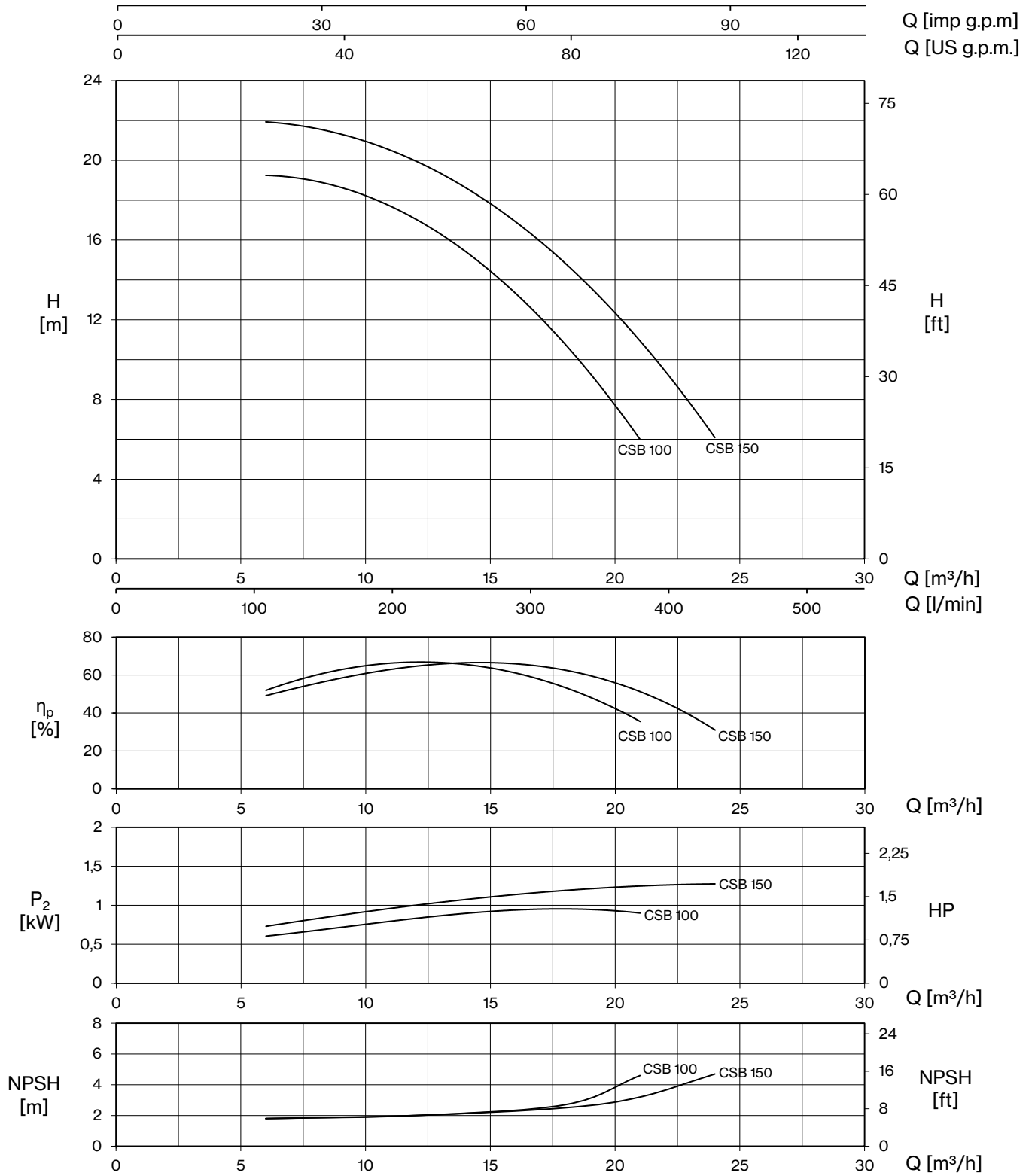

TYPE		P2		P1 (kW)		AMPERE		Q (m³/h - l/min)					
1~	3~					1~	3~	0	6	12	18	21	24
		HP	kW	1~	3~	1~ 230V 50 Hz	3~ 400V 50 Hz	0	100	200	300	350	400
CSB 100/2	-	1,5	1,1	1,3	-	6,1	-	18,8	19,2	17,1	10,8	6,0	
CSB 150/2	CSBT 150/2	1,8	1,3	1,6	1,5	7,4	3,5	21,6	21,9	19,9	15,0	10,8	6,1



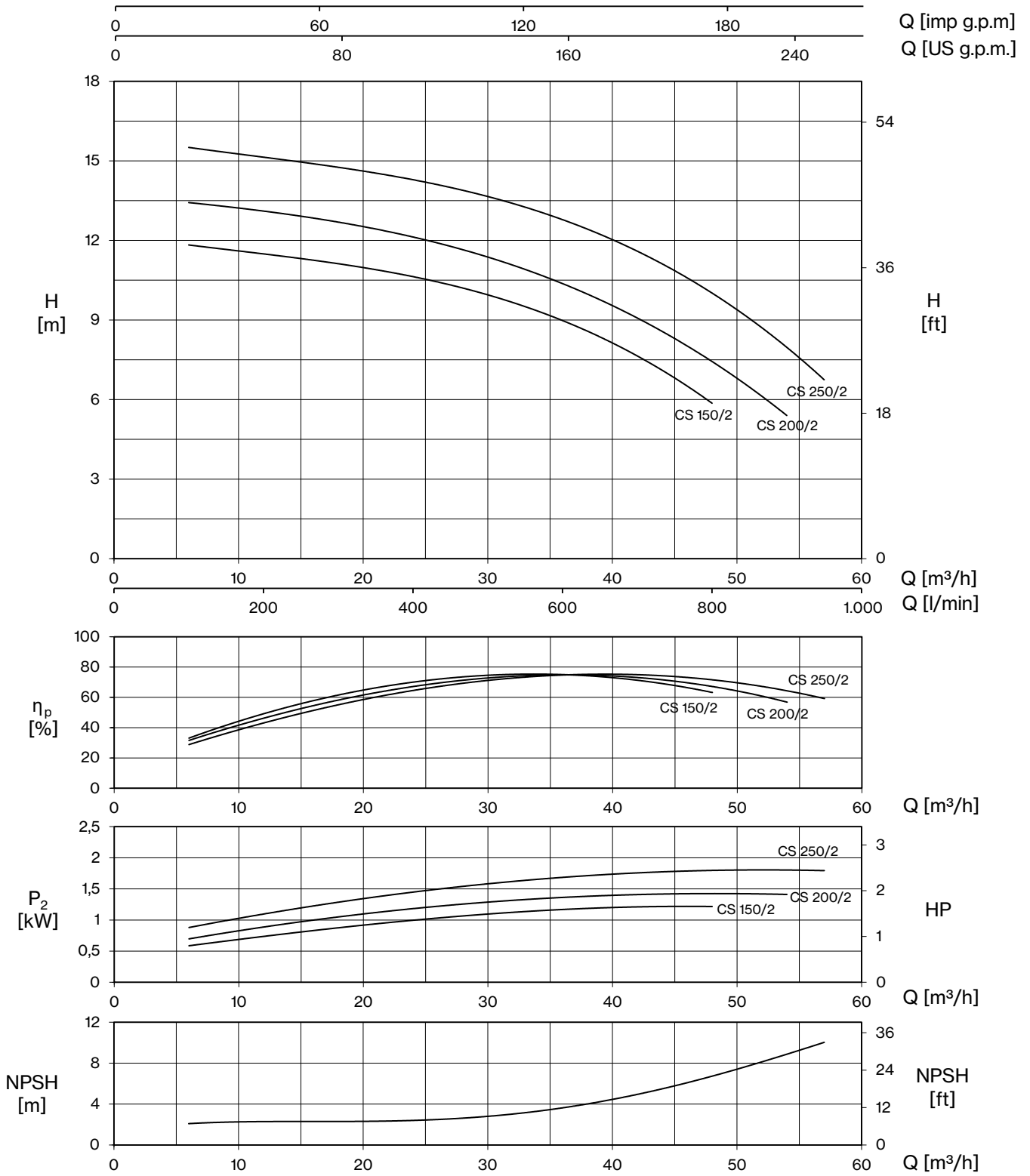

TYPE		P2		P1 (kW)		AMPERE		Q (m³/h - l/min)										
1~	3~					1~	3~	0	6	18	24	30	36	42	48	54	57	
		HP	kW	1~	3~	1~ 230V 50 Hz	3~ 400V 50 Hz	0	100	300	400	500	600	700	800	900	950	
								H (m)										
CS 150/2	CST 150/2	1,8	1,3	1,5	1,4	7,1	3,4	11,9	11,8	11,1	10,6	10,0	8,9	7,6	5,9			
CS 200/2	CST 200/2	2	1,5	1,7	1,7	8,0	3,6	13,5	13,4	12,6	12,1	11,4	10,4	9,1	7,3	5,4		
CS 250/2	CST 250/2	2,5	1,85	2,2	2,1	9,9	4,3	15,6	15,6	14,6	14,3	13,8	12,9	11,6	9,9	7,9	6,9	



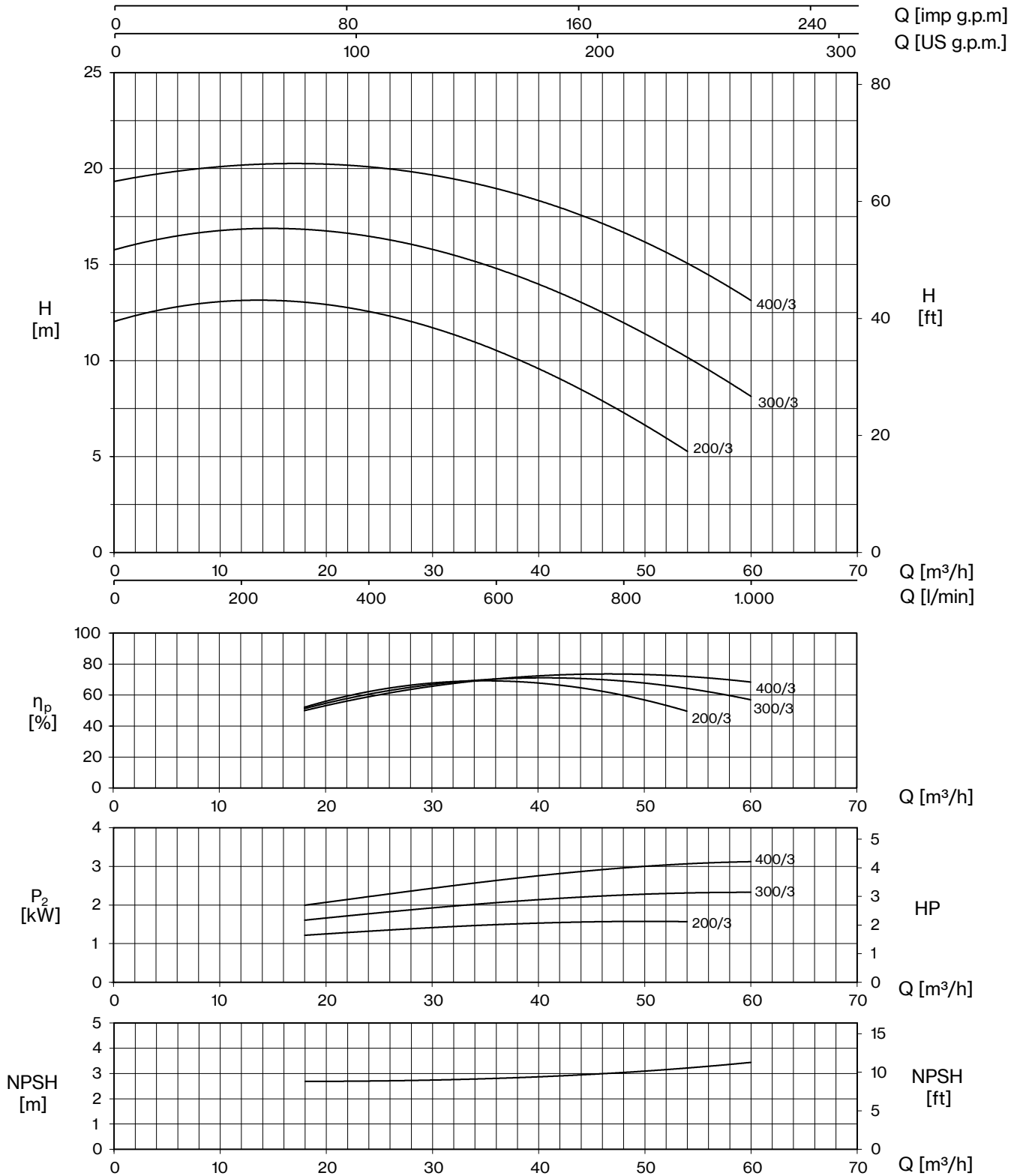

TYPE		P2		P1 (kW)		AMPERE		Q (m³/h - l/min)									
1~	3~	HP	kW	1~	3~	1~ 230V 50 Hz	3~ 400V 50 Hz	0	18	24	30	36	42	48	54	60	
								0	300	400	500	600	700	800	900	1000	
								H (m)									
CS 200/3	CST 200/3	2	1,5	1,9	1,9	8,9	3,5	12,0	13,0	12,6	11,8	10,6	9,0	7,2	5,3		
CS 300/3	CST 300/3	3	2,2	2,7	2,7	12,4	5	15,8	16,8	16,5	15,7	14,7	13,6	12,0	10,1	8,2	
-	CST 400/3	4	3	-	3,6	-	6,6	19,3	20,3	20,1	19,6	18,9	18,0	16,8	15,0	13,1	



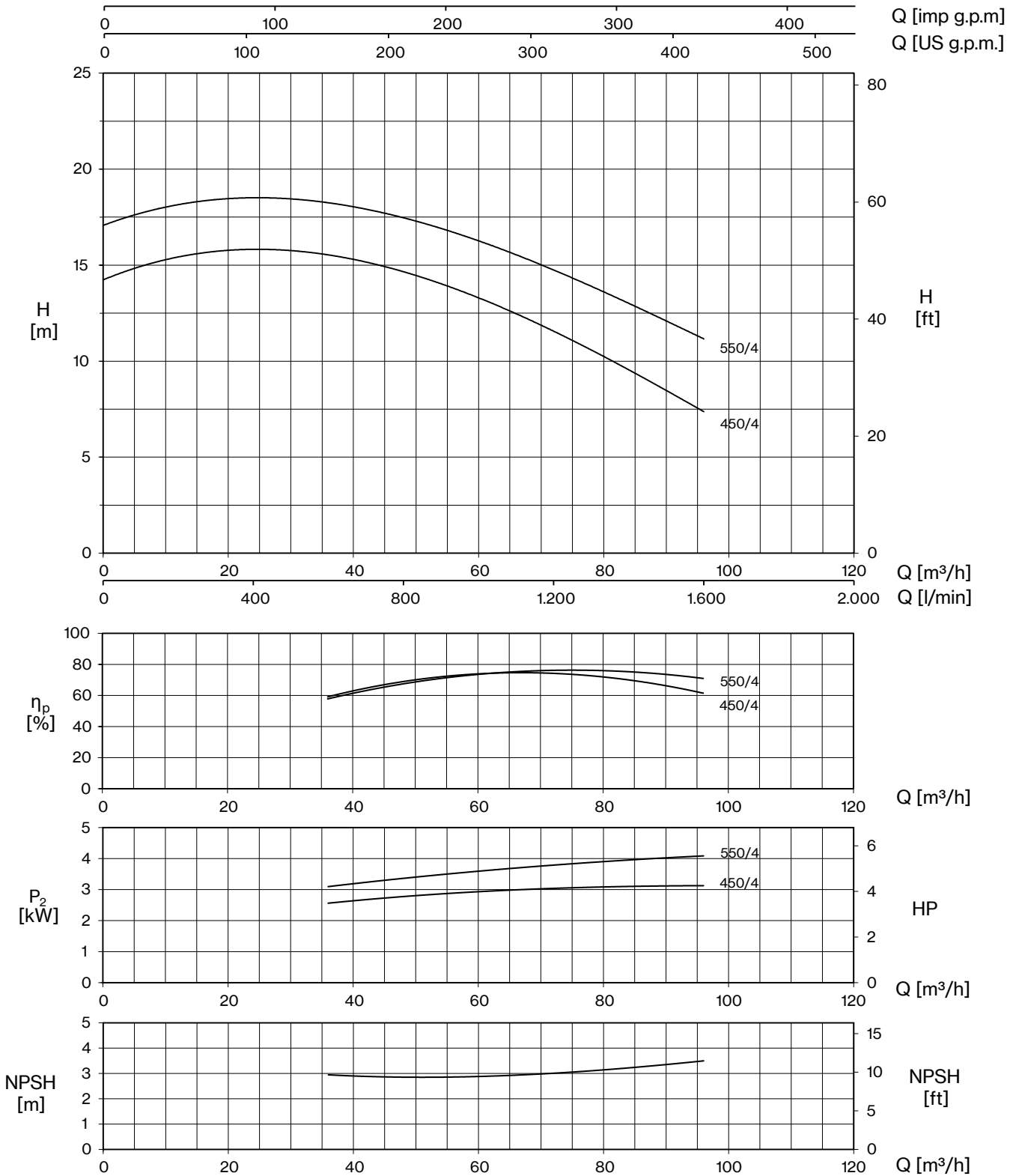

TYPE		P2		P1 (kW)		AMPERE		Q (m³/h - l/min)						
1~	3~	HP	kW	1~	3~	1~ 230V 50 Hz	3~ 400V 50 Hz	0	36	48	60	72	84	96
								0	600	800	1000	1200	1400	1600
		H (m)												
CS 450/4	CST 450/4	4	3	3,6	3,6	16,1	6,5	14,2	15,5	14,7	13,4	11,5	9,6	7,4
-	CST 550/4	5,5	4	-	4,7	-	8,5	17,1	18,3	17,4	16,3	14,7	13,1	11,1



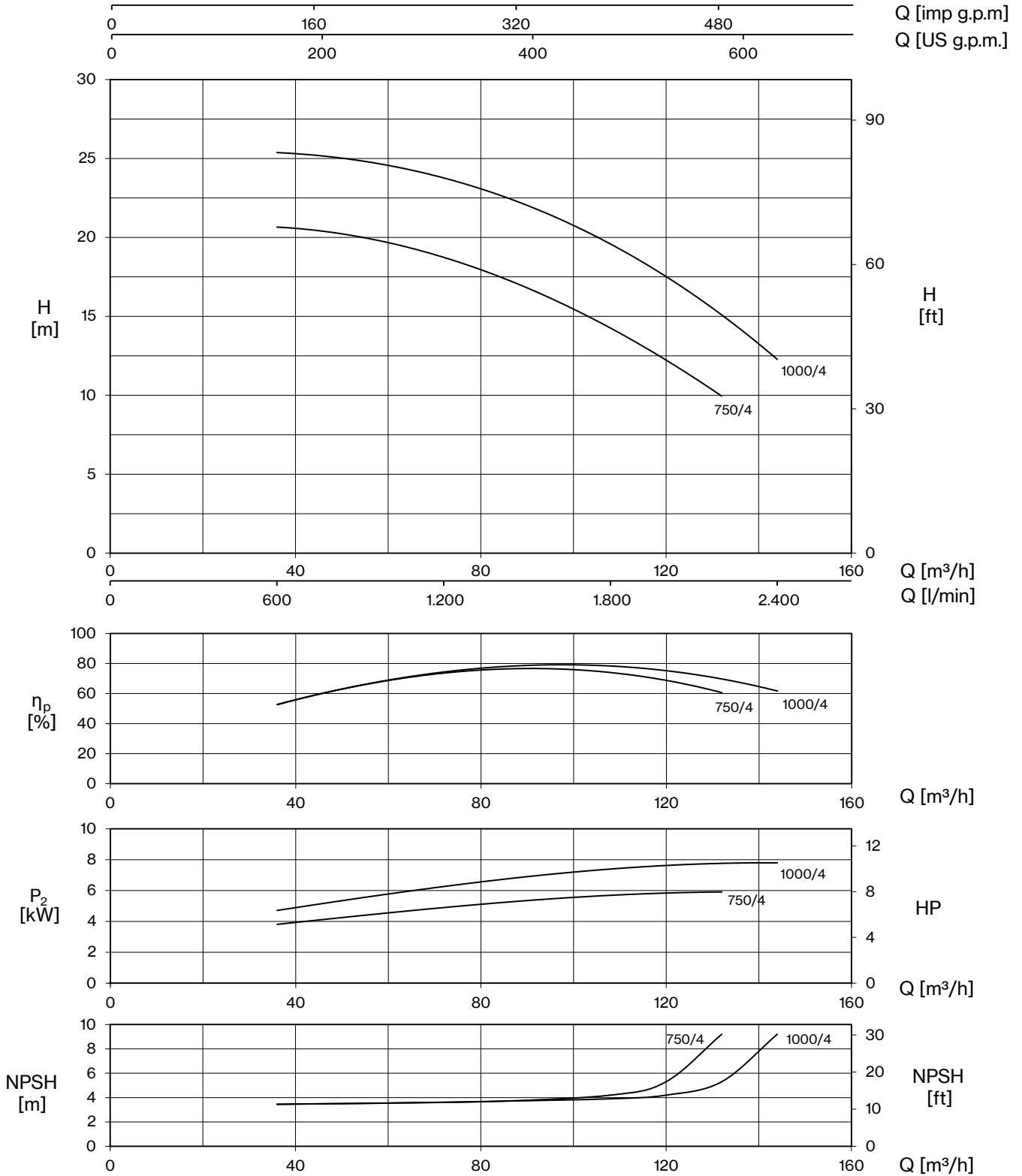



TYPE	P2		P1 (kW)	AMPERE	Q (m³/h - l/min)									
					0	36	48	60	84	108	120	132	144	
3~	HP	kW	3~	3- 400V 50 Hz	H (m)									
					0	600	800	1000	1400	1800	2000	2200	2400	
CST 750/4	7,5	5,5	6,7	11,6	18,9	20,6	20,4	19,7	17,4	14,3	12,3	9,9		
CST 1000/4	10	7,5	8,8	15,4	23,6	25,3	25,2	24,6	22,6	19,5	17,6	15,2	12,2	

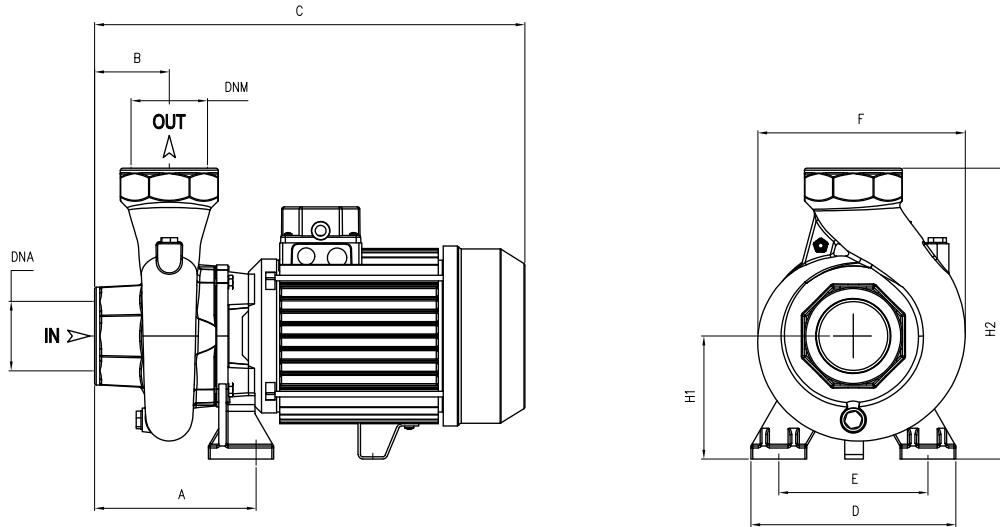



TYPE		DIMENSIONS (mm)													 Kg	
-1	-3	A	B	C	D	E	F	H1	H2	DNA	DNM	I	L	M	-1	-3
CS 75/2	CST 75/2	127	45	315	155	115	178	97	247	2" G	2" G	340	195	280	14,5	14
CS 100/2	CST 100/2	127	45	315	155	115	178	97	247			340	195	280	16	15
CS 120/2	CST 120/2	127	45	315	155	115	178	97	247			340	195	280	16,5	16
CSB 100/2	-	130	70	395	180	130	195	90	240	2" G	2" G	420	230	309	23	-
CSB 150/2	CSBT 150/2	130	70	395	180	130	195	90	240			420	230	309	23	23
CS 150/2	CST 150/2	150	53	400	180	140	218	115	285	2" G	2" G	420	230	309	27	27,5
CS 200/2	CST 200/2	150	53	400	180	140	218	115	285			420	230	309	26	27,5
CS 250/2	CST 250/2	150	53	400	180	140	218	115	285			420	230	309	27,5	28
CS 200/3	CST 200/3	176,5	80	485	184	130	225	112	292	3" G	3" G	520	235	320	33	28
CS 300/3	CST 300/3	176,5	80	485	184	130	225	112	292			520	235	320	33	30,5
-	CST 400/3	176,5	80	485	184	130	225	112	292	4" G	4" G	546	265	355	46,5	42,5
CS 450/4	CST 450/4	165	85	515	200	150	250	130	330			546	265	355	-	47
-	CST 550/4	165	85	515	200	150	250	130	330			675	390	300	-	56,5
-	CST 750/4	117	83	559	215	170	254	134	333			675	390	300	-	63
-	CST 1000/4	117	83	559	215	170	254	134	333							