

HI-168

HOME BOOSTER PUMPS



- Liquid temperature : 0~40°C / 32~104°F
- HP range : 1/4HP / 200W
- PH : 6~8
- Rated Speed : 2900 / 3450 rpm
- Protection class : IP55
- Maximum suction : 9M

Features

1. Copper impeller.
2. Silent gear pump
3. Self-priming capacity of up to 9 meters

Applications

1. Household pumping and pressurization applications
2. RO filtration system
3. Sprinkler system

Specification

Model No.	Output		Outlet		Startup pressure Kg/cm ²	Max Flow(LPM)	LPM Flow @ Head					Max Head(M)	Weight Kg
	HP	W	mm	inch			5M	10M	15M	20M	25M		
HI-168	1/4	200	25	1"	1.5	35	31	27	22	16	7	28	9

Dimension

Dimension										
Model	L	L1	L2	W	W1	W2	W3	H	H1	H2
	mm	mm	mm	mm	mm	mm	mm	mm	mm	mm
HI-168	239	174	69	188	130	90	156	307	178	86

Curve

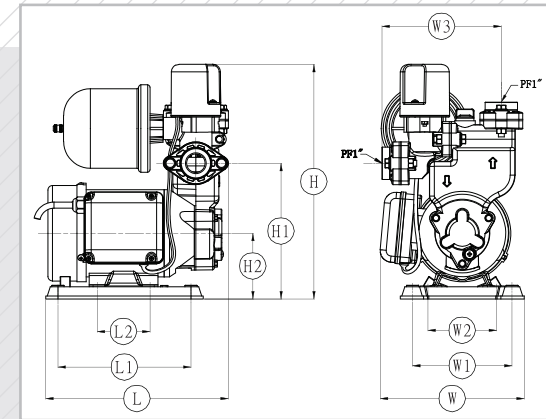
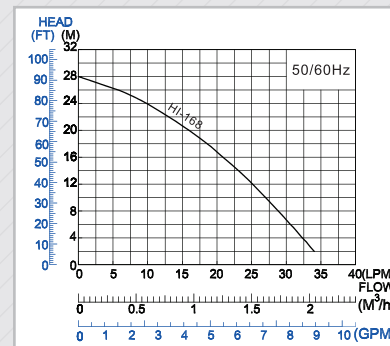

Standard Accessories

Model No.	Accessories
HI-168	Flange*2, Packing for strainer*1, Packing*1

