



Instruction Manual

SLIM ION BAR ASG-P Series



Read this instruction manual before using the product in order to achieve maximum performance.
Keep this instruction manual within your reach after reading so that it can be used at any time.

CONTENTS

1. Product Introduction		03Page
1.1 Features	1.2 Specification	
1.3 Dimensions	1.4. Performance	
1.5 Package contents	1.6 Part names	
1.7 Cautions and warranty		
2. Installation & Connection		08Page
2.1 Installation location	2.2 Purging and moving into CR	
2.3 Wiring diagram	2.4 Installing and connecting main body	
2.5 Connection with Daisy-Chain	2.6 Check list after installation	
3. Settings		15Page
3.1 How to set values	3.2 Explanation on Menu options	
4. Maintenance		17Page
4.1 Necessity of the maintenance	4.2 How to clean and replace an emitter	
APPENDIX		19Page
1. Trouble shooting		
2. Warranty		

Before installation, be sure to read carefully at least

1.7 Cautions

2. Installation & Connection parts

1.1 Features

Welcome to become a customer of DIT!

ASG-P Series is a slim bar ionizer designed to be easily installed in narrow space, while succeeding its predecessor's (MB-GW series) outstanding performance.

ASG-P Series is,

- More suitable for medium short distance static elimination.
For long distance static elimination, we recommend our ASG-A Series.
- Safe from fire by using own piezo ceramic for HVPS(High Voltage Power Supply).
- able to keep stable Ion Balance due to its patented **Auto-Balancing function**

1.2 Specifications

Series name	ASG - P	Air	Type	CDA, N2
Length	Min 350 ~ max 3000 mm (increasing by 50mm)		Pressure	0.05 ~ 0.5MPa(Usually under 0.3MPa)
Ion generating method	Corona discharge		Flow	2.0L/min(±10%) per 1 emitter (under 0.1MPa)
Voltage application method	Pulse AC		Air tube diameter	∅6 (outside)
Input Voltage	DC24V±10%	Material		Main body: ABS / Emitter pin: Tungsten
Input Current	MAX. 300mA	Display		Alarm LED(Green/Red), 3-Digit(Error and Status display)
Output Voltage	±4.7kV(±5%)	Controllable factors		Ion on/off, Address, Communication speed Password, Resetting, Tip cleaning period setting
Output Frequency	29kHz	Remote control range		Within 5M in lineal distance
Ion Balance	Under average ±30V	Ambient temperature		0℃ ~ +50℃(32~113°F)
Weight(g)	Min : 370g(ASG-P035), Max : 3200g(ASG-P300)	Relative humidity		35~85%RH(No dewing)
Power consumption	MAX. 24W			
Ozone generation	Under 0.05ppm			

※ Specification can be changed without notice for performance improvement

1. 3 Dimensions

<ASG - P050W>

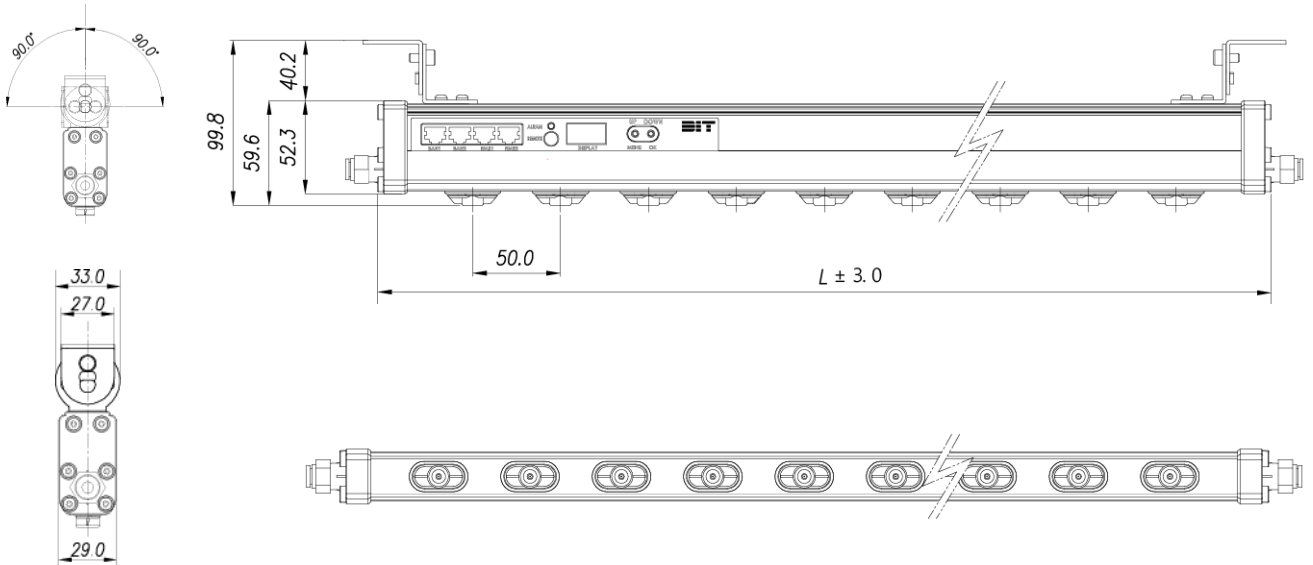

<Bracket>

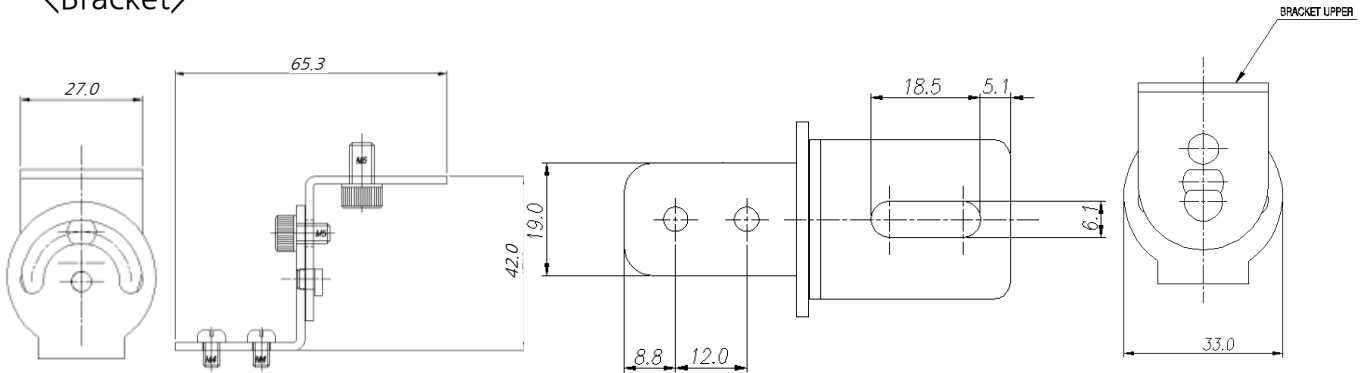

Model	Number of emitters(EA)	Length(mm)	Model	Number of emitters(EA)	Length(mm)
ASG-P035	6	346	ASG-P190	37	1896
ASG-P050	9	496	ASG-P210	41	2096
ASG-P090	15	896	ASG-P240	47	2396
ASG-P120	23	1196	ASG-P270	53	2696
ASG-P150	29	1496	ASG-P300	59	2996

1.4 Performance

※ Discharge time: the time necessary for static elimination

Relation between discharge time and distance (Distance: mm, discharge Time: sec) :

shows discharge time according to the distance measured in product's side and front perspective. (Used product: ASG-P060W)

Relation Between Depth Direction and Decay Time

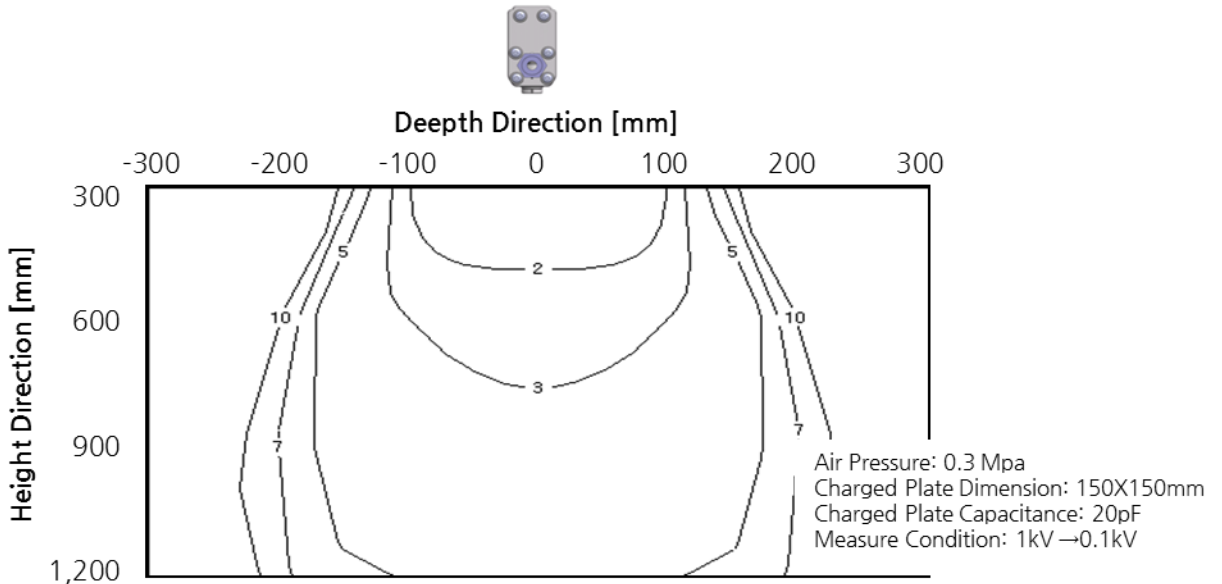

Relation Between Width Direction and Decay Time

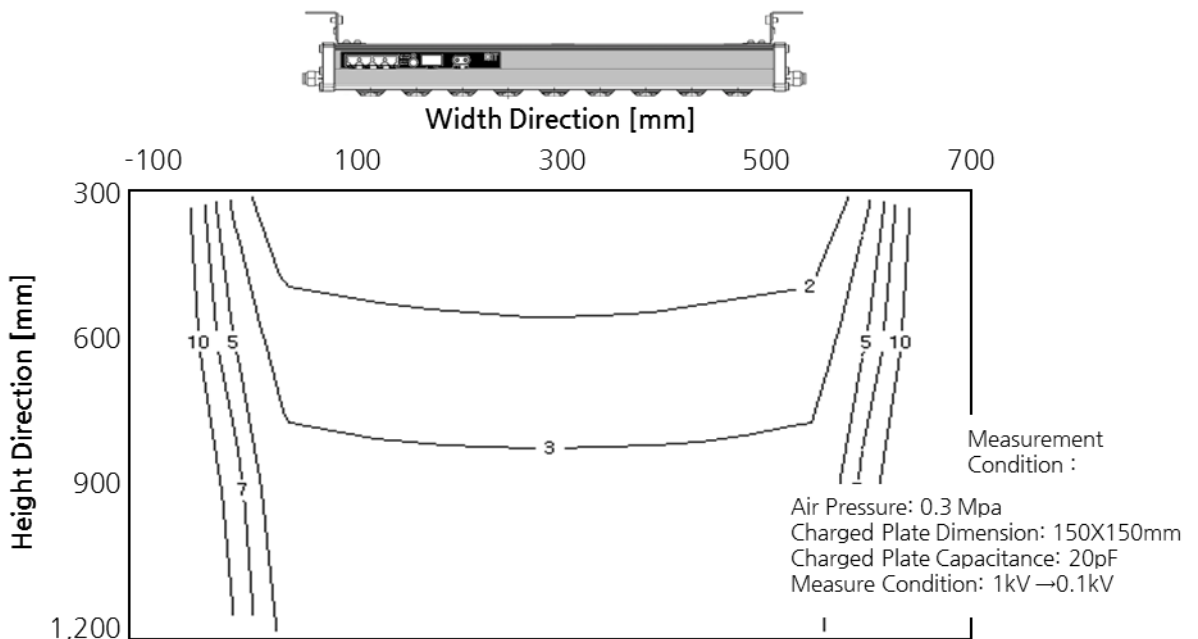

1.5 Package Contents

< Package >

① Main body(controller & power supply embedded)



② Support brackets and screws



※ Contact to the seller for customizing

③ Power cable A (RJ-45[8PIN])



※ Length: 3M

< Options >

① Ion emitter Kit
For replacement
(10ea/set)



② Additional cable A/B
For daisy-chain



③ Remote controller



④ Mid support brackets



1.6 Part Names

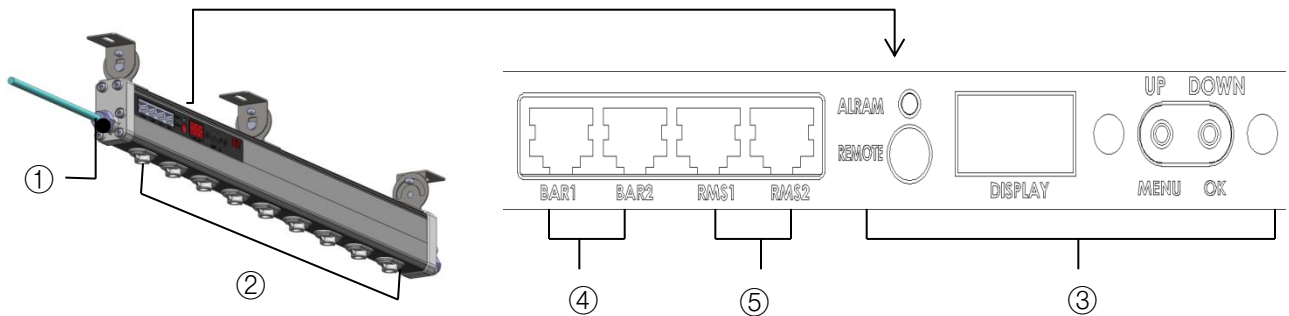

① Air feeding entrance

② Ion emitters

③ Control Panel

④ RJ-45 Power cable connector (Bar1, Bar2)

⑤ RJ-45 Communication cable connector (RMS1, RMS2)

1.7 Cautions

Please be well informed of the cautions below before installation.

- Safety

- . To avoid the risk of electric shock or product malfunction, keep fingers and metallic objects away from the unit during operation.
- . Make sure that there is adequate ventilation when using the Unit in an enclosed space because static elimination using Corona Discharge method generally generate a small quantity of ozone.
- . To avoid the risk of electric shock, be sure to turn the power off during the maintenance.
- . To avoid the risk of injury, do not touch the emitter pin directly with your hands.
- . Disconnect from power supply and remove all the air in the unit before installing or moving.
- . To avoid explosion, do not install the Unit in a place surrounded with volatile material or a lot of particles.

- Power supply

- . Use a DC power supply at voltage of 24V+-10%
- . Be sure to use a stabilized DC power supply.

- Installation

- . Don't use any other parts not enclosed in the package.
- . Do not install in regions affected by strong electric magnetic fields.
- . Keep appropriate distance between two units to avoid mutual interference (refer 8page)
- . Do not connect power code to communication port (RMS1, RMS2)
- . Be careful not to apply excessive force on air feeding entrance or side cover, especially when installing the Unit vertically.

- Air

- . Remove impurities like water or oil from the air in compressor by using filters or air dryers before use.
- . Install the unit after making sure that there is no foreign material in the air passage.

Non-observance of the above and **Warning!** in this manual may lead to injury or product malfunction. DIT doesn't take any responsibility for the damage if the Unit is used in a manner that differs from the specification in this manual or if the Unit is modified by yourself

2.1 Installation Location

- Provide enough space between the static elimination bar and surrounding walls as shown in the figures below.

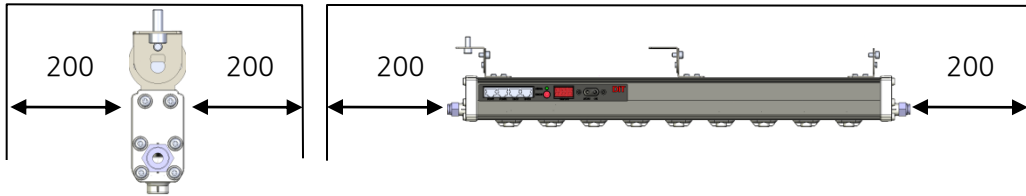

- If two SGA-A units are used, refer to the following illustration and separate the static elimination bars properly.

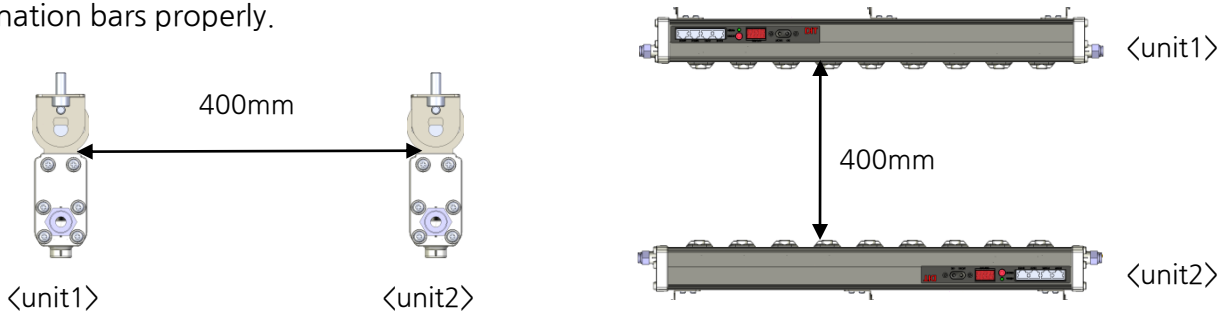

- Keep at least 20cm distance between the Unit and the static charged object.

2.2 Purging and moving into CR(Clean Room)

< Purging >

ASG-A series is packaged after purging in our clean room to remove dust. However, if needed, execute purging process according to the below.

- 1) Install the unit.
- 2) Feed the Unit CDA or N2 gas at about pressure of 3Bar(0.3MPa)
- 3) After purging for a period of time, check the particle level with a counter to make sure that it is suitable for Clean Class

< Moving the Unit into clean room >

















We recommend doing the below process before moving the Unit into a clean room.

- 1) Remove the wrapping paper outside the clean room.
- 2) Clean the outside of the plastic wrap with cleansing solution
- 3) Moving the Unit into clean room using a pass box
- 4) Remove the plastic wrap before installation

※ If you have your own process for Clean Class, you can apply it.

2.3 Wiring diagram



Usage	PIN No.	Color	Wiring	
Power & PLC cable	①	Black 	Power Supply Ground, Field Ground	For power supply
	②	Brown 	Power Supply Ground, Field Ground	
	③	Red 	+24 DC Power Supply	
	④	Orange 	+24 DC Power Supply	
	⑤	Yellow 	PLC Circuit +24 DC Power Supply	For PLC
	⑥	Green 	PLC Circuit Ion Alarm Signal	
	⑦	Blue 	PLC Circuit On/Off Signal	
	⑧	Violet 	PLC Circuit Ground	
Communication cable	①	Black 	Communication TX(+) Signal	
	②	Brown 	Communication TX(-) Signal	
	③	Red 	NOT CONNECT	
	④	Orange 	+24 DC Power Supply(Output : DC+24V)	
	⑤	Yellow 	NOT CONNECT	
	⑥	Green 	NOT CONNECT	
	⑦	Blue 	NOT CONNECT	
	⑧	Violet 	Power Supply Ground, Field Ground	

2.3 Wiring Diagram

〈ASG-A Series PLC Circuit Diagram〉

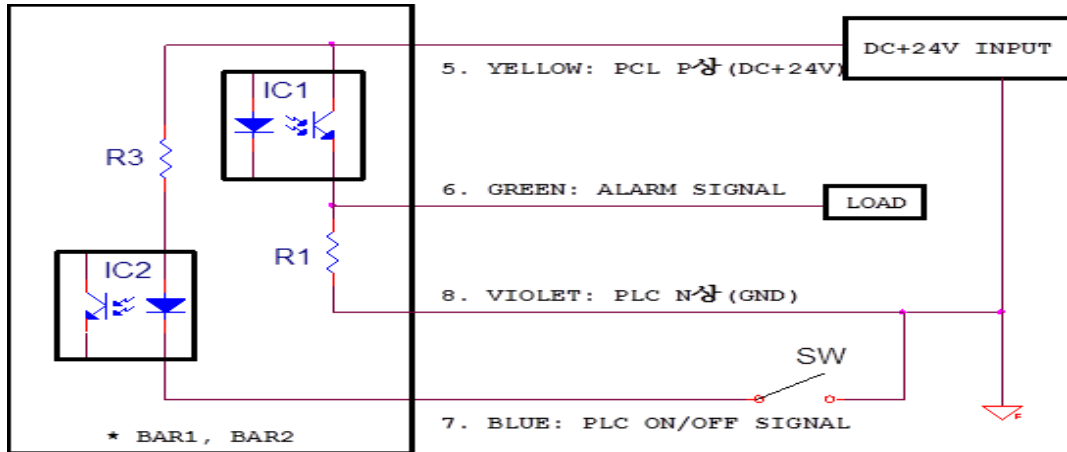

- Connection without PLC

- 1) Connect the black and brown cables to a power and field ground.
- 2) Connect the red and orange cables to DC 24V
- 3) To avoid short, cut the other 4 cables shortly and tapping them with deliberation

- Connection when using PLC

- 1) Connect the black, brown and violet cables to a power and field ground.
- 2) Connect the red, orange and yellow cables to DC 24V
- 3) Connect the blue cable to the ground, the same point of black, brown and violet cables, which makes PLC work. If you open it, PLC doesn't work
(Please refer to the ASG-A Series PLC Circuit Diagram below)
- 4) The green cable is for an alarm signal
 - Normal condition: 0V output
 - Abnormal condition: 24V(500mA) output
 - Setting Load: Set the output current under 100mA

- Connection when using an adaptor

- 1) Connect the black and brown lines to the adaptor (-)
Make sure that either one of the lines should be connected to an earthed part of the machine.
- 2) Connect the red and orange lines to the adopter (-)
- 3) If you are using PLC, connect corresponding lines to PLC; otherwise cut off the rest of the lines not in use.

2.4 Installing main body

< Installation order >

- ① Assemble the brackets firmly into a main body

Warning!

If you fix the Unit without using the brackets in package, be careful the weight not to be applied on the side cover, which can result in air leakage

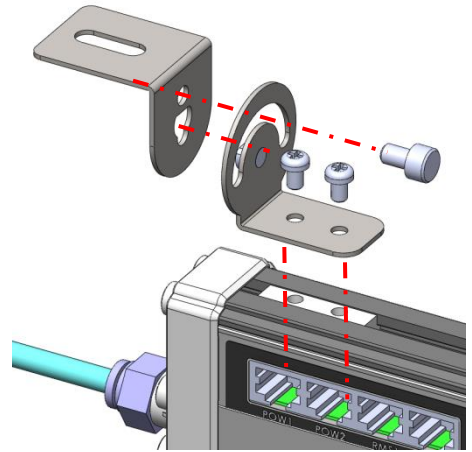

- ② Fix the main body with M5 screws

Warning!

Before fixing the main body, make sure that you complied all the precautions (p7) and location guide(p8)

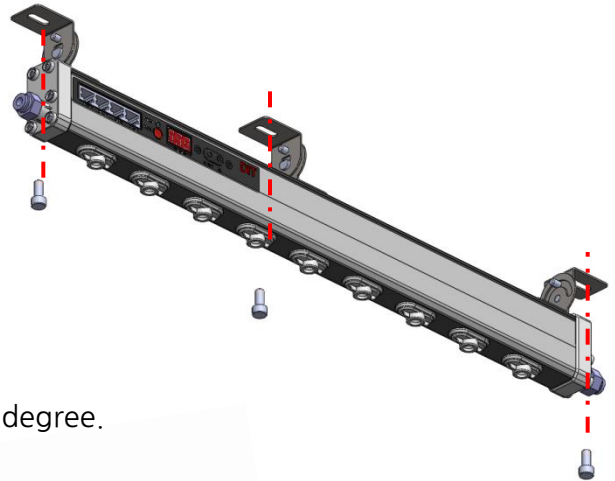

- ③ You can control main body angle up to 180 degree.

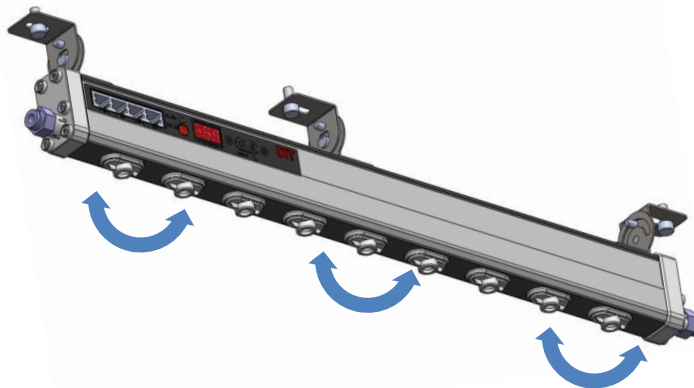

2.4 Installing main body

④ Connect power cable

Connect RJ-45 power cable (A or B types) to BAR1 or BAR2 by pushing the cable until you hear 'tic' sound.

Warning!

- . If the power cable is connected to RMS1 or RMS2, the device can be damaged.
- . For guaranteed performance, make sure that GND line of the power cable should be earthed.

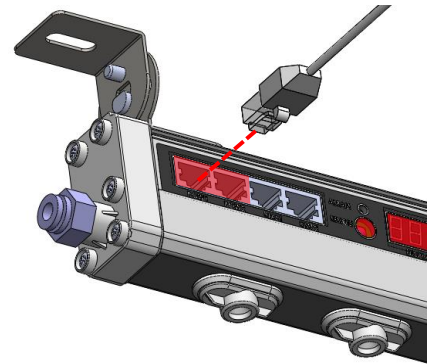

⑤ Connect communication cable (when using RMS)

Connect RJ-45 communication cable (A or B types) to RMS1 or RMS 2 (the connector part of RJ-45) by pushing the cable until you hear 'click' sound.

Warning!

Make sure that you understand the connection diagram and make connections accordingly.

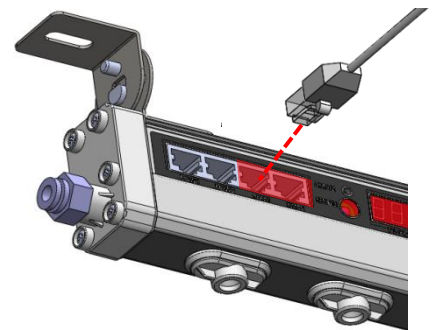

⑥ Feed the air

6 mm diameter tube is used in ASG-A. Connect tube by pushing it through air fitting until you hear 'click' sound.

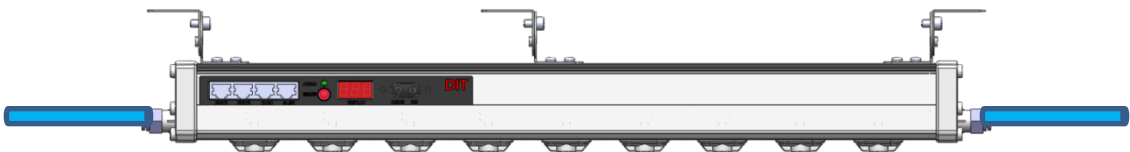

Warning!

- . Make sure that air pressure should be lower than 0.5 MPa.
- . Air pressure lower than 0.3 MPa is recommended.
- . Flow rate and cleanness of supplied air is crucial for performance and cleaning cycle of the device.

2.5 Connection with Daisy-Chain

< What is Daisy-Chain? >

- . Electric power: transfer electric power from one unit to another. Up to two electric power units can be serially connected.
- . Telecomm: information from each unit can be integrated and controlled by assigning different addresses to each unit.

< How to make Daisy-Chains? >

- . Electric Power: As demonstrated below, power is supplied to <unit 1> using RJ45-A type cable. Power can be supplied to <unit 2> from <unit 1> by connecting them using RJ45-B. Use BAR1 or BAR 2 connecting part on each unit.
- . Telecomm: As demonstrated below connect <unit 1> to PC using RJ45-A. Connect <unit 2> to <unit 1> using RJ45-B. Use RMS1 or RMS2 port on each unit.

Warning!

If you are using cables other than ones provided by us, please consult us or our agency.

If multiple units are connected, make sure that sufficient air and power are supplied.

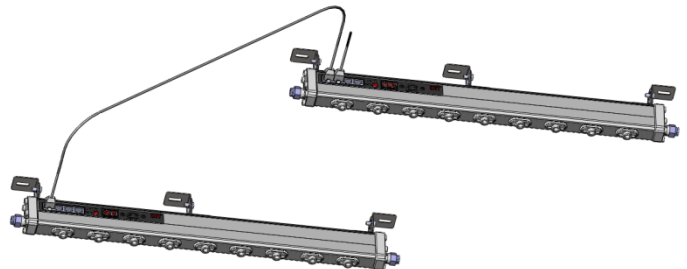







2. 6 Check list after installation

Recheck the below list before operating the Unit.

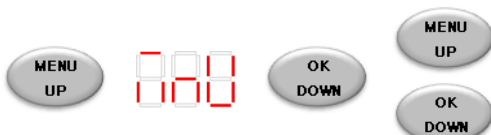
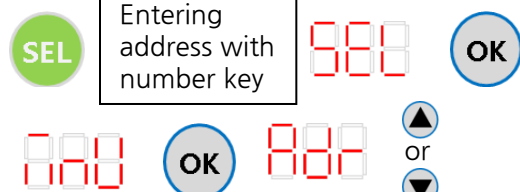
- (1) Make sure that power and air supply are properly connected. Check if proper amount of air flow and power are supplied to the unit. Excessive or deficient amount of air and power may cause damages to the device.
- (2) Check operation environment that may cause malfunction, failure or shorting the life of the device, such as strong magnetic or heat sources.
- (3) Check if there are any metallic objects in the vicinity of the device, (<5 cm), or within the operating distance. Metallic objects nearby hinder ion generation; metallic objects within the operating distance block ion moving toward targets for static control.
- (4) Check if emitter is installed correctly. Operation without the emitter may seriously damage the device or cause malfunction of the device.
- (5) Check if the device is loaded with excessive weight or subject to shock. Excessive load or shock to the device may cause serious damage such as malfunction or air leakage from broken/bent air duct.

Our ASG-P Series are ionization devices using Corona Discharge method. Ion emission and ion balance are subject to operation environment, please make yourself familiar to the device, instruction, and cautions before using the device.

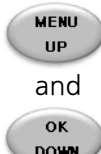
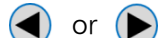
3. 1 How to set values

	When using key panel	When using remote controller
Entering Menu mode and finding an option	 <p>Press "Menu" key: "MnU" is displayed on the panel. Press OK to enter the main Menu.</p> <p>Use UP DOWN keys to find a specific menu option that you need</p>	 <p>Entering address with number key</p> <p>Entering right address display "SEL" on FND. Pressing "OK" display "MnU" on FND. Press OK one more time to enter the main Menu.</p> <p>Use "▲" or "▼" to find a specific menu option that you need</p>
Entering a specific menu option (Ex: Address setting)	 <p>2 Seconds</p> <p>Hold "OK" for 2 seconds when the panel displays "Adr". You can see the previous setting value on display.</p>	 <p>Hold "OK" for 2 seconds when the panel displays "Adr". You can see the previous setting value on display.</p>
Setting and saving a value	 <p>2 Seconds</p> <p>Use "UP", "DOWN" keys to change the value and press "OK" for 2 seconds to save the changed value.</p>	 <p>Use "▲" or "▼" to change the value and press "OK" for 2 seconds to save the changed value.</p>
Switching digits	 <p>Press "UP" and "DOWN" keys together and move to next digit. Check you have FND light blinking. Use "UP" and "DOWN" keys to make changes.</p>	 <p>Press "◀" or "▶" to move to next digit. Check you have FND blinking. Use "▲" or "▼" to make changes</p>
Returning to initial Menu mode	 <p>2 Seconds</p> <p>Press "MENU" for more than 2 seconds to return to initial Menu mode. Press "MENU" one more time to return to a standby mode.</p>	 <p>Press "ESC" to return to initial Menu mode. Press "ESC" one more time to return to a standby mode.</p>

3. 2 Explanation on menu options

Menu	Explanation	Notes
Adr	Setting Address	Assigning "A01" - "A63" is allowed (up to 63 units). If there are duplicated addresses, controlling the system with a remote controller may result in false operation by controlling a wrong unit.
Ion	Ion On/Off	When ion output is "oFF", alarm LED changes to red and. "Er1" is displayed on FND.
FrE:	Setting Frequency	Frequency output may range from 0.1 to 60.0. "0.1 ~ 1.0": adjustment possible by 0.1 (increase/decrease) "1.0 ~ 10.0": adjustment possible by 1.0 (increase/decrease) "10.0 ~ 60.0": adjustment possible by 5.0 (increase/decrease)
voL	Setting Output Voltage Level	Output may have four levels: L-1(5.0) , L-2(5.5), L-3(6.0) and L-4(6.5)
bAL	Setting Ion Balance	Ion balance may range from 3.50 to 65.0.
tIP	Setting Emitter Pin Cleaning Period	If "Yes" is chosen to start cleaning cycle, "Er3" is displayed, when the end of cleaning cycle is reached. Once the pins are cleaned, reset the cleaning cycle. Cleaning cycle can be increase by week (one week as a unit; up to five weeks); t01~t52
PAS	Setting Password	When the password is on, you need to enter the old password to enter the main "Menu" for a new password setup. Password can be a three digit number, any number between 000 and 999.
PLC	Setting HVPS, Fan alarm output	nc: Normal operation - Output transistor is on. no: Normal operation - Output transistor is off.
Int:	Restoring initial factory settings	Factory setup is as follows. Adr : "A01" / Ion : "on" / FrE : "30.0" / voL : "L-4" bAL : "50.0" / PAS : "oFF" / PLC : "nC" / tIP : "no"

4. 1 Necessity of maintenance

- Necessity of emitter pin cleaning and emitter replacement

In general, when static controllers are continuously in operation for a long period, dust and dirt are accumulated around the emitter pin, called "fuzzy-ball". Depending on operating environment, 'fuzzy-ball' grows to block normal operation and results in deterioration in performance of static controller.

An emitter pin (inside a emitter) is a sharp, pin-shaped object, made from tungsten. ASG-P series produces ions using Korona Discharge method . Thus, during an operation, high voltage is applied on its emitter pin, which rounds the sharp pin away as the time goes on. A rounded emitter pin cannot produce ion as well as the sharp one.

For these reasons, emitter and emitter pin should be cleaned and replaced periodically.

If not cleaned, and replaced properly, worn-out emitter pin with fuzzy-balls, may deteriorate the quality and performance of your production. Make sure that emitter (and emitter pin) should be cleaned and replaced on a regular basis.

- Recommended cleaning cycle under the circumstance below : **Every 3 months**

- . Temperature : 22 °C [a higher temperature may lengthen the cycle]
- . Humidity : 50% [a higher humidity may lengthen the cycle]
- . Clean Class : 10,000 Class [a lower Class index may lengthen the cycle]
- . Quality of Supplied Air : CDA [purer air may lengthen the cycle]

※ The conditions listed above are for general environment, Actual result may slightly vary depending on the user's working environment. Six months cleaning cycle is based on test conditions used by DIT. Please compare DIT's conditions and your working environment and adjust it and set up cleaning cycle accordingly.

4. 2 How to clean and replace emitters

- How to clean an emitter

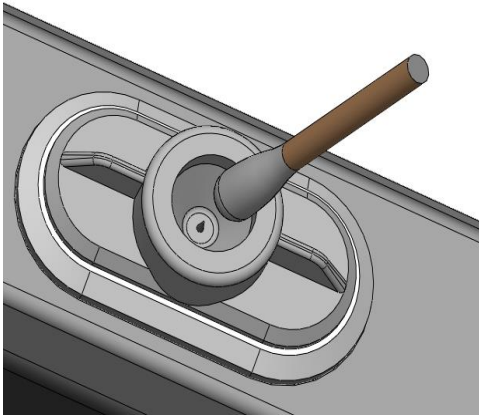

- ① Prepare soft brush or cotton swab with alcohol. (No acetone)
- ② Power off the device and stop the air input.
- ③ Wipe out the white 'Fuzzy ball' on the end of the emitter pin softly enough not to damage or scratch it.
- ④ Power on the device and feed the air
- ⑤ After 5 ~ 10 minutes, check the device performance with and measuring instrument.

- How to replace an emitter

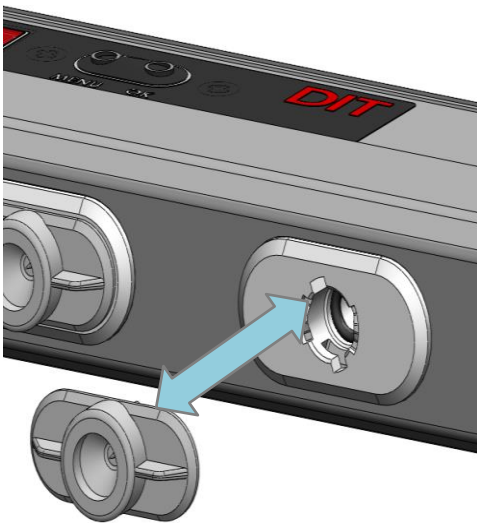

- ① Prepare a new emitter for replacement.
- ② Power off the device and stop the air input.
- ③ Rotate the emitter assembled in the unit counterclockwise
- ④ Pull the emitter to separate it from the unit
- ⑤ Insert a new emitter and rotate it clockwise to fix it firmly.
- ⑥ Power on the device and feed the air
- ⑦ After 5 ~ 10 minutes, check the device performance with and measuring instrument.

Trouble Shooting

Problem	Inspection
FND is not displayed	1) Check that the power cable is connected correctly (refer p.9)
Alarm LED is blinking in red	1) Enter the MENU using keys or a remote controller 2) Enter Ion menu and check that Ion is ON 3) When using PLC, check that PLC is ON
Ion balance is swing between + and -	1) Some swing is natural because of Auto Balancing function 2) Clean the emitter pin or replace the emitter
Smell of burning during operation	1) Turn off the power immediately. 2) Contact to the manufacturer
Remote controller doesn't work	1) Check and change the battery 2) Check the distance between the Unit and the remote controller (Max 2.5M) 3) Check the Unit address
Error message is displayed on FND	1) Er1 : Ion oFF error. Turn Ion on at Ion menu 2) Er2 : HVPS/Circuit error. Contact to sales agent or manufacturer. 3) Er3 : Emitter pin cleaning alarm message. Reset the pin cleaning period.

※ If you cannot solve the problem with the direction above or have other problems not described above, please call the manufacturer or leave a message on our website.

Warranty

We, Dong Il Technology Ltd. Manufactured this product under a strict quality control system and warrants it for 1 year of period from the shipment date.

However, we don't have any responsibility for

- 1) Any damage if the product is used in a way different from that is explained in this manual or remade by users arbitrarily.
- 2) Any damage led by improper usage. We recommend the installation circumstances in this manual, but that is just a recommendation and users are responsible for understanding the product's specification and judgment of suitability of usage.
- 3) Direct or indirect damage led by the product malfunction.