



# LED Display, Single-Phase, Slim, Power Controller

## ■ Specifications

Model	SPR1-1□□□□	SPR1-2□□□□	SPR1-3□□□□	SPR1-4□□□□
Control phase	Single-phase			
Rated load voltage (50/60Hz)	110VAC~	220VAC~	380VAC~	440VAC~
Power supply	100-240VAC~ 50/60Hz			
Min. load current	1A			
Permissible voltage range	90 to 110% of rated voltage			
Power consumption	<ul style="list-style-type: none"> <li>Rated load current 25A/35A/50A: max. 7VA</li> <li>Rated load current 70A/100A/150A: max. 12VA</li> </ul>			
Display method	3-digit 7-segment LED			
Indicator	<ul style="list-style-type: none"> <li>Operation indicator/Manual control indicator: green LED</li> <li>Alarm indicator/output indicator/unit (V, A) indicator: red LED</li> </ul>			
Control method	<ul style="list-style-type: none"> <li>Phase control: normal control mode, constant current/constant voltage/constant power feedback control mode</li> <li>Cycle control: fixed cycle control mode, variable cycle control mode</li> <li>ON/OFF control</li> </ul>			
Applied load	<ul style="list-style-type: none"> <li>Phase control, ON/OFF control: resistance load, inductive load</li> <li>Cycle control: resistance load</li> </ul>			
Control input	<ul style="list-style-type: none"> <li>Auto control: DC4-20mA, 1-5VDC<math>\overline{=}</math>, ON/OFF contact (no-voltage input), pulse voltage (5-12VDC<math>\overline{=}</math>)</li> <li>Manual control: outside adjuster (10k<math>\Omega</math>), inside adjuster (output limit)</li> </ul>			
Digital input (DI)	RUN/STOP switching, AUTO/MAN switching, RESET			
Output	Alarm	250VAC~ 3A, 30VDC $\overline{=}$ 3A, 1 $\Omega$ resistive load		
	Communication	RS485 communication output (Modbus RTU method), max. connection: 31 units		
Output range	<ul style="list-style-type: none"> <li>Phase control: 0 to 98%</li> <li>Cycle control: 0 to 100%</li> <li>ON/OFF control: 0%, 100%</li> </ul>			
Output accuracy	<ul style="list-style-type: none"> <li>Normal control: within <math>\pm 10\%</math> F.S. of rated load voltage</li> <li>Constant current feedback control: within <math>\pm 3\%</math> F.S. of rated load current</li> <li>Constant voltage feedback control: within <math>\pm 3\%</math> F.S. of rated load voltage</li> <li>Constant power feedback control: within <math>\pm 3\%</math> F.S. of rated load power</li> </ul>			
Set method	By front keys, by communication			
Functions		Output limit (OUT ADJ), AUTO/MAN selection, control method selection, RESET, SOFT START, SOFT UP/DOWN, output high/low limit, input correction, input slope correction, monitoring (control input, load voltage/current/power/resistance, power supply frequency, heatsink temperature)		
	Alarm	Overcurrent alarm, overvoltage alarm, fuse break alarm, SCR error alarm, heater break alarm, heatsink overheat alarm		
Cooling method	<ul style="list-style-type: none"> <li>Rated load current 25A/35A/50A: natural cooling</li> <li>Rated load current 70A/100A/150A: forced air cooling (with the cooling fan)</li> </ul>			
Insulation resistance	Over 200M $\Omega$ (at 500VDC megger)			
Dielectric strength	2,000VAC 50/60Hz for 1 min (between input terminals and power terminals)			
Output leakage current	Max. 10mA <sub>rms</sub>			
Noise immunity	$\pm 2$ kV the square wave noise (pulse width: 1 $\mu$ s) by the noise simulator			
Memory retention	Approx. 10 years (when using non-volatile semiconductor memory type)			
Vibration	Mechanical	0.75mm amplitude at frequency of 5 to 55Hz in each X, Y, Z direction for 2 hours		
	Malfunction	0.5mm amplitude at frequency of 5 to 55Hz in each X, Y, Z direction for 10 min		
Environment	Ambient temp.	-10 to 55°C, storage: -20 to 80°C		
	Ambient humi.	35 to 85%RH, storage: 35 to 85%RH		
Accessory	11-pin connector			
Approval	CE			
Weight <sup>※1</sup>	<ul style="list-style-type: none"> <li>Rated load current 25A/35A/50A: approx. 1.6kg (approx. 1.3kg)</li> <li>Rated load current 70A: approx. 1.65kg (approx. 1.35kg)</li> <li>Rated load current 100A/150A: approx. 3.2kg (approx. 2.8kg)</li> </ul>			

※1: The weight includes packaging. The weight in parenthesis is for unit only.

※Environment resistance is rated at no freezing or condensation.

(A) Photoelectric Sensors

(B) Fiber Optic Sensors

(C) Door/Area Sensors

(D) Proximity Sensors

(E) Pressure Sensors

(F) Rotary Encoders

(G) Connectors/ Connector Cables/ Sensor Distribution Boxes/ Sockets

(H) Temperature Controllers

(I) SSRs / Power Controllers

(J) Counters

(K) Timers

(L) Panel Meters

(M) Tacho / Speed / Pulse Meters

(N) Display Units

(O) Sensor Controllers

(P) Switching Mode Power Supplies

(Q) Stepper Motors & Drivers & Controllers

(R) Graphic/ Logic Panels

(S) Field Network Devices

(T) Software

# SPR1 Series

## Unit Description

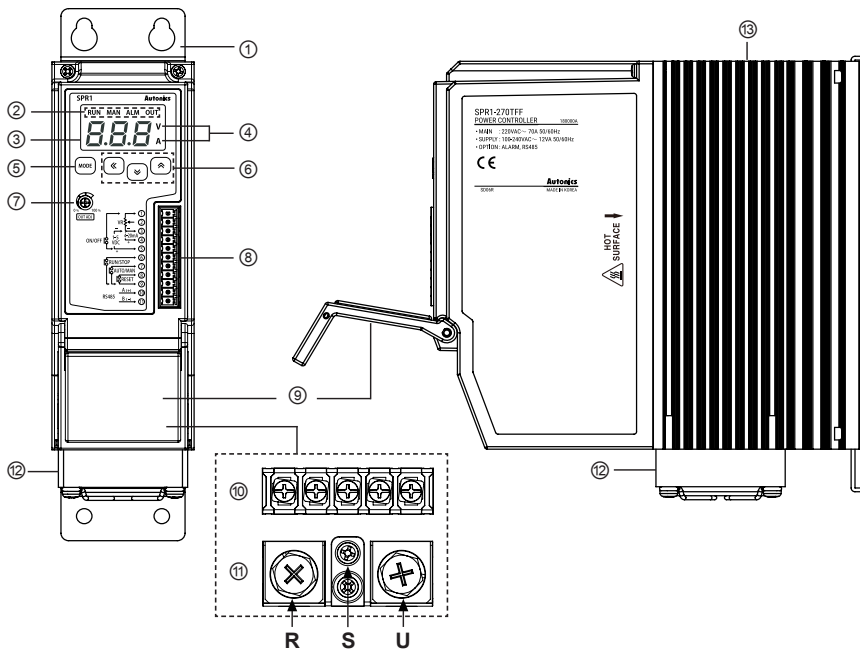

- ① Bracket
- ② Indicator

Indicator	Color	Function
RUN	Green LED	Turns on in the RUN mode.
MAN	Green LED	Turns on when adjusting load output in the manual control mode.
ALM	Red LED	Flashes in alarming status.
OUT	Red LED	Turns on when load control outputs.

- ③ Display part: Displays settings of the front display [ d1 5 ] parameter in RUN mode, and displays parameter and setting value in setting mode.
- ④ Unit indicator (☀: Light ON/●: Light OFF)

Indicator	Display
V	A
●	●
☀	●
●	☀
☀	☀

- ⑤ [MENU] key: Enters parameter group, returns to RUN mode, moves parameters, and saves the setting value.
- ⑥ Setting value adjustment key: Enters SV setting mode and move digits.
- ⑦ Output limit adjuster (OUT ADJ): Limits output from 0 to 100%.
- ⑧ 11-pin connector terminal
- ⑨ Terminal cover
- ⑩ Alarm output and power input terminals
- ⑪ R, S, U load output terminals
- ⑫ Cooling fan: For models with the rated load current of 70A/100A/150A, a cooling fan is attached.
- ⑬ Heatsink

## Wire Specification by Load Current

Rated load current	Wire specification		
	Alarm output/ power input	Load output	
25A/35A/50A/70A	AWG 18 to 14	S	R, U
100A/150A		AWG 18 to 14	AWG 13 to 4 AWG 4 to 2/0

# LED Display, Single-Phase, Slim, Power Controller

## ■ Dimensions

### ◎ Rated load current 25A/35A/50A

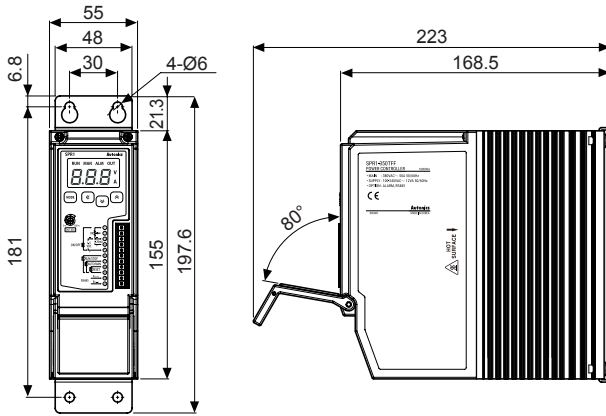

### ◎ Rated load current 70A

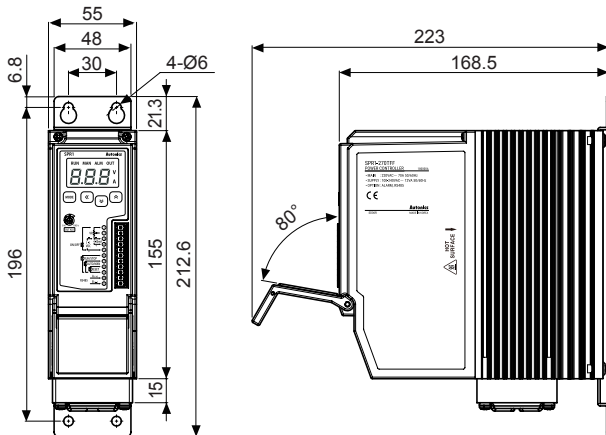

### ◎ Rated load current 100A/150A

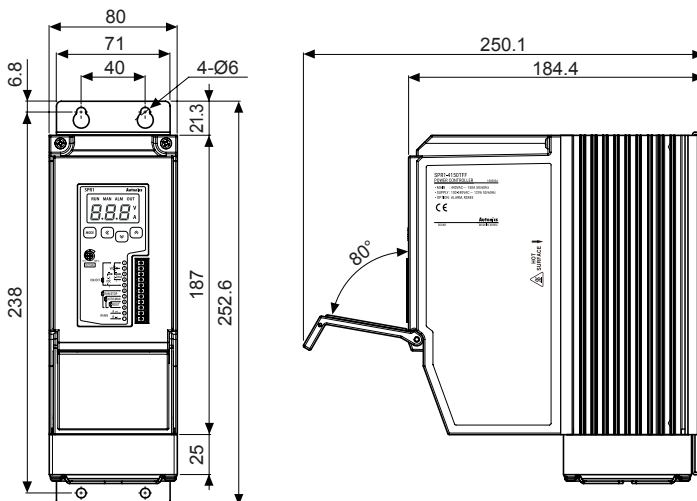

(unit: mm)

### ◎ Spacing

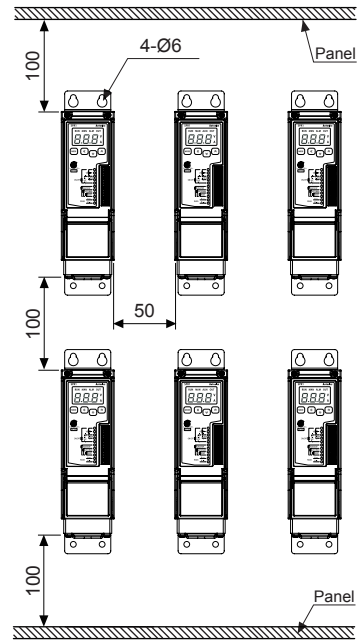

※When installing multiple power controllers, please keep space at least 50mm in horizontal and 100mm in vertical between power controllers for heat radiation.



### High Temperature Caution

While supplying power to the load or right after turning off the power of the load, do not touch the body and heatsink. Failure to follow this instruction may result in a burn due to the high temperature.

(A)	Photoelectric Sensors
(B)	Fiber Optic Sensors
(C)	Door/Area Sensors
(D)	Proximity Sensors
(E)	Pressure Sensors
(F)	Rotary Encoders
(G)	Connectors/ Connector Cables/ Sensor Distribution Boxes/Sockets
(H)	Temperature Controllers
(I)	SSRs / Power Controllers
(J)	Counters
(K)	Timers
(L)	Panel Meters
(M)	Tacho / Speed / Pulse Meters
(N)	Display Units
(O)	Sensor Controllers
(P)	Switching Mode Power Supplies
(Q)	Stepper Motors & Drivers & Controllers
(R)	Graphic/ Logic Panels
(S)	Field Network Devices
(T)	Software

# SPR1 Series

## ■ Connections

### ◎ Control input/Comm. output

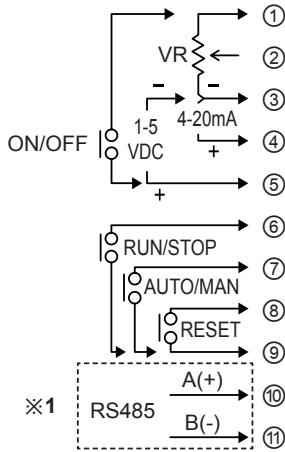

### ◎ Alarm output/power input

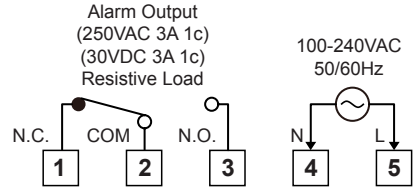

### ◎ Load output

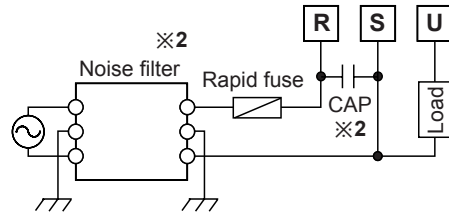

※1: This is only for models with RS485 communication output (SPR1-□□□□□□).

※2: When connecting noise filter and capacitor, it is appropriate for EMC.

CAP : Rated load voltage 110VAC-220VAC → 1uF/250VAC

: Rated load voltage 380VAC-440VAC → 0.47uF/500VAC

※Tighten the terminal screw with the below tightening torque.

Rated load current	Specification	Alarm output/ power input	Load output	
			S	R, U
25A, 35A, 50A, 70A	Screw	M3	M3	M6
	Tightening torque	0.5N·m	0.5N·m	5.5 to 6.0N·m
100A, 150A	Screw	M3	M3	M8
	Tightening torque	0.5N·m	0.5N·m	6.5 to 7.0N·m

※Use crimp terminals or terminals of size specified below.

(unit: mm)

Terminal type	Terminal number	a	b	c
Input (11-pin)	1 to 11	6 to 7	Max. 1.5	Max. 3.5
Terminal type		a	b	
Alarm output/power input		Min. 3.0	Max. 6.0	
Load output	S	Min. 3.0	Max. 8.0	
	R, U	Rated load current 25A/35A/50A/70A	Min. 6.0	Max. 16.0
		Rated load current 100A/150A	Min. 8.0	Max. 26.0

# LED Display, Single-Phase, Slim, Power Controller

## Derating Curve

Rated load current 25A

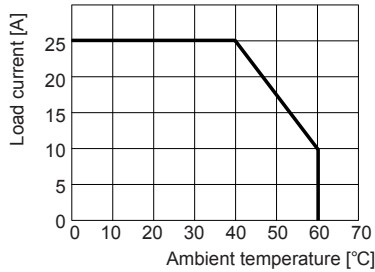

Rated load current 35A

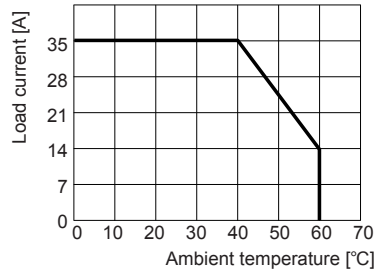

Rated load current 50A

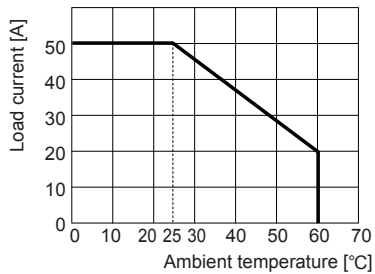

Rated load current 70A

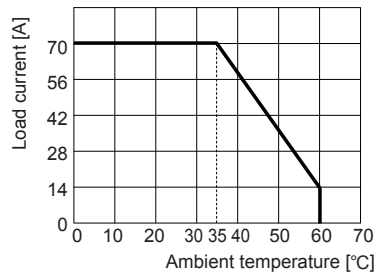

Rated load current 100A

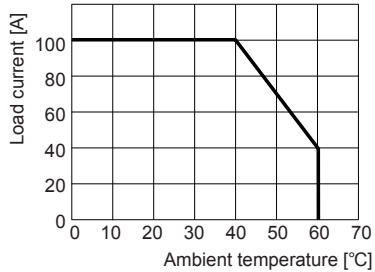

Rated load current 150A

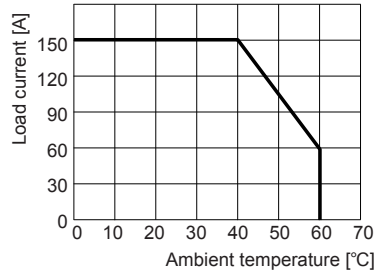

(A)	Photoelectric Sensors
(B)	Fiber Optic Sensors
(C)	Door/Area Sensors
(D)	Proximity Sensors
(E)	Pressure Sensors
(F)	Rotary Encoders
(G)	Connectors/ Connector Cables/ Sensor Distribution Boxes/Sockets
(H)	Temperature Controllers
(I)	SSRs / Power Controllers
(J)	Counters
(K)	Timers
(L)	Panel Meters
(M)	Tacho / Speed / Pulse Meters
(N)	Display Units
(O)	Sensor Controllers
(P)	Switching Mode Power Supplies
(Q)	Stepper Motors & Drivers & Controllers
(R)	Graphic/ Logic Panels
(S)	Field Network Devices
(T)	Software

# SPR1 Series

## ■ Parameter Group

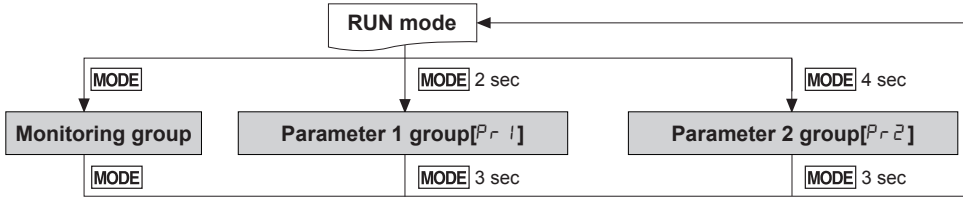

※ If there is no key input for 30 sec while setting SV or the parameters, the new settings are ignored, and the unit will return to RUN mode with previous settings.

※ Hold the **MODE** key for 3 sec while in setting mode to return to RUN mode.

## ◎ Monitoring group

※1: **S**: Press any key among **◀**, **▶**, **↵**.

※2: Press the **MODE** key once after changing the setting value, to save the setting value and move to the next parameter

※ Hold the **MODE** key for 3 sec to save the setting value and return to RUN mode after changing the setting value.

※  : Dotted parameters may not appear by model type or other parameter settings.

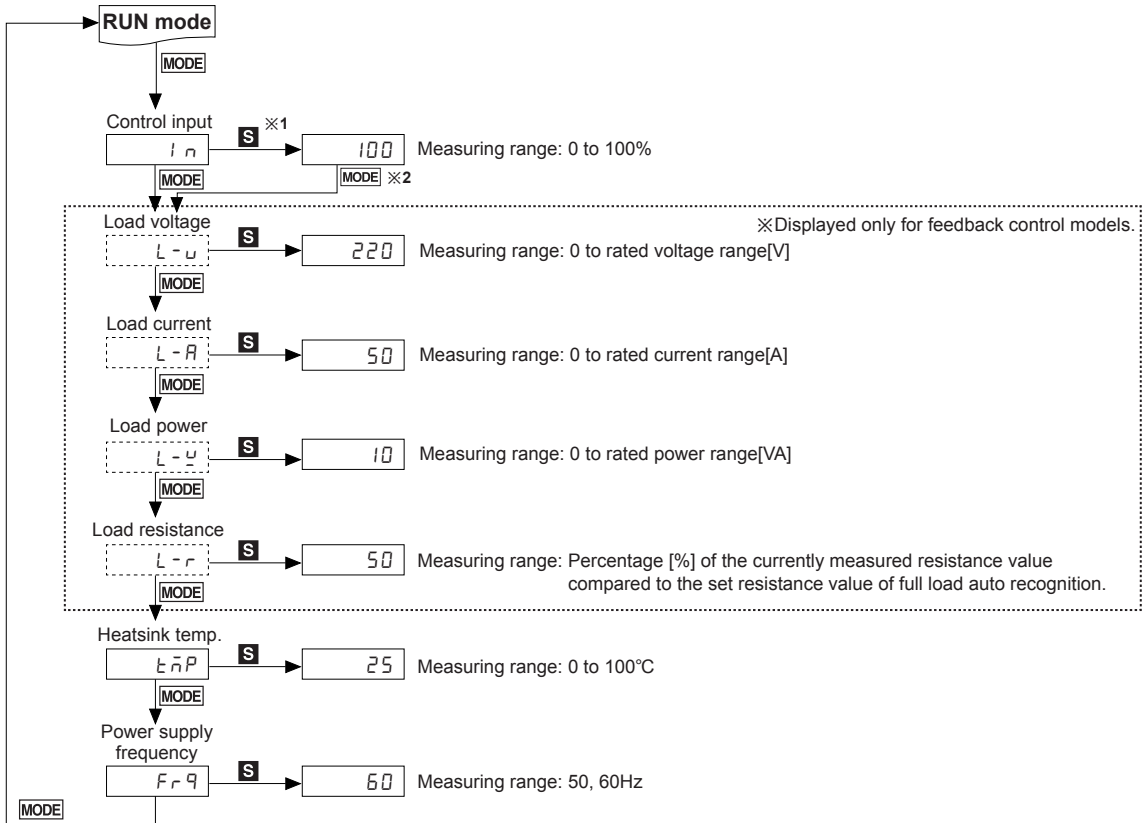

# LED Display, Single-Phase, Slim, Power Controller

## Parameter 1 group

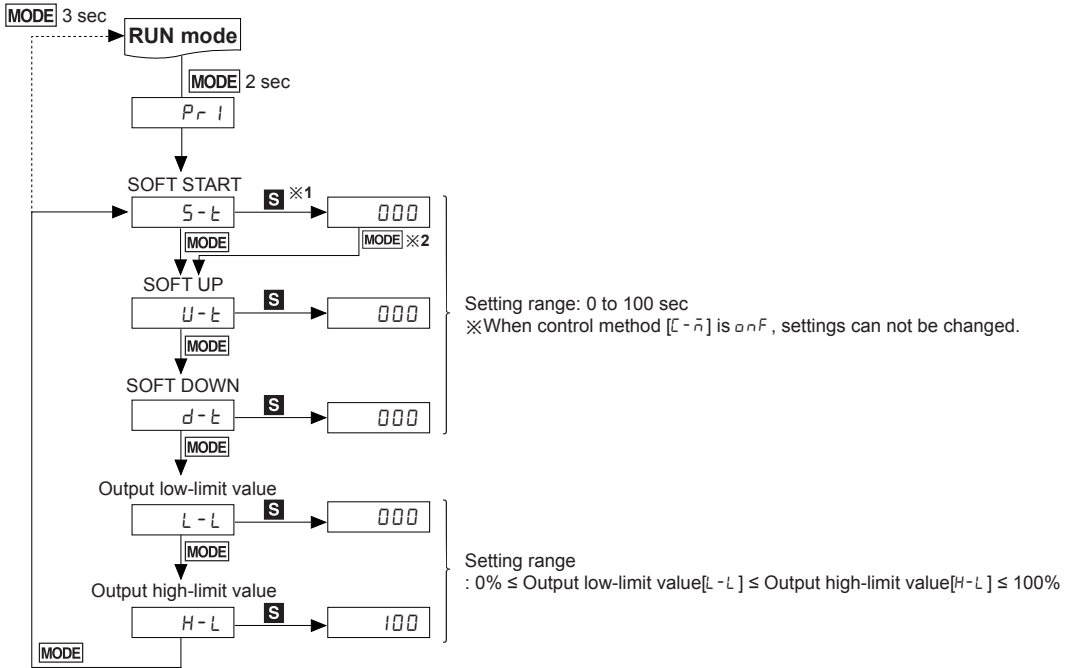

## Parameter 2 group

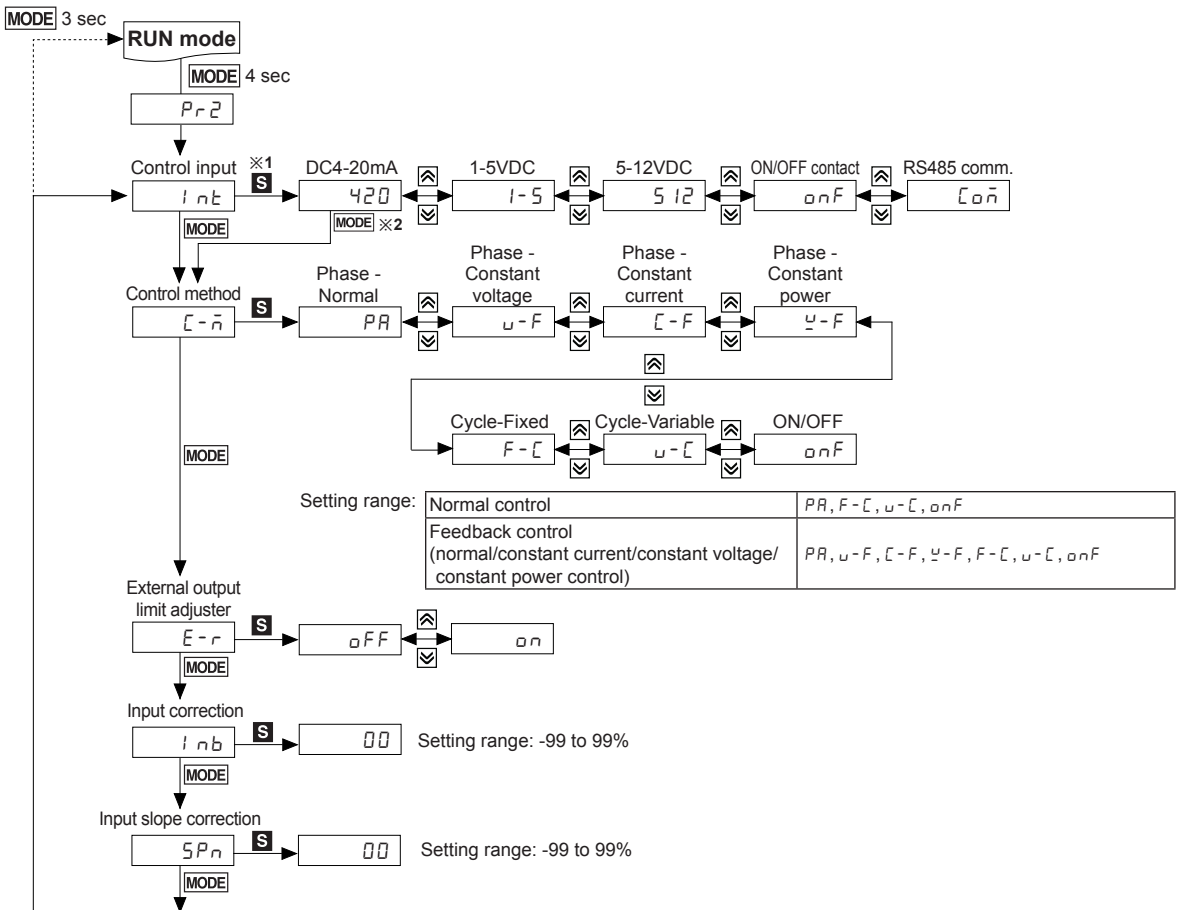

- (A) Photoelectric Sensors
- (B) Fiber Optic Sensors
- (C) Door/Area Sensors
- (D) Proximity Sensors
- (E) Pressure Sensors
- (F) Rotary Encoders
- (G) Connectors/ Connector Cables/ Sensor Distribution Boxes/Sockets
- (H) Temperature Controllers
- (I) SSRs / Power Controllers
- (J) Counters
- (K) Timers
- (L) Panel Meters
- (M) Tacho / Speed / Pulse Meters
- (N) Display Units
- (O) Sensor Controllers
- (P) Switching Mode Power Supplies
- (Q) Stepper Motors & Drivers & Controllers
- (R) Graphic/ Logic Panels
- (S) Field Network Devices
- (T) Software



# SPR1 Series

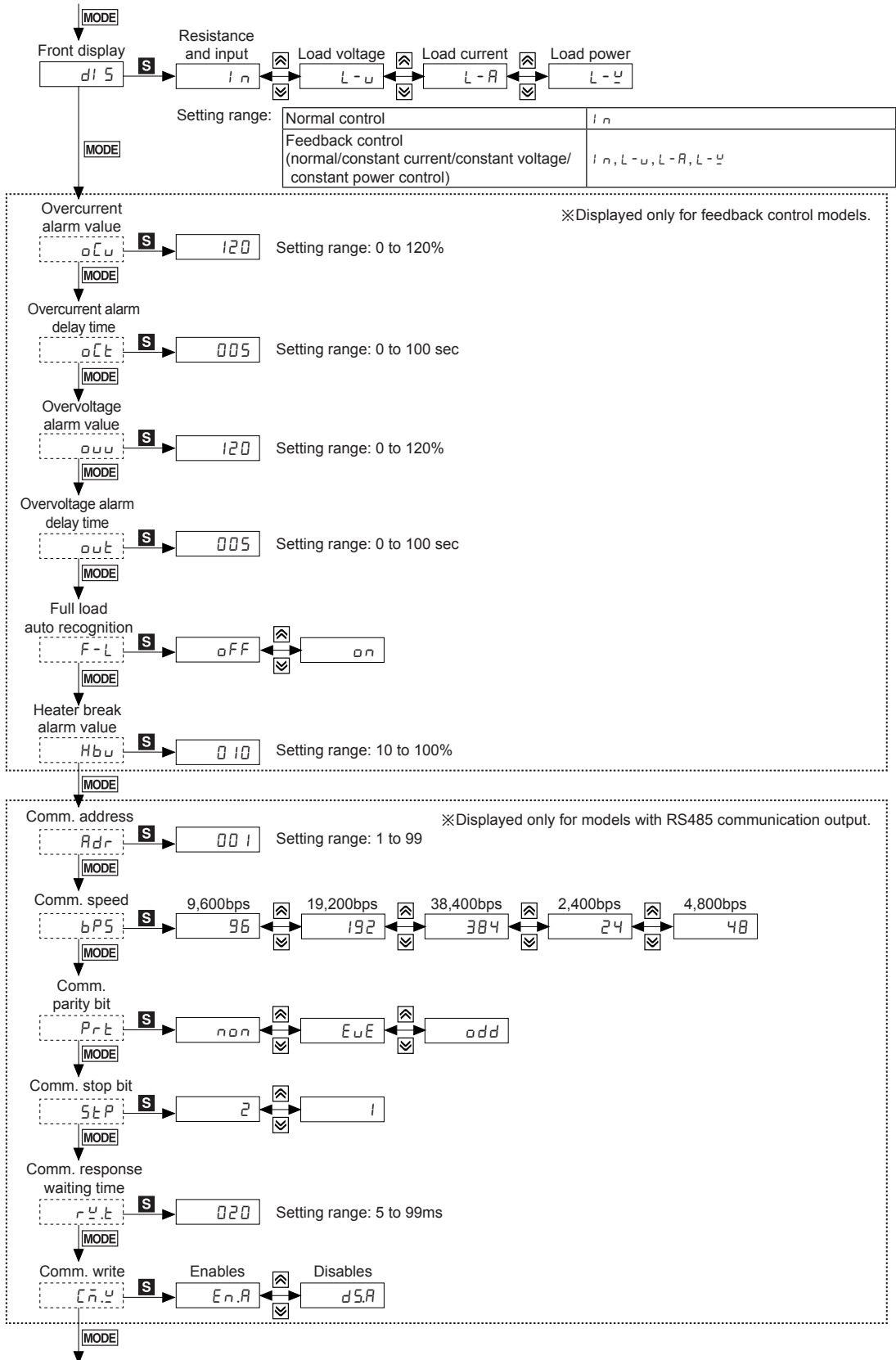

# LED Display, Single-Phase, Slim, Power Controller

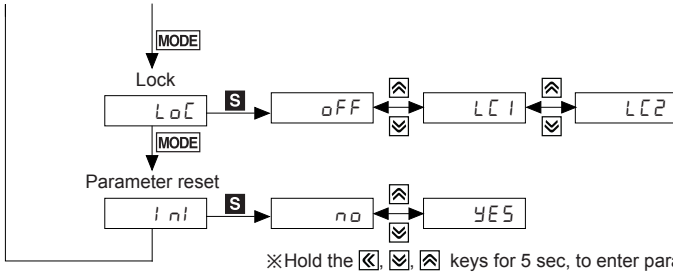

Setting range:

	Pr-1	Pr-2
oFF	●	●
Lc1	◐	●
Lc2	●	◐

●: Available to check/set

◐: Available to check/Unavailable to set

## ■ Control Method

### ◎ Phase control

#### ● Normal control mode

It is general output method to divide control angle proportionally according to control input signal and to output it.

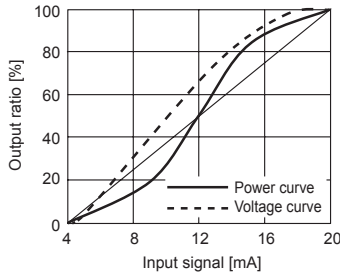

#### ● Constant current feedback control mode

If temperature coefficient of load (platinum, molybdenum, tungsten, etc) changes 6 to 12 times based on room temperature, it outputs constant current which is proportion to control input not to change output voltage for power supply variation, load resistance variation.

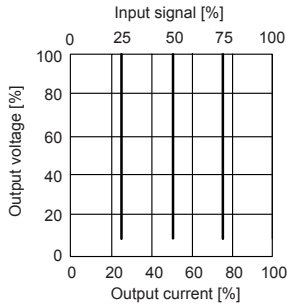

#### ● Constant voltage feedback control mode

At low temperature coefficient load(iron, chrome, nichrome, etc) of electrical resistance, it outputs constant output which is proportion to control input not to change output voltage for power supply variation, load resistance variation.

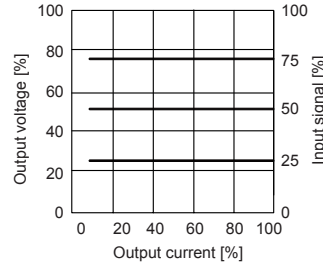

#### ● Constant power feedback control mode

It is proper control method for a heater which resistance value variation by silicon carbide (SiC) heating is big. It outputs constant power which is proportion to control input even though load variation and power supply variation.

Output characteristics is proper 50% of the curve which connects the point (A) [output voltage 100% × output current 50%] and the point (B) [output voltage 50% × output current 100%]. The current output capacity of this unit should be over two times of load capacity.

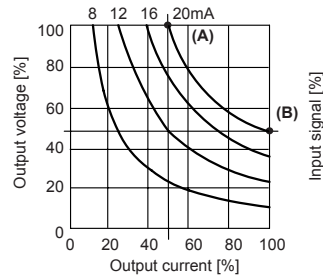

### ◎ Cycle control

#### ● Fixed cycle control mode

During fixed cycle (60 cycles) of load power, it repeats ON/OFF cycle as constant ratio according to control input signal and controls the power supplies on the load.

E.g.) When controlling output as 40%

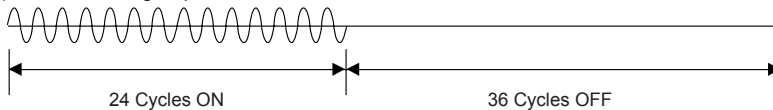

E.g.) When controlling output as 90%

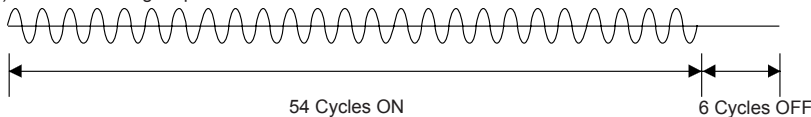

- (A) Photoelectric Sensors
- (B) Fiber Optic Sensors
- (C) Door/Area Sensors
- (D) Proximity Sensors
- (E) Pressure Sensors
- (F) Rotary Encoders
- (G) Connectors/ Connector Cables/ Sensor Distribution Boxes/Sockets
- (H) Temperature Controllers
- (I) SSRs / Power Controllers
- (J) Counters
- (K) Timers
- (L) Panel Meters
- (M) Tacho / Speed / Pulse Meters
- (N) Display Units
- (O) Sensor Controllers
- (P) Switching Mode Power Supplies
- (Q) Stepper Motors & Drivers & Controllers
- (R) Graphic/ Logic Panels
- (S) Field Network Devices
- (T) Software

# SPR1 Series

## • Variable cycle control mode

Variable cycle control controls required power using min. cycles of load power according to control input signal and optimize temperature changes of the subject.

E.g.) When controlling output as 30%

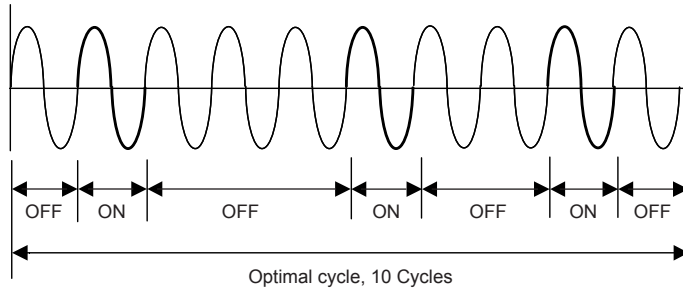

## ◎ ON/OFF control

This is control method that output is 100% at control input ON (approx. 18mA, min. 4.5VDC), and 0% at control input OFF (approx. 18mA, max. 4.5VDC).

※When using ON/OFF control method, output limit, SOFT START, SOFT UP/DOWN, input correction, and input slope correction functions are not settable.

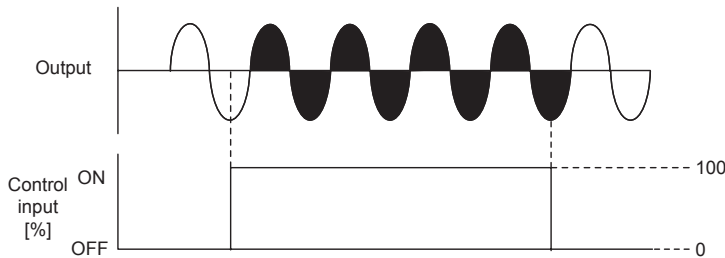

## ■ Functions

### ◎ Output limit (OUT ADJ)

This function will be  $[\text{Control input (\%)} \times \text{OUT ADJ (\%)} = \text{Output}]$  and it controls the power supplied into the load. Although control input is 100% (5V or 20mA), the output is the 50% which is proportioned with OUT ADJ.

※This function can not be used for ON/OFF control method.

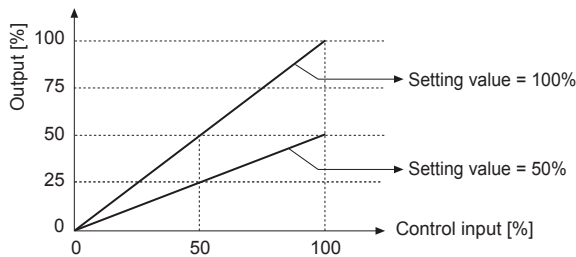

### ◎ SOFT START [S - t]

When the power is supplied, this function is able to protect the load when it controls load (molybdenum, white gold, infrared lamp) with inrush current or the width of rising temperature in big (SV is big). SOFT START set time (T) is the required time that output reaches to 100%, and it is differentiated by OUT ADJ set value.

※This function can not be used for ON/OFF control method.

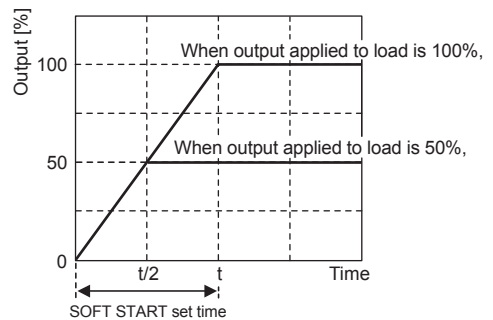

### ◎ Output high limit/low limit value [H - L / L - L]

This function is to limit output range to protect load.

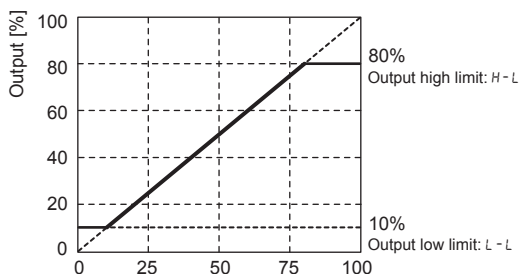

# LED Display, Single-Phase, Slim, Power Controller

## ◎ SOFT UP/DOWN [U-t / d-t]

Unlike SOFT START which operates only once at supplying power, this function protects load from the inrush current in the RUN mode. When reached to the target output value, operation stops.  
 ※ This function can not be used for ON/OFF control method.

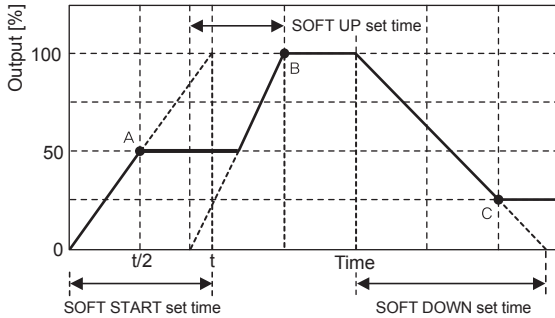

A: SOFT START function finished.  
 B: SOFT UP function finished.  
 C: SOFT DOWN function finished.

## ◎ Input correction [i nb]

It compensates the offset between actual input value and measured input value.

E.g.) When the input monitoring value is 5% at 4mA in DC4-20mA control input, setting *i nb* to -5 calibrates the input monitoring value to 0%.

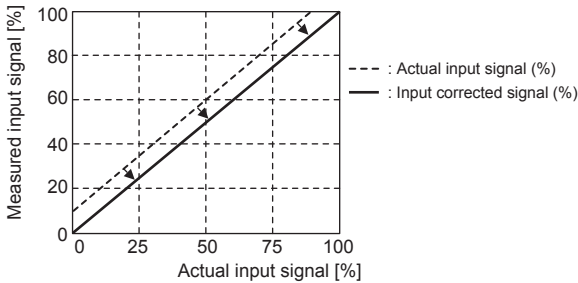

## ◎ Input slope correction [5Pn]

It compensates the gain of the measured 100% input for actual 100% input value.

$$\text{Calibrated monitoring value} = \text{Monitoring value} + \frac{\text{Monitoring value}}{100 - 5P_n} \times 5P_n$$

E.g.) When the input monitoring value is 99% at 4mA in DC4-20mA control input, setting *5Pn* to 1 calibrates the input monitoring value to 100%.

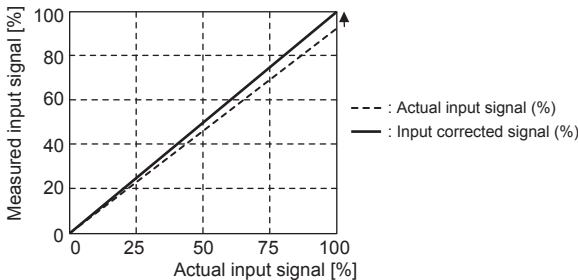

## ◎ RUN/STOP switching

RUN/STOP status of the power controller can be switched with the external RUN/STOP contact. In the RUN mode, the operation indicator on the front turns on.



## ◎ AUTO/MANUAL selection

Operation mode (auto control/manual control) of the power controller can be selected with the external AUTO/MAN contact. In the manual control mode, the manual control indicator on the front turns on.



## ◎ RESET

In the event of system anomalies and alarms, RESET input restarts the power controller. (Parameters are not initialized.) Or, hold the   keys for 2 sec, to operates RESET.



## ◎ Alarm

Type	Error	Operation	Clear alarm	Display priority
SCR error alarm <sup>*1</sup>	5Cr	Output stops. (SCR OFF)	- Re-supply the power. - RESET - Switch to STOP mode	1
Overcurrent alarm <sup>*1</sup>	o - t			2
Fuse break alarm	FU5			3
Heatsink overheat alarm	t E n			4
Overvoltage alarm <sup>*1</sup>	o - u			5
Heater break alarm <sup>*1</sup>	H - b	Continues operation	Automatically cleared when returning within the setting range	6

※1: This is only for feedback control models.

※ For models with alarm output, the error message and alarm indicator flash at the same time, and alarm output turns on.

※ When multiple alarms occur at the same time, the highest priority error message will be displayed based on priority.

### 1) SCR error alarm

Even though output is 0%, if the current of 10% or more of the rated load current flows for over 3 sec continuously, SCR error alarm occurs and output stops.

### 2) Overcurrent alarm [o t u t]

This function protects the load from overcurrent.

If the current flows over the overcurrent alarm setting value and setting delay time, overcurrent alarm occurs and output stops.

### 3) Heatsink overheat alarm

When the temperature of a heatsink is over 85°C, heatsink overheat alarm occurs and output stops.

### 4) Overvoltage alarm [o u u t]

This function protects the load from overvoltage.

If the current flows over the overvoltage alarm setting value and setting delay time, overvoltage alarm occurs and output stops.

### 5) Heater break alarm [H b u]

Comparing the full load resistance value and the current load resistance value, if the current load resistivity is maintained under the setting value for over 3 sec continuously, heater break alarm occurs. Output does not stop and operates normally.

$$\text{Current load resistivity}(\%) = \frac{\text{Full load resistance value}}{\text{Current load resistance value}} \times 100$$

## ◎ Full load auto recognition [F - L]

This function recognizes the load resistance value automatically. Turning on this function operates the load with 100% of output for approx. 3 sec and sets the load resistance value in the product automatically.

※ This is only for feedback control models.

- (A) Photoelectric Sensors
- (B) Fiber Optic Sensors
- (C) Door/Area Sensors
- (D) Proximity Sensors
- (E) Pressure Sensors
- (F) Rotary Encoders
- (G) Connectors/ Connector Cables/ Sensor Distribution Boxes/Sockets
- (H) Temperature Controllers
- (I) SSRs / Power Controllers
- (J) Counters
- (K) Timers
- (L) Panel Meters
- (M) Tacho / Speed / Pulse Meters
- (N) Display Units
- (O) Sensor Controllers
- (P) Switching Mode Power Supplies
- (Q) Stepper Motors & Drivers & Controllers
- (R) Graphic/ Logic Panels
- (S) Field Network Devices
- (T) Software

# SPR1 Series

## ◎ RMS display/control

SPR1 Series measures and displays RMS value for maintaining accuracy.

E.g.) At pure resistance load, when control input is 4-20mA, rating is 220V or 50A.

Control input	4mA	8mA	12mA	16mA	20mA	Unit
Amount of control input	0	25	50	75	100	%
Display voltage (normal control mode)	0	66	155	210	220	V
Display voltage (constant voltage feedback control mode)	0	55	110	165	220	V
Display current (constant current feedback control mode)	0	12	25	38	50	A

## ■ RS485 Communication Output

※Applicable for models with RS485 communication output through option output (SPR1-□□T□□).

Please refer to '■ Ordering Information'.

## ◎ Communication Specifications

Comm. protocol	Modbus RTU	Comm. speed	2400, 4800, 9600, 19200, 38400 bps
Connection method	RS485	Comm. response time	5 to 99ms (default: 20ms)
Application standard	Compliance with EIA RS485	Start bit	1-bit (fixed)
Max. connections	31 units (address: 1 to 99)	Data bit	8-bit (fixed)
Synchronization method	Asynchronous	Parity bit	None, Even, Odd
Comm. method	Two-wire half duplex	Stop bit	1-bit, 2-bit
Comm. distance	Max. 800m		

## ◎ Application of system organization

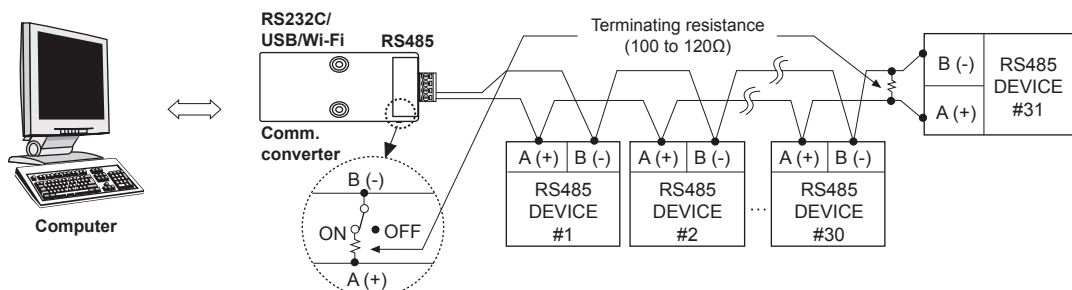

※It is recommended to use Autonics communication converter; SCM-WF48 (Wi-Fi to RS485-USB wireless communication converter, sold separately), SCM-US48I (USB to RS485 converter, sold separately), SCM-38I (RS232C to RS485 converter, sold separately). Please use twisted pair wire, which is suitable for RS485 communication, for SCM-WF48, SCM-US48I and SCM-38I.

## ■ Sold Separately

### ◎ Communication converter

- **SCM-WF48**  
(Wi-Fi to RS485-USB wireless communication converter)



- **SCM-US48I**  
(USB to RS485 converter)



- **SCM-38I**  
(RS232C to RS485 converter)



# LED Display, Single-Phase, Slim, Power Controller

## ■ Removing the Case

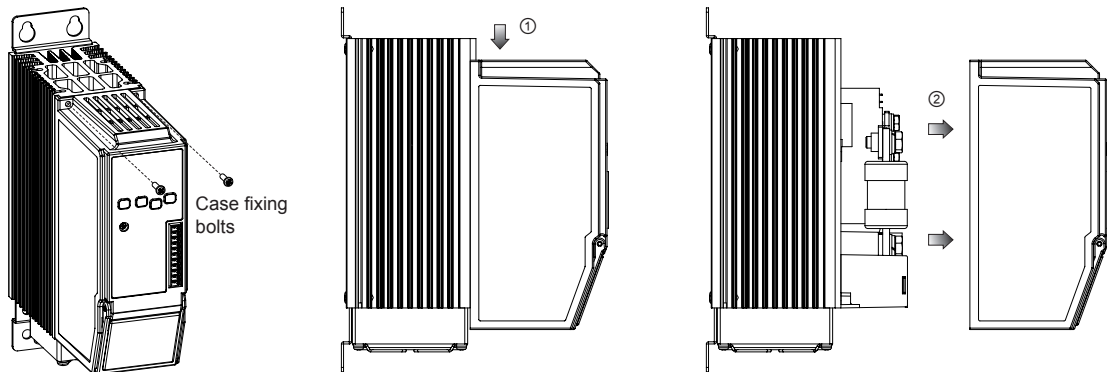

### • Spec. of case fixing bolts

Rated load current	Spec. of bolts
25A, 35A, 50A, 70A	M3
100A, 150A	M4

## ■ Replacement of Fuse

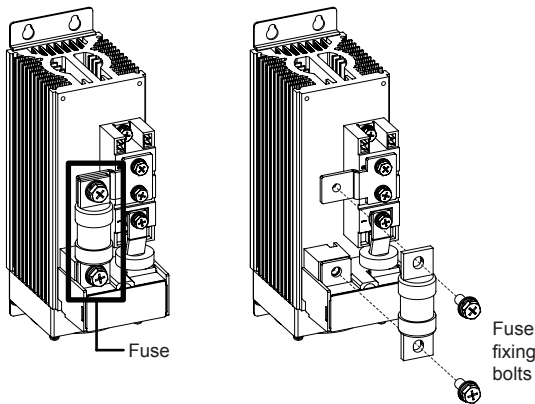

### • Spec. of fuse fixing bolts

Rated load current	Spec. of bolts
25A, 35A, 50A, 70A	M6
100A, 150A	M8

### • Recommended fuse specifications

For replacing the fuse, please use the recommended fuse which has the below specifications.

(manufacture: BUSSMANN)

Rated load current	Model	Rated load current	Model
25A	50FE	70A	100FE
35A	63ET	100A	FWH-150B
50A	80ET	150A	FWH-200B

※The performance of the product is guaranteed only when using the fuse provided by us.

## ■ Proper Usage

### ⚠ Cautions during use

- Follow instructions in 'Cautions during Use'. Otherwise, it may cause unexpected accidents.
- Use the product, after 3 sec of supplying power.
- Before use, set the mode and function according to the specification.  
Especially, be cautious that the product does not operate when OUT ADJ. is set to 0%. Since changing the mode/parameter during operation may result in malfunction, set the mode and function after disconnecting load output.
- Re-supply the power to the unit after the unit is discharged completely.  
Failure to follow this instruction may result in malfunction.
- To ensure the reliability of the product, install the product on the panel or metal surface vertically to the ground.
- Install the unit in the well ventilated place.
- While supplying power to the load or right after turning off the power of the load, do not touch the body and heat sink.  
Failure to follow this instruction may result in a burn due to the high temperature.
- Install a power switch or circuit breaker in the easily accessible place for supplying or disconnecting the power.
- Do not wire to terminals which are not used.
- Since inter element can be damaged when using with coil load, inductive load, etc., the inrush current must be under the rated load current.
- Do not use near the equipment which generates strong magnetic force or high frequency noise.
- This unit may be used in the following environments.

① Indoors (in the environment condition rated in 'Specifications')

② Altitude max. 2,000m

③ Pollution degree 2

④ Installation category III

(A) Photoelectric Sensors

(B) Fiber Optic Sensors

(C) Door/Area Sensors

(D) Proximity Sensors

(E) Pressure Sensors

(F) Rotary Encoders

(G) Connectors/ Connector Cables/ Sensor Distribution Boxes/Sockets

(H) Temperature Controllers

(I) SSRs / Power Controllers

(J) Counters

(K) Timers

(L) Panel Meters

(M) Tacho / Speed / Pulse Meters

(N) Display Units

(O) Sensor Controllers

(P) Switching Mode Power Supplies

(Q) Stepper Motors & Drivers & Controllers

(R) Graphic/ Logic Panels

(S) Field Network Devices

(T) Software