

# SSR Terminal Block (Common Type, 16/32-point)



## ASS Series PRODUCT MANUAL

For your safety, read and follow the considerations written in the instruction manual, other manuals and Autonics website.

The specifications, dimensions, etc. are subject to change without notice for product improvement. Some models may be discontinued without notice.

### Features

- Screw type connection for stable and reliable connection
- Contactless relay ideal for systems requiring long life-cycle and high-speed response
- Compact, space-saving design
- Comprehensive connection type for use without jumper bar
- Operation status indicator (blue LED)
- DIN rail mount and screw mount installation
- Convenient SSR removal with ejector clip
- SSR protection cover

※ Autonics CH/CO series I/O terminal block cables are recommended for best performance.

### Safety Considerations

- Observe all 'Safety Considerations' for safe and proper operation to avoid hazards.
- ⚠ symbol indicates caution due to special circumstances in which hazards may occur.

**⚠ Warning** Failure to follow instructions may result in serious injury or death.

**01. Fail-safe device must be installed when using the unit with machinery that may cause serious injury or substantial economic loss.** (e.g. nuclear power control, medical equipment, ships, vehicles, railways, aircraft, combustion apparatus, safety equipment, crime/disaster prevention devices, etc.)

Failure to follow this instruction may result in personal injury, economic loss or fire.

**02. Do not use the unit in the place where flammable/explosive/corrosive gas, high humidity, direct sunlight, radiant heat, vibration, impact or salinity may be present.**

Failure to follow this instruction may result in explosion or fire.

**03. Do not connect, repair, or inspect the unit, remove connector, or change SSR while connected to a power source.**

Failure to follow this instruction may result in fire or electric shock.

**04. Do not disassemble or modify the unit.**

Failure to follow this instruction may result in fire or electric shock.

**⚠ Caution** Failure to follow instructions may result in injury or product damage.

**01. Use the unit within the rated specifications.**

Failure to follow this instruction may result in fire or product damage.

**02. Use a dry cloth to clean the unit, and do not use water or organic solvent.**

Failure to follow this instruction may result in fire or electric shock.

**03. Keep the product away from metal chip, dust, and wire residue which flow into the unit.**

Failure to follow this instruction may result in fire or product damage.

**04. Do not use the product when a screw of terminal is loosened.**

Failure to follow this instruction may result in fire or product damage.

### Cautions during Use

- Follow instructions in 'Cautions during Use'. Otherwise, it may cause unexpected accidents.
- Check the polarity of power or COMMON before connecting PLC or other controllers.
- Do not touch the unit immediately after the load power is supplied or cut. It may cause burn by high temperature.
- 24VDC power supply should be insulated and limited voltage/current or Class 2, SELV power supply device.
- Wire as short as possible and keep away from high voltage lines or power lines, to prevent surge and inductive noise. Do not use near the equipment which generates strong magnetic force or high frequency noise (transceiver, etc.). In case installing the product near the equipment which generates strong surge (motor, welding machine, etc.), use diode or varistor to remove surge.
- This unit may be used in the following environments.
  - Indoors (in the environment condition rated in 'Specifications')
  - Altitude max. 2,000 m
  - Pollution degree 2
  - Installation category II

### Product Components

- Product
- Instruction manual
- Ejector

### Sold Separately

- I/O cable CH/CO Series

## Ordering Information

This is only for reference, the actual product does not support all combinations. For selecting the specified model, follow the Autonics website.

ASS - ① ② ③ ④ - ⑤ ⑥

### ① Connector type

H: Hirose connector

### ② Wire connection

C: Common

### ③ The number of SSR

16: 16-point

32: 32-point

### ④ SSR type

MPO: AQZ202D [Panasonic]

### ⑤ Input logic





N: NPN (+COM)

P: PNP (-COM)

### ⑥ Varistor

N: None

## Specifications

Model	ASS-HC16MPO-□N	ASS-HC32MPO-□N
Applied SSR <sup>(1)</sup>	AQZ202D [Panasonic]	
Output method	1a	1a
Power supply	≤ 24 VDC ≒ ±10 %	≤ 24 VDC ≒ ±10 %
Current consumption	≤ 10.4 mA <sup>(2)</sup> or ≤ 13.1 mA <sup>(3)</sup>	≤ 11.5 mA <sup>(2)</sup> or ≤ 15.3 mA <sup>(3)</sup>
SSR output rated spec.	24 VAC ~ 50/60 Hz 1.6A, 24 VDC ≒ 1.6A (1.6 A / 1-point, 8 A / 1COM)	24 VAC ~ 50/60 Hz 1.6A, 24 VDC ≒ 1.6A (1.6 A / 1-point, 8 A / 1COM)
No. of connector pins	20	40
Connector for controller side	20-pin Omron (XG4A-2031)	40-pin Hirose (HIF3BA-40PA-2.54DSA)
No. of SSR points	16	32
Output connection	8-point/1COM	8-point/1COM
Terminal type	Screw	Screw
Terminal pitch	7.62 mm	7.62 mm
Indicator	Power indicator: red, operating indicator: blue	Power indicator: red, operating indicator: blue
Varistor	None	None
Input logic	NPN / PNP model	NPN / PNP model
Material	CASE, BASE, COVER: PC, terminal pin: brass, Ni-plating	CASE: MPPO, BASE: PA66 (G25%), COVER: PC, terminal pin: brass, Ni-plating
Approval	CE  	CE  
Unit weight (packaged)	≈ 185 g (≈ 232 g)	≈ 370 g (≈ 463 g)

(1) For the detailed information about the SSR, please refer to 'SSR' or data sheet from the manufacturer.

(2) It is current consumption per a SSR including LED current.

(3) It is current consumption including LED current for power part to (2).

Insulation resistance	≥ 1,000 MΩ (500 VDC ≒ megger)
Dielectric strength (coil-contact)	2,500 VAC ~ 50/60 Hz for 1 minute
Dielectric strength (same polarity contact)	1,000 VAC ~ 50/60 Hz for 1 minute
Vibration	0.75mm amplitude at frequency of 10 to 55Hz in each X, Y, Z direction for 2 hours
Vibration (malfunction)	0.75mm amplitude at frequency of 10 to 55Hz in each X, Y, Z direction for 10 min
Shock	300 m/s <sup>2</sup> (≈ 30 G) in each X, Y, Z direction for 3 times
Shock (malfunction)	150 m/s <sup>2</sup> (≈ 15 G) in each X, Y, Z direction for 3 times
Ambient temperature	-15 to 55 °C, storage: -25 to 65 °C (no freezing or condensation)
Ambient humidity	35 to 85 %RH, storage: 35 to 85 %RH (no freezing or condensation)
Applicable wire - solid	∅0.3 to ∅1.2 mm
Applicable wire - stranded	AWG 22-16 (0.30 to 1.25 mm <sup>2</sup> )
Tightening torque	0.5 to 0.6 N · m

## Crimp Terminal Specifications

• Unit: mm, Use the UL approved crimp terminal.

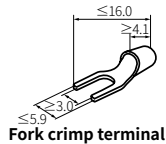

Fork crimp terminal

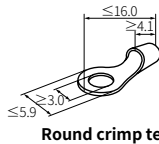

Round crimp terminal

## Replacing SSR

1. Disassemble a SSR by using Two Way Ejector for SSR replacement inside the product.



[Ejector]

2. After checking the location of the SSR socket, insert the SSR to be replaced.

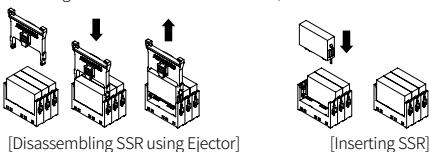

[Disassembling SSR using Ejector]

[Inserting SSR]

## Dimensions

• Unit: mm, For the detailed drawings, follow the Autonics website.

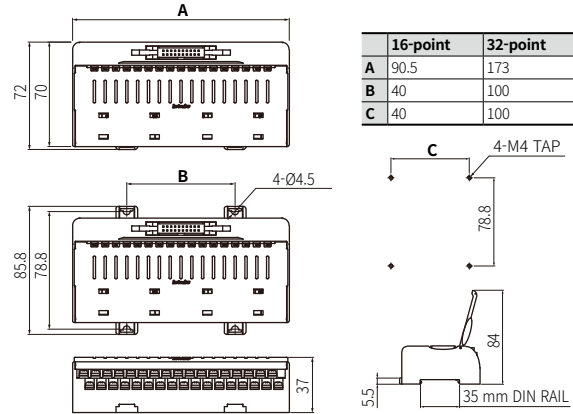

## Installation

### ■ DIN Rail

• Mounting

1. Pull the Rail lock on the rear of the product to the direction ①.
2. Hang DIN rail hook on the rear of the product onto DIN rail.
3. Push the product to the direction ②, and push the Rail lock to the direction ③ to fix onto the DIN rail.

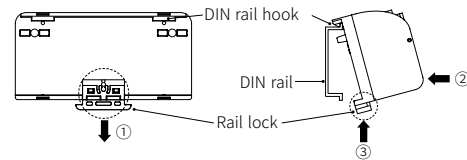

• Removing

1. Insert a tool such as screwdriver into the hole of Rail lock.
2. Push the tool to the direction ① and pull the Rail lock.
3. Lift bottom of the product to the direction ② and remove the product from DIN rail.

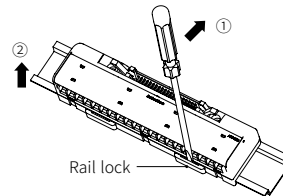

### ■ Panel

Product with the mounting hole can be installed on panel with screw.

It is recommended to use M4 × 15 mm of spring washer screws.

If you use flat washer, its diameter should be ∅ 6 mm.

Tighten the screw with the tightening torque of 0.7 to 1.0 N · m.

### ■ Example

- When two or more terminal blocks are installed  
: Use a stopper (sold separately) to make space between devices.

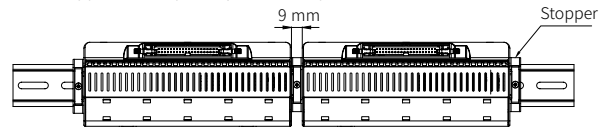

## Temperature Characteristic Graph

• Load current by ambient temperature for each rated current

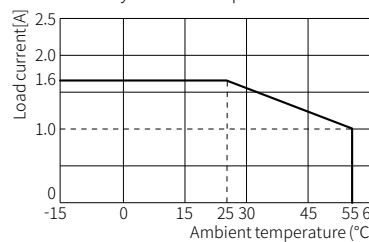

$V_{IN}$ : 24 VDC ≒

•  $V_{IN}$  is input voltage.

## Wire Connection

### ■ Wire connection

- 16-point NPN

Controller side (connector)

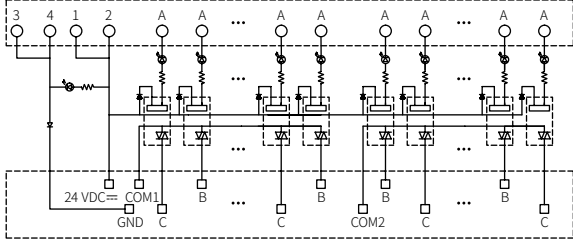

Terminal side

- 16-point PNP

Controller side (connector)

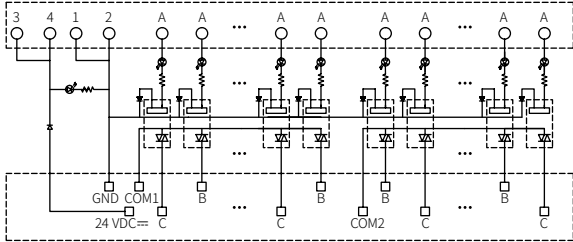

Terminal side

A	Pin	20	18	16	14	12	10	8	6	19	17	15	13	11	9	7	5
COM	COM	COM1								COM2							
B	Upper terminal	-	R2	-	R4	-	R6	-	R8	R9	-	R11	-	R13	-	R15	-
C	Low terminal	00	-	02	-	04	-	06	-	09	-	0B	-	0D	-	0F	-
		R1	-	R3	-	R5	-	R7	-	R10	-	R12	-	R14	-	R16	-

- 32-point NPN

Controller side (connector)

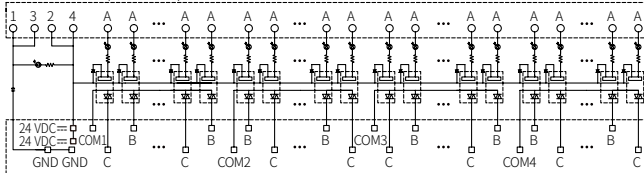

Terminal side

- 32-point PNP

Controller side (connector)

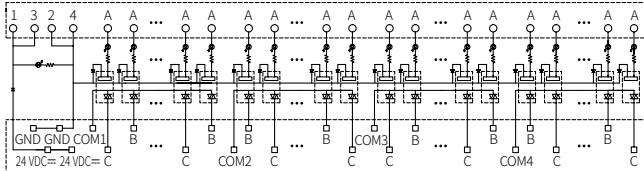

Terminal side

A	Pin	40	38	36	34	32	30	28	26	24	22	20	18	16	14	12	10	
COM	COM	COM1										COM2						
B	Upper terminal	-	01	-	03	-	05	-	07	08	-	0A	-	0C	-	0E	-	
C	Low terminal	00	-	02	-	04	-	06	-	09	-	0B	-	0D	-	0F	-	
		R1	-	R3	-	R5	-	R7	-	R10	-	R12	-	R14	-	R16	-	

  

A	Pin	39	37	35	33	31	29	27	25	23	21	19	17	15	13	11	9	
COM	COM	COM3										COM4						
B	Upper terminal	-	11	-	13	-	15	-	17	18	-	1A	-	1C	-	1E	-	
C	Low terminal	10	-	12	-	14	-	16	-	19	-	1B	-	1D	-	1F	-	
		R17	-	R19	-	R21	-	R23	-	R26	-	R28	-	R30	-	R32	-	

### ■ Hirose connector pin arrangement

- 20-pin connector

Omron (XG4A-2031)

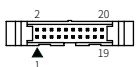

- 40-pin connector

Hirose (HIF3BA-40PA-2.54DSA)



## SSR AQQ202D [Panasonic]

### ■ Input

Rated voltage	Operate voltage	Release voltage	Input impedance
30 VDC≒	≥ 4 V	≤ 1.3 V	-

### ■ Output

Manufacture	Panasonic
Contact arrangement	SPST-1a (N.O)
Load voltage range	60 VAC~ / DC≒ (Peak)
Max. load current	≤ 2.7 A
Min. load current	-
Non-repetitive surge current	9 A (Peak)
Output OFF leakage current	10 μA
Output ON on voltage	-
Insulation resistance	≥ 1,000 MΩ (500 VDC≒ megger)
Dielectric strength (contact-coil)	2,500 VAC~ / 50/60 Hz for 1 minute
Operate time	≤ 10 ms
Release time	≤ 3 ms
Ambient temperature	-40 to 60 °C, storage: -40 to 100 °C (a non freezing or condensation environment)

### ■ Dimensions

- unit: mm

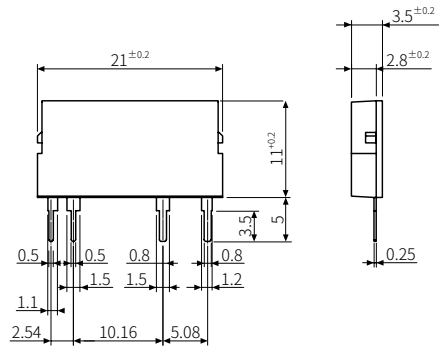

- Circuit diagram (bottom view)

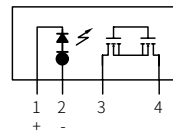

- PCB pattern

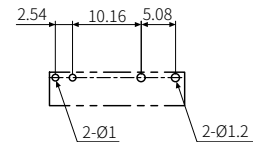

It was written based on the data provided by each manufacturer, but there is room for change, so be sure to check the manufacturer's data.