

PUMPING HAPPINESS INTO INDIAN HOMES

DOMESTIC WATER CATALOGUE



GRUNDFOS 

Purpose and Values

We pioneer solutions to the world's water and climate challenges and improve the quality of life for people.



CONTENTS

PRESSURE BOOSTING

CM BOOSTER
CMB WITH PM1
CM TWIN BOOSTER
SCALA1
SCALA2
CME BOOSTER
CMBE TWIN BOOSTER
UPA

WATER TRANSFER

SmART SUB
JP
SB
SP
SQE

PRESSURE MANAGER

PRESSURE MANAGER- PM RANGE
PRESSURE TANK (GT)

CIRCULATION PUMPS

COMFORT UP
MAGNA3
CM
UPS

DRAINER PUMPS

KPC SERIES
UNILIFT CC
UNILIFT KP
UNILIFT AP
SEG GRINDER

LIFTING STATIONS

SOLOLIFT2
MULTILIFT MSS

CONTROL PANELS

GIDPC DOT
GIDPC SINGLE PHASE
GIDPC THREE PHASE
GIDPC Pro





PRESSURE BOOSTING

CM BOOSTER

GRUNDFOS CM DOMESTIC WATER PRESSURE BOOSTER PUMP

THE MOST ROBUST PUMP DESIGNED FOR WATER PRESSURE BOOSTING

The Grundfos CMB with PT is a compact booster pump designed for domestic and light commercial use. The booster unit consists of a Grundfos CM pump with stainless steel hydraulic components and a pressure tank.

The CM pump is supplied with a pressure tank for even distribution of water pressure. When the water demand increases, there will be a pressure drop in the pipeline from the pre-set level. The pump automatically starts till it reaches pre-set cut-off pressure. The systems are available with 24 Lts & 60 Lts pressure tank.

CONSTRUCTION

- Electro-coated cast iron parts free from corrosion
- High efficient motor
- Horizontal multi-stage centrifugal pump
- Long life components are of corrosion and wear resistance stainless steel

APPLICATIONS

- Mains boosting
- Household water supply
- Boosting from above ground water tanks

FEATURES

- Silent operation, compact design and highly reliable
- Wide performance range
- Liquid temperature from 20 °C up to 120 °C (pump only)
- Built-in thermal protection
- F class installation
- 100 Start / Stop Per hour



PRODUCT RANGE

Part Code	Model	Pressure Tank	Power		Voltage	FLOW	Hydraulic Data							Pipe Size (mm)	
			Kw	Hp		M ³ /hr	0	0.4	0.8	1.2	1.6	2	2.4	Suction	Delivery
						LPM	0	6.6	13.3	20	26.6	33.3	40		
96939705	CMB1-18	24 Lts	0.3	0.4	1 X 220-240	Head (Mts)	18	17	16	14.5	12.5	10	7	25	25
96939707	CMB 1-36	24 Lts	0.5	0.7	1 X 220-240		36	34.5	32	28.5	24.5	19.5	14	25	25
96939709	CMB 1-54	24 Lts	0.5	0.7	1 X 220-240		53.5	51	47	42	35	28	20	25	25
Part Code	Model	Pressure Tank	Power		Voltage	M ³ /hr	0	0.8	1.6	2	2.4	3.2	4	Suction	Delivery
			LPM	0		13.3	26.6	33.3	40	53.3	66.6				
96939712	CMB 3-18	24 Lts	0.3	0.4	1 X 220-240	Head (Mts)	18.5	17.5	16.5	16	15	13	10	25	25
96939713	CMB 3-27	24 Lts	0.5	0.7	1 X 220-240		28	26.5	25	24	23	19.5	15	25	25
96939714	CMB 3-37	24 Lts	0.5	0.7	1 X 220-240		37	35	33	31	30	25	19	25	25
96939715	CMB 3-46	24 Lts	0.5	0.7	1 X 220-240		46	43.5	40	38	35.5	29.5	22	25	25
96939769	CMB 3-46	60 Lts	0.5	0.7	1 X 220-240		46	43.5	40	38	35.5	29.5	22	25	25
96939716	CMB 3-55	24 Lts	0.7	0.9	1 X 220-240		56	53	49	46.5	43.5	37	27	25	25
96939770	CMB 3-55	60 Lts	0.7	0.9	1 X 220-240		56	53	49	46.5	43.5	37	27	25	25
Part Code	Model	Pressure Tank	Power		Voltage		M ³ /hr	0	1	2	3	4	5	6	Suction
			LPM	0		16.6	33.3	50	66.6	83.3	100				
96939719	CMB5-18	24 Lts	0.5	0.7	1 X 220-240	Head (Mts)	19	18	17	16	15	13.5	11	32	25
96939720	CMB 5-28	24 Lts	0.5	0.7	1 X 220-240		28	26.5	25.5	24	22	19	15	32	25
96939721	CMB 5-37	24 Lts	0.7	0.9	1 X 220-240		38	36	34	32	30	26	20	32	25
96939775	CMB5-37	60 Lts	0.7	0.9	1 X 220-240		38	36	34	32	30	26	20	32	25
96939722	CMB 5-46	24 Lts	0.9	1.2	1 X 220-240		47.5	45.5	43.5	41.5	38.5	34	26.5	32	25
96939776	CMB 5-46	60 Lts	0.9	1.2	1 X 220-240		47.5	45.5	43.5	41.5	38.5	34	26.5	32	25
96939723	CMB 5-56	24 Lts	1.3	1.7	1 X 220-240		57.5	56	54	51	47.5	41.5	33	32	25
96939777	CMB 5-56	60 Lts	1.3	1.7	1 X 220-240		57.5	56	54	51	47.5	41.5	33	32	25
Part Code	Model	Pressure Tank	Power		Voltage	M ³ /hr	0	3	6	8	10	12	14	Suction	Delivery
			LPM	0		50	100	133.3	166.6	200	233.3				
99300284	CMB 10-32	100 Lts	1.3	1.7	1 X 220-240	Head (Mts)	32.5	32	30	28	25	21	17	40	40
On Request	CMB 10-47	100 Lts	1.7	2.3	1 X 220-240		47	46	43	39.5	35	30	24	40	40
Part Code	Model	Pressure Tank	Power		Voltage	FLOW	Hydraulic Data							Pipe Size (mm)	
			Kw	Hp		M ³ /hr	0	0.4	0.8	1.2	1.6	2	2.4	Suction	Delivery
						LPM	0	6.6	13.3	20	26.6	33.3	40		
96939706	CMB 1-27	24 Lts	0.3	0.4	1 X 220-240	Head (Mts)	27	26	24	21	18	14.5	10.5	25	25
96939708	CMB 1-45	24 Lts	0.5	0.7	1 X 220-240		44.5	43	39.5	35	30	24	17	25	25

For all pumps, electrical supply is 1 phase 200-240 Volts AC, 50 Hz

CMB WITH PM1

The Grundfos CMB with PM1 is a compact booster pump designed for domestic and light commercial use. The booster unit consists of a Grundfos CM pump with stainless steel hydraulic components and a PM1 Pressure Manager.

The Pressure Manager allows the pump to start and stop automatically according to demand and protects the pump from drying up.

FEATURES

Robust design

All the movable parts are made of high quality, corrosion-resistant stainless steel to ensure the longest life possible

User-friendly interface

The pump features a user-friendly interface with LED indicators displaying power status, pump running, and alarm indication

Protective features

The pump incorporates a range of protective features such as dry run protection, thermal overload protection, cycling alarm to protect the pump and ensuring a long life

Easy installation

The booster unit is a compact solution, which makes it suitable for most installations. Just connect the inlet and outlet, and you have a fully operational booster unit

Integrated non-return valve

Non-return valve for back-flow prevention



APPLICATIONS

- Mains boosting
- Household water supply
- Boosting from above ground water tanks

PRODUCT RANGE

Part Code	Model	Cut-in pressure (BAR)	Power		FLOW	Hydraulic Data							Pipe Size (mm)	
					M ³ /hr	0	0.4	0.8	1.2	1.6	2	2.4	Suction	Delivery
			Kw	Hp	LPM	0	6.6	13.3	20	26.6	33.3	40		
97530099	CMB1-36	1.5	0.5	0.7	Head (Mts)	36	34.2	32	28.5	24.5	19.5	14	25	25
Part Code	Model	Cut-in pressure (BAR)	Power		M ³ /hr	0	0.8	1.6	2	2.4	3.2	4	Suction	Delivery
			Kw	Hp	LPM	0	13.3	26.6	33.3	40	53.3	66.6		
97530126	CMB 3-37	1.5	0.5	0.7	Head (Mts)	28	26.5	25	24	23	19.5	15	25	25
97530135	CMB 3-47	2.2	0.5	0.7		37	35	33	31	30	25	19	25	25
97530144	CMB 3-46	2.2	0.5	0.7		46	43.5	40	38	35.5	29.5	22	25	25
Part Code	Model	Cut-in pressure (BAR)	Power		M ³ /hr	0	1	2	3	4	5	6	Suction	Delivery
			Kw	Hp	LPM	0	16.6	33.3	50	66.6	83.3	100		
97687683	CMB5-28	1.5	0.5	0.7	Head (Mts)	28	26.5	25.5	24	22	19	15	32	25
97687685	CMB 5-37	2.2	0.7	0.9		38	36	34	32	30	26	20	32	25
97530169	CMB 5-46	2.2	0.9	1.2		47.5	45.5	43.5	41.5	38.5	34	26.5	32	25
Part Code	Model	Cut-in pressure (BAR)	Power		FLOW	Hydraulic Data							Pipe Size (mm)	
					M ³ /hr	0	0.4	0.8	1.2	1.6	2	2.4	Suction	Delivery
			Kw	Hp	LPM	0	6.6	13.3	20	26.6	33.3	40		
97530090	CMB 1-27	1.5	0.3	0.4	Head (Mts)	27	26	24	21	18	14.5	10.5	25	25
97530108	CMB 1-5	2.2	0.5	0.7		44.5	43	39.5	35	30	24	17	25	25

For all pumps, electrical supply is 1 phase 200-240 Volts AC, 50 Hz

CM TWIN BOOSTER

The Grundfos CM Twin Booster set consists of two identical Grundfos CM pumps connected in parallel and mounted on a common base frame and a control cabinet incorporating motor protection and controller.

APPLICATIONS

- Large houses
- Domestic buildings
- Cottages and villas
- Mid-size Hotels
- Mid-size Hospitals
- Schools

FEATURES

- Non self priming, horizontal, multistage centrifugal pump
- Enclosure Class: IP 54
- Insulation Class: F
- Automatic start/stop up to 100 times/hour
- Quiet operation
- Paint application by electrophoresis gives the motor and pump CI parts, excellent corrosion resistance
- Simple control and alteration between pumps, dry running protection, built in relay for ensuring constant and steady operation



TWIN SYSTEM INCLUDES

- Suction and discharge manifolds
- Isolating valves
- Non- return valves
- Pressure gauge
- Pressure switch
- Grundfos Controller CS 201 (1 Phase)

CONSTRUCTION

- Pump Shaft : AISI 304
- Chamber : AISI 304
- Impeller : AISI 304
- Inlet & outlet parts : Cast iron
- Manifold : MS CED Coated

PRODUCT RANGE

Part Code	Model	Power (each pump)		2 Pump Flow	Hydraulic Data							Manifold Size (mm)	
		Kw	Hp	M ³ /hr	0	0.8	1.6	2.4	3.2	4	4.8	Suction	Delivery
				LPM	0	13.2	26.6	40	53.2	66.6	80		
97976148	CM1-3 TWIN	0.3	0.4	Head (Mts)	27	26	24	21	18	14.5	10.5	50	50
97976163	CM1-4 TWIN	0.5	0.7		36	34.5	32	28.5	24.5	19.5	14	50	50
97976165	CM1-5 TWIN	0.5	0.7		44.5	43	39.5	35	30	24	17	50	50
97976167	CM1-6 TWIN	0.5	0.7		53.5	51	47	42	35	28	20	50	50
Part Code	Model	Kw	Hp	M ³ /hr	0	1.6	3.2	4	4.8	6.4	8	Suction	Delivery
				LPM	0	26.6	53.2	66.6	80	106.3	133.2		
97952476	CM3-4 TWIN	0.5	0.7	Head (Mts)	37	35	33	31	30	25	19	50	50
97939873	CM3-5 TWIN	0.5	0.7		46	43.5	40	48	35.5	29.5	22	50	50
97952475	CM3-6 TWIN	0.7	0.9		56	53	49	46.5	43.5	37	27	50	50
Part Code	Model	Power		M ³ /hr	0	2	4	6	8	10	12	Suction	Delivery
		Kw	Hp	LPM	0	33.2	66.6	100	133.2	166.6	200		
97919519	CM 5-3 TWIN	0.5	0.7	Head (Mts)	28	26.5	25.5	24	22	19	15	50	50
97924082	CM 5-4 TWIN	0.7	0.9		38	36	34	32	30	26	20	50	50
97924086	CM 5-5 TWIN	0.9	1.2		47.5	45.5	43.5	41.5	38.5	34	26.5	50	50
97934433	CM 5-6 TWIN	1.3	1.7		57.5	56	54	51	47.5	41.5	33	50	50
Part Code	Model	Power		M ³ /hr	0	6	12	16	20	24	28	Suction	Delivery
		Kw	Hp	LPM	0	100	200	266.6	333.2	400	466.7		
97917472	CM 10-2 TWIN	1.3	1.7	Head (Mts)	32.5	32	30	28	25	21	17	75	75
97939823	CM 10-3 TWIN	1.7	2.3		47	46	43	39.5	45	30	24	75	75

For all pumps, electrical supply is 1 phase 200-240 Volts AC, 50 Hz

SCALA1

Getting water on Demand has never been easier

Grundfos SCALA1 is an all-in-one pressure boosting unit with a high-efficiency motor and hydraulics with low noise operation for domestic water supply and also light commercial applications. Built-in Bluetooth communication gives you complete control over the pump using the Grundfos GO REMOTE, also for twin pump operation.

This means that installation and commissioning has never been easier. The Grundfos GO REMOTE app also lets you see alarm status and get easy pump diagnostics. You can create and email reports on-site and access hard-to-reach installations remotely from the app.



Pressure boosting, control and water supply made easy

- **All-in-one booster unit**
Complete all-in-one unit, integrating pump, motor, diaphragm tank, pressure and flow sensor, dry-running protection, controller and non-return valve provides you with optimal pressure boosting for water on demand and intelligent pump control
- **Installation and commissioning**
Save time installing SCALA1 – simply connect the pipes, prime the pump and plug it in. For fast and easy commissioning, configure the pump quickly and intuitively directly from the pump control panel. For more advanced settings you can use the Grundfos GO and follow the guided online configuration
- **Bluetooth communication built-in**
The built-in two-way communication system connects to the intuitive Grundfos GO REMOTE app, which enables you to monitor, trouble-shoot and control SCALA1 from your smartphone. You can download the Grundfos GO REMOTE app to any device with an iOS or Android operating system
- **Easy twin pump control**
Built-in multi-pump/booster technology enables twin pump connection with joint pump control in either duty/ assist or duty/ standby mode. Online configuration is done easily using the Grundfos GO REMOTE app, where you can also adjust the alternation setup

APPLICATIONS

- Taps and showers in the home
- Garden and lawn irrigation
- Greenhouses
- Water transfer
- Car wash

TECHNICAL DATA

- Max ambient temperature - 55 °C / 131 °F
- Max liquid temperature - 45 °C / 113 °F
- Max system pressure - 8 bar / 115 psi
- Frequency of start / stop - 25 per hour
- IP rating - X4D (outdoor use ready)
- Pumped liquid - Clean water
- Noise level - < 55 dB(A)
- Safety approvals - CE, EAC
- Drinking water approvals - ACS

Five size variants for every domestic water supply need

Designed for pressure boosting in domestic installations, use SCALA1 for pumping from a roof tank, break tank or ground tank. It is also ideal for water supply from shallow wells (less than 8 m) and for pressure boosting from city mains water.

Part Code	Model	Power		Cut-in Pressure (BAR)	Voltage	FLOW	Hydraulic Data							Pipe Size (mm)		
		Kw	Hp				M ³ /hr	0	0.8	1.6	2.4	3	3.8	4.8	Suction	Delivery
								LPM	0	13.3	26.7	40.0	50.0	63.3		
99530408	SCALA1 3-25	0.36	0.5	1.2	1x230 V	Head (Mts)	25	24	23	21	19	16	11	25	25	
99530409	SCALA1 3-35	0.45	0.6	1.5	1x230 V		36	35	32	28	25	19	11	25	25	
99530410	SCALA1 3-45	0.58	0.8	2.2	1x230 V		44	41	38	33	30	23	14	25	25	
Part Code	Model	Power		Cut-in Pressure (BAR)	Voltage	FLOW	Hydraulic Data							Pipe Size (mm)		
		Kw	Hp				M ³ /hr	0	1	2	3	4	5	6	Suction	Delivery
								LPM	0	16.7	33.3	50.0	66.7	83.3		
99530411	SCALA1 5-25	0.43	0.6	1.2	1x230 V	Head (Mts)	26	25	23	20	17	13	8	25	25	
99530412	SCALA1 5-55	0.78	1	2.8	1x230 V		52	49	45	40	35	27	19	25	25	
MANIFOLD FOR SCALA1 TWIN											Manifold Size (mm)					
											Suction	Delivery				
99725165	SCALA1 TWIN ACCESSORIES SET										32	32				

DIMENSIONS

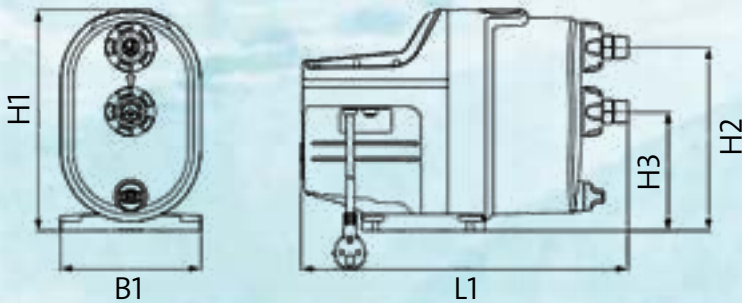

Pos.	H1 (mm) (inch)	H2 (mm) (inch)	H3 (mm) (inch)	L1 (mm) (inch)	B1 (mm) (inch)
SCALA1 (all variants)	316 12.4	263 10.4	171 6.7	466 18.4	202 8.0

Scala1 Twin Accessories Set

If greater flow is required, this is easily done in a twin pump setup with the available accessories (including baseplate, cable and inlet and outlet manifolds). You can then follow the guided online configuration using the Grundfos GO REMOTE app.



SCALA2

The Grundfos SCALA2 is a fully integrated water booster pump delivering perfect water pressure in all taps at all times - even with multiple taps and showers running at the same time. It packs a pump, motor, tank, sensor, drive and non-return valve into one compact unit. With its intelligent pump control, SCALA2 automatically adjusts performance to both inlet pressure and water consumption in the home. SCALA2 has a sound level of 47 dB (A) in typical use and thereby offers one of the lowest noise levels of any booster in the market.



FEATURES

Perfect water pressure - in all taps at all times

SCALA2 has an intelligent pump control that always ensures constant pressure by detecting any variation in water and inlet pressure.

It immediately adjusts its operation to deliver the required discharge pressure. SCALA2 will maintain sufficient water pressure

Low noise

SCALA2 has a water cooled, high-efficiency permanent magnet motor that ensures a low noise operation at 47 db(A) in typical use. SCALA2 is as quiet as a modern dishwasher and one of the most quiet boosters in its class

Compact

SCALA2 is a fully integrated solution with pump, tank, sensor, drive and non-return valve in one unit that will fit in any existing installation and in compact spaces like a kitchen cupboard. It weighs only 10 kg and is easy to handle

Robust and reliable

SCALA2 offers a long lifetime. It can even be installed outside. It's made of quality materials and has protective measures like dry-run protection and anti-cycling

Easy installation and self-priming

SCALA2 is an all-in-one solution designed for fast and easy installation. Simply connect the pipes, prime the pump and connect to the power. It has a large priming hole, which makes it easy to prime

Energy efficient

SCALA2 features a high efficient permanent magnet motor using only 550 W (Power input max (P1)) and has a power consumption of only 270 W in daily use (3 bar/12 l/min)



OPERATING CONDITIONS

Max. ambient temperature	55 °C (131 °F)
Max. liquid temperature	45 °C (113 °F)
Max. system pressure	10 bar (145 PSI, 1 MPa)
Max. inlet pressure	6 bar (87 PSI, 0.6 MPa)
Max. head	45 m (147 feet)
Pumped liquid	Clean, fresh water and chlorinated water < 300 ppm

PERFORMANCE CURVE

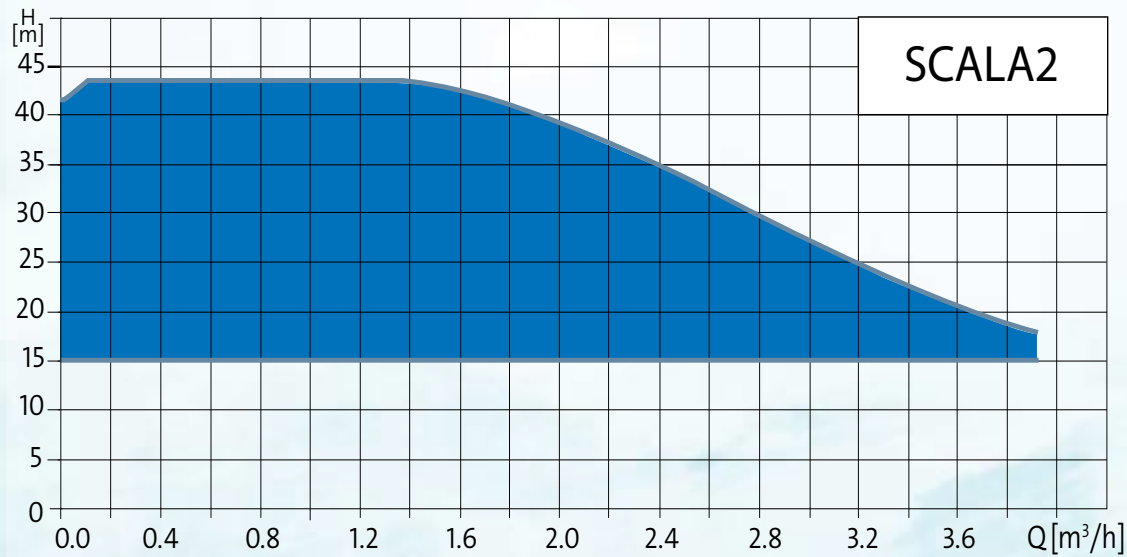

DIMENSIONS PICS

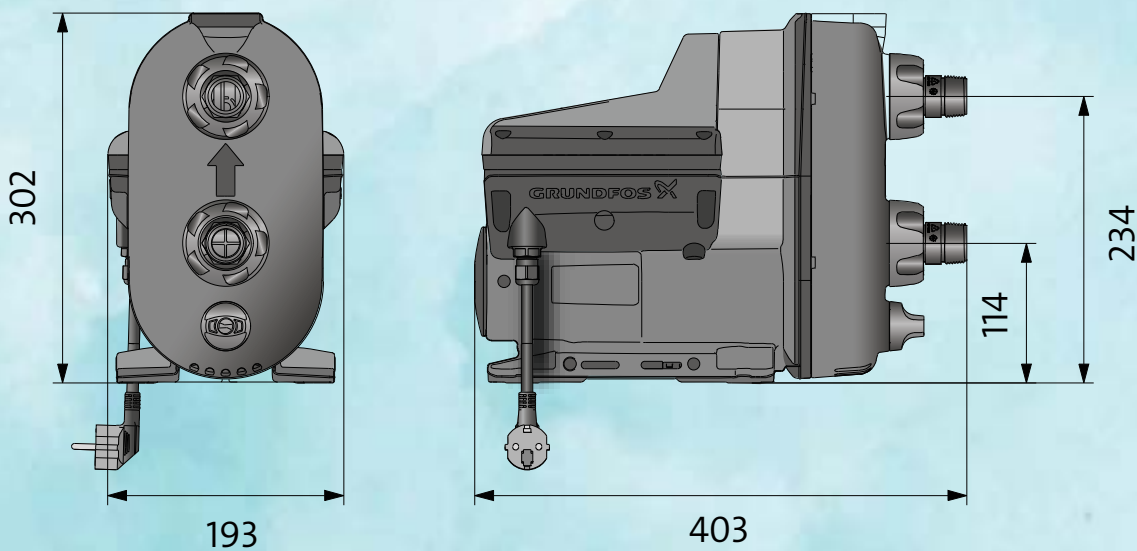

All dimensions in mm

PRODUCT RANGE

Part Code	Model	Power		Weight [kg]
		kw	Hp	
98562862	SCALA2 3-45	0.55	0.7	10

CME BOOSTER

The Grundfos CME Booster is a compact, frequency (VFD) controlled booster system for a large variety of domestic and light commercial applications. The CME Booster ensures great comfort by providing constant pressure, regardless of variations in demand or inlet pressure. In addition, the CME Booster makes it possible to adjust the water pressure just by the touch of a button. Also, the CME Booster is very easy to install. Once the booster has been connected to the pipeline, it is simply a matter of putting the plug into a socket, and the system is operational.

APPLICATIONS

- Large houses
- Domestic buildings
- Cottage and villas
- Mid-size Hotels
- Mid-size Hospitals
- Schools

FEATURES

- **Constant pressure**
The CME Booster always provides constant pressure
- **Robust design**
The pump is made of materials that ensure excellent corrosion resistance. The pump housing, shaft and impeller are made of high quality stainless steel, while the rest of the pump is electrophoretically painted
- **Energy saving**
The frequency controller of the CME Booster, matches the power consumption with the required water output, which can save users up to 40% power
- **Fully equipped**
The CME Booster has a five-way fitting that encompasses a non-return valve, a pressure sensor, a pressure gauge and a diaphragm tank connection
- **Low noise**
The CME Booster operates quietly at around 55 decibels, which is significantly silent than most pumps currently available in the market
- **User-friendly interface**
The control panel on the pump features a user-friendly interface with LED indicators showing operational status and feather touch buttons for pressure adjustment
- **Dry-running protection**
The CME Booster automatically stops if there is no water from the incoming pipeline
- **Thermal overload protection**
The CME Booster is effectively protected against any accidental overload by built-in thermal protection



The control panel on the pump terminal box makes it possible to change the set-points manually.



The operating condition of the pump is indicated by the Grundfos Eye on the control panel.

OPERATING CONDITIONS

- **System pressure**
Max. 10 bar
- **Liquid temperature**
0 °C to +60 °C
- **Ambient temperature**
Max. +55 °C
- **Relative air humidity**
Max. 95%
- **Mains voltage**
1 x 200 -240V 50/60 Hz
- **Enclosure class**
IP55
- **Sound pressure level**
50-65 dB(A)
- **Approvals and markings**
CE, EAC, UL, WRAS, ACS, NSF61

PERFORMANCE CURVE

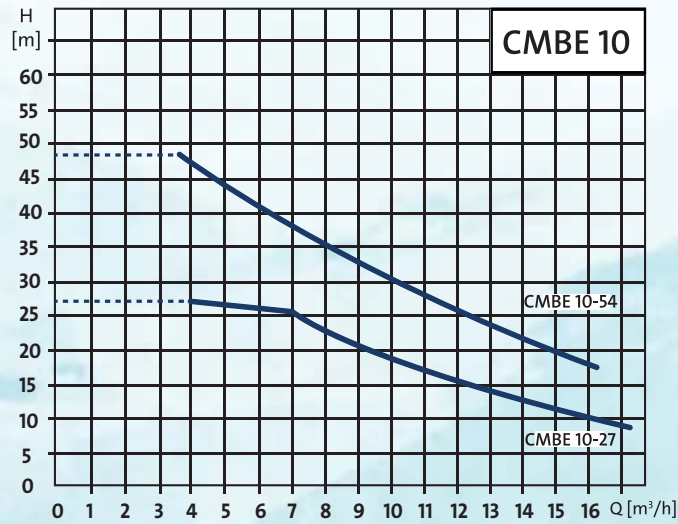
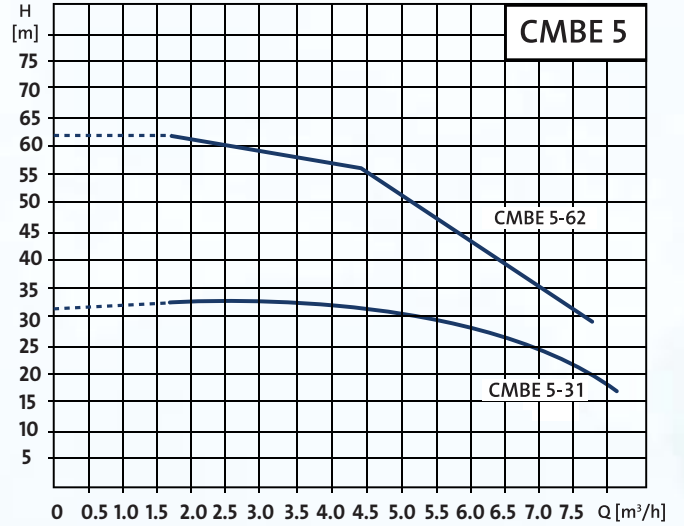
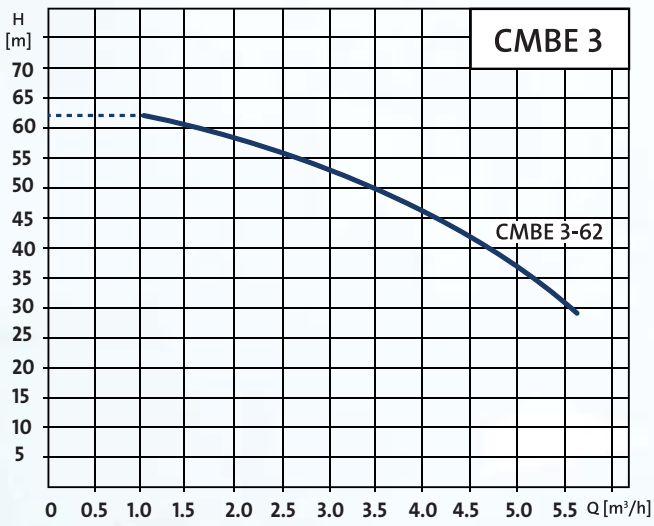

PRODUCT RANGE

Part Code	Model	Power		Voltage	Pipe Size (mm)	
		Kw	Hp		Suction	Delivery
98374693	CMBE 3-62	1.1	1.5	1 x 200-240	25	25
98374695	CMBE 5-31	1.1	1.5	1 x 200-240	40	25
98374696	CMBE 5-62	1.5	2	1 x 200-240	40	25
98382189	CMBE 10-27	1.1	1.5	1 x 200-240	40	40
98382190	CMBE 10-54	1.5	2	1 x 200-240	40	40

For all pumps, electrical supply is 1 phase 200-240 Volts AC, 50 Hz

CMBE TWIN BOOSTER

The Grundfos CMBE TWIN Booster is a compact two-pump booster system for water supply in domestic and light commercial applications that are easy to install and commission. The integrated speed controller allows the CMBE Booster to maintain constant pressure in the pipeline. A pressure sensor monitors the changes in water consumption and will signal the speed controller to change the motor speed. This way, performance is adjusted automatically. The cascade control ensures that the performance of the CMBE Booster is automatically adapted to the consumption pattern by switching pumps on or off between 2 pumps, or by changing the speed of the pumps. The system thus runs energy-efficiently with a limited number of pumps.



FEATURES

- **Constant pressure**
The integrated speed controller keeps a constant pressure in the pipe system
- **Cascade control**
Cascade control ensures that the performance of the booster system is automatically adapted to the consumption by switching between the pumps on/off
- **Pump alternation**
Pump alternation ensures that the operating hours are distributed evenly on the pumps over time
- **Dry-running protection**
The system will stop automatically if there is no water from the incoming pipeline
- **Easy installation**
The booster is easy to install when it is connected to pipes. It is a matter of Plug & Play

OPERATING CONDITIONS

- **System pressure**
Max. 10 bar
- **Liquid temperature**
0°C to +60 °C
- **Ambient temperature**
Max. +55 °C
- **Relative air humidity**
Max. 95%
- **Mains voltage**
1 x 200 -240 V 50/60 Hz
- **Enclosure class**
IP55
- **Sound pressure level**
50-65 dB(A)
- **Approvals and markings**
CE, EAC, UL, WRAS, ACS, NSF61

APPLICATIONS

- Large houses
- Domestic buildings
- Cottage and villas
- Mid-size Hotels
- Mid-size Hospitals
- Community hostels
- Schools
- Poly-house & Green House farming



The control panel on the pump terminal box makes it possible to change the set-points manually. The operating condition of the pump is indicated by the Grundfos Eye on the control panel.

PERFORMANCE CURVE

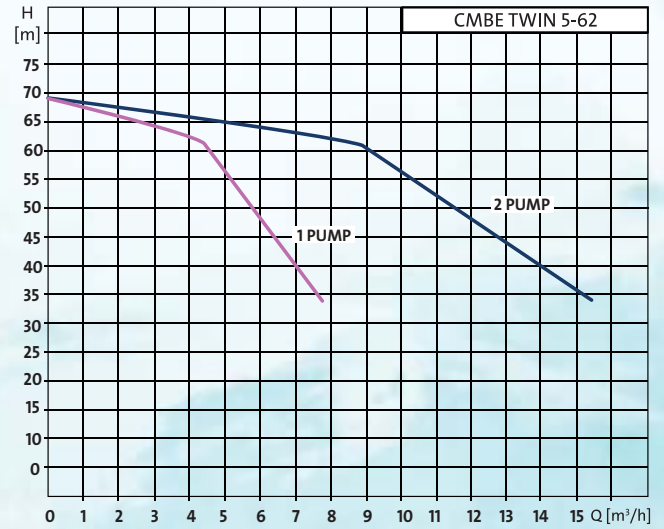
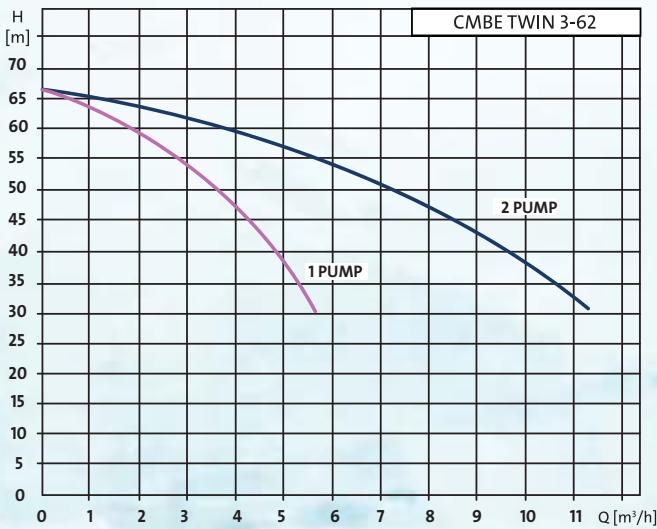

PRODUCT RANGE

Part Code	Model	Power Each Pump		Voltage	(Recommended)* Manifold Size (mm)	
		Kw	Hp		Suction	Delivery
99219420	CMBE Twin3-62	1.1	1.5	1 x 200-240	50	50
99219423	CMBE Twin 5-62	1.5	2	1 x 200-240	75	50

For all pumps, electrical supply is 1 phase 200-240 Volts AC, 50 Hz

* Manifold not part of system supply

UPA

The Grundfos UPA range is a compact domestic pressure booster, that makes the required water pressure available at tap, showers and other tapping points in residential buildings and private homes with ease.

The new UPA range completes a full-line product offering (hot & cold water) for pressure booster.

APPLICATIONS

- Domestic boosting with inlet pressure (0.1 bar) for single shower, taps, gas heaters and washing machines
- Inlet boosting to the solar tank. Ideal for single bathroom application without special shower gadgets

FEATURES

- High comfort - very low noise
- High energy efficiency - low energy bill
- Always has the required water pressure
- Maximum reliability and robustness
- Easy installation



PERFORMANCE CURVE

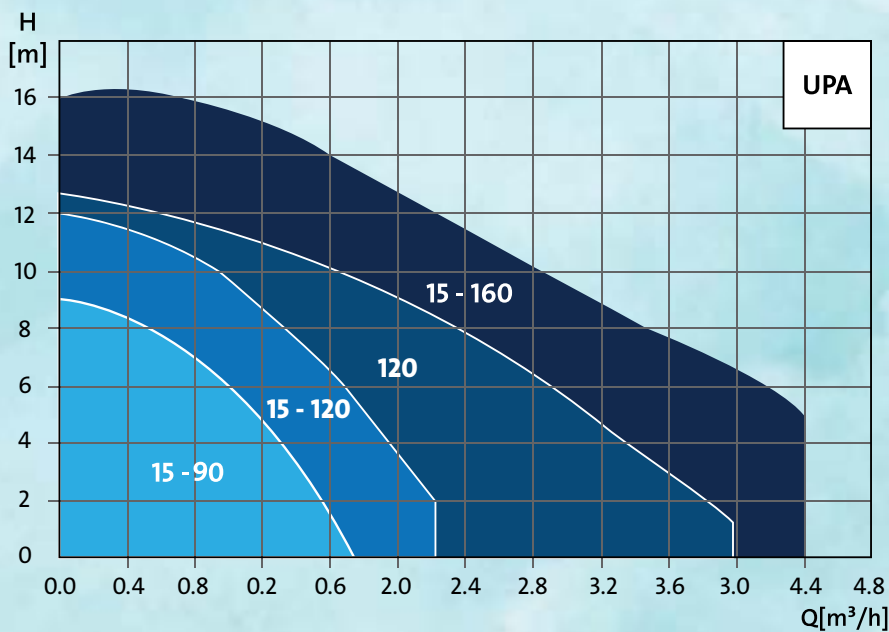

TECHNICAL DATA

MODEL	UPA15-90	UPA15-120	UPA15-160	UPA 120	Flow Switch for UPA 120
NEW PN	99539049	On Request	99331335	99553567	91760166
Head max. (m)	9	12	16	12	
Flow max. (m ³ /h)	1.8	2.2	4.4	4	
System Pressure Rating (bar)	6	10	10	10	
Liquid temperature	+2 °C to +95 °C	+2 °C to +95 °C	+2 °C to +95 °C	+2 °C to +95 °C	
Power range (P1 W)	120W	200W	180W	250W	
Motor technology	Induction	Induction	ECM	Induction	
Operation mode	Manual/Auto	Auto	Auto	Manual/Auto	
Port to port (mm)	160	200	203	180	
Pump housing	Cataphoresis coated cast iron	Cataphoresis coated cast iron	Cataphoresis coated cast iron	Cataphoresis coated cast iron	
Flow switch	Integrated	Integrated	External	External	

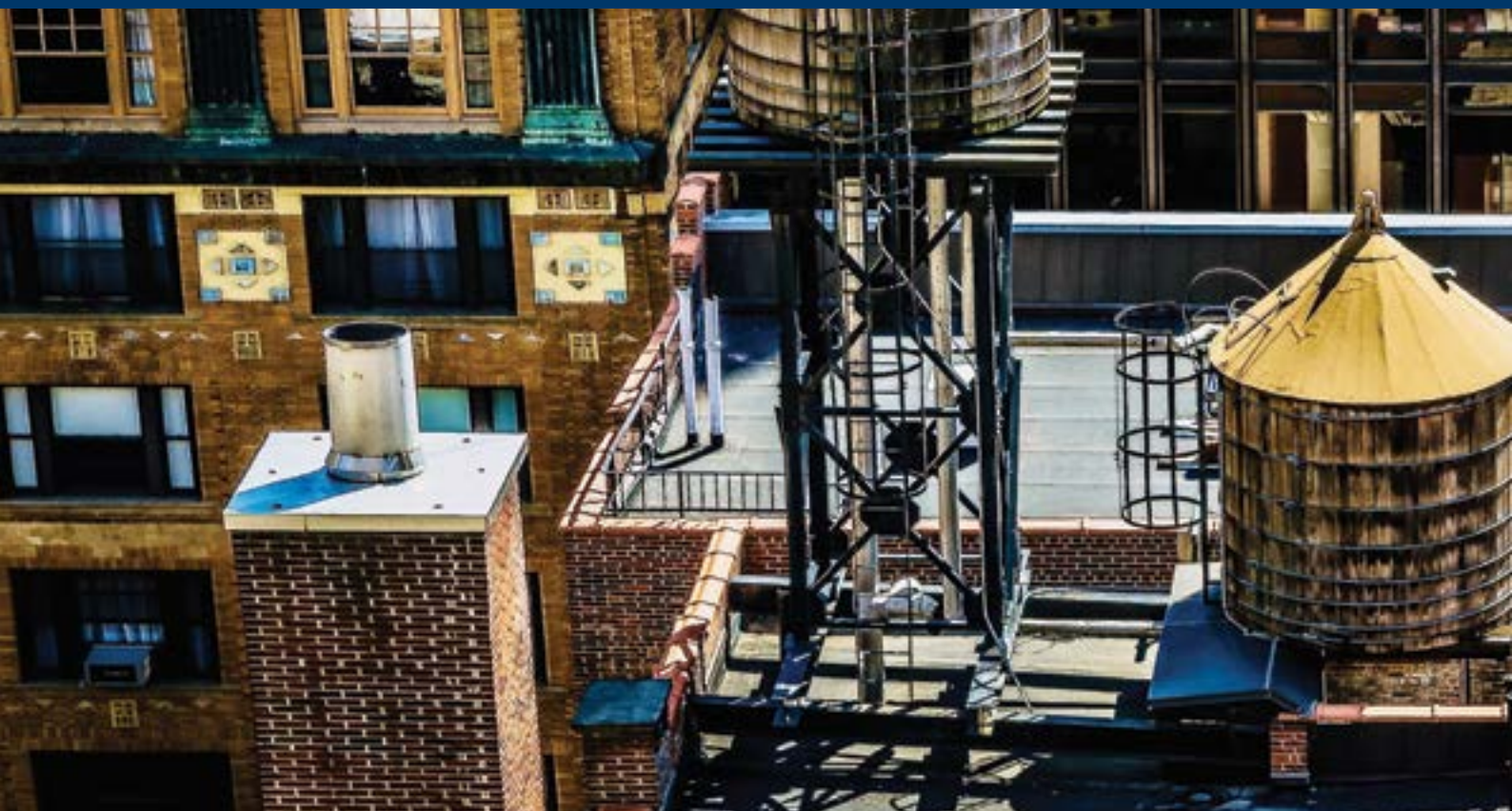



WATER TRANSFER



SmART SUB

Grundfos SmART SUB Series, Single Phase and Three Phase Horizontal open well Submersible Pumps are designed for under water application, and therefore, there is no need for priming or a foot valve.

These pumps are suitable for open wells or tanks where there are wide fluctuations in water level.

APPLICATIONS

- Sump to over head tank filling
- Farms
- Fountains
- Industrial and rural water supply
- Gardening
- Landscaping

FEATURES

- Carbon Radial bush bearing
- SS Thrust bearing and Carbon pads at both Drive End and Non-drive End to take care of axial thrust load
- PVC insulated 3 core 1.5mm motor cable
- The anti-corrosive coating on the Cast Iron parts - free from rust and corrosion
- Winding overhang protector
- Neck ring in the volute casing - High Efficiency
- Locally rewindable and repairable
- Supplied with Starter Box for 1 phase Pumps
- Designed for continuous duty S1 (3 phase only)
- Supplied with L bend stainer & Cable joining kit



PUMPED LIQUID

- Clean, thin, non-aggressive, non-explosive, clear cold, fresh water without abrasives, solid particles or fibers

CONSTRUCTION

- Impeller - Noryl & Cast Iron (CED Coated)
- Shaft - SS, Pump body - SS & Thrust ring-SS
- Radial bearing - Carbon
- Mechanical seal - Ceramic vs. Graphite
- Thrust bearing - SS / Carbon
- Inlet & outlet parts - Cast Iron

PRODUCT RANGE

Part Code	Model	Phase	Power		Voltage	Pipe Size (mm)		Hydraulic Data											
			Kw	Hp		Suction	Delivery	Flow (LPH)	7200	6600	5100	3900	2400	600					
96939851	SmART SUB HOS 1 - 0.37	1	0.37	0.5	220 V	25	25	Flow (LPH)	7200	6600	5100	3900	2400	600					
								Head (Mtr)	12	14	16	18	20	21					
96939852	SmART SUB HOS 1 - 0.75	1	0.75	1	220 V	25	25	Flow (LPH)	7800	7500	6900	6000	4800	3600	2400	1200			
								Head (Mtr)	12	15	18	21	24	27	30	32			
96939853	SmART SUB HOS 2 - 0.75	1	0.75	1	220 V	50	50	Flow (LPH)	21000	18000	15000	10800	3000						
								Head (Mtr)	6	9	12	15	18						
96939854	SmART SUB HOSD 1- 1.1	1	1.1	1.5	220 V	32	25	Flow (LPH)	8400	7670	7000	6230	5280	4360	3370	1730			
96939855	SmART SUB HOTD 1 - 1.1	3			415 V			Head (Mtr)	12	16	19	22	26	29	32	36			
96939856	SmART SUB HOSD 1.5 - 1.5	1	1.5	2	220 V	40	40	Flow (LPH)	11260	11040	10020	8750	7330	6450	5300	3780	2550		
96939857	SmART SUB HOTD 1.5 - 1.5	3			415 V			Head (Mtr)	19	21	27	33	39	43	45	48	50		
96939858	SmART SUB HOT 1.5 - 2.2	3	2.2	3	415 V	40	40	Flow (LPH)	19860	19620	19440	17580	15600	11940	8520				
								Head (Mtr)	5	10	16	21	26	31	36				
96939859	SmART SUB HOT 2 - 3.7	3	3.7	5	415 V	50	50	Flow (LPH)	33060	32160	29340	25740	22440	18420	13500	10680	7560		
								Head (Mtr)	8	10	15	20	24	28	32	34	36		
96939860	SmART SUB HOT 2 - 5.5	3	5.5	7.5	415 V	65	50	Flow (LPH)	39780	38640	36720	33660	30840	27120	23640	19440	13320	10020	6120
								Head (Mtr)	11	15	20	25	30	35	40	45	50	52	54
96939861	SmART SUB HOT 2.5 - 5.5	3	5.5	7.5	415 V	80	65	Flow (LPH)	61020	56220	50520	46380	40860	33720	25860	18420			
								Head (Mtr)	22	24	26	29	31	33	35	37			
96939862	SmART SUB HOT 2.0 - 7.5	3	7.5	10	415 V	65	50	Flow (LPH)	42120	40280	38430	35340	32160	28740	24660	22220	13740		
								Head (Mtr)	10	15	20	25	30	35	40	45	55		
96939863	SmART SUB HOT 2.5 - 7.5	3	7.5	10	415 V	80	65	Flow (LPH)	70260	66990	61860	55620	47400	38700	22140				
								Head (Mtr)	27	29	31	33	35	37	39				

For 1 Phase Voltage is 220 V
 For 3 Phase Voltage is 415 V

JP

The Grundfos JP is a self-priming, single-stage centrifugal jet pump ideal for transferring water from wells or ground tanks.

It has an excellent suction capacity and is designed for long, trouble-free operation. The built-in ejector with guide vanes ensures optimum self-priming properties. JP is small and compact with a lifting handle that makes the pump handy and easy to carry.



APPLICATIONS

- Water transfers from tanks below and above the ground level
- For treated water transfer

FEATURES

- **Self-priming**
With a suction-lift of up to 8 metres, this pump is ideal to transfer water from a well or ground tanks. This enables the JP to serve a large variety of installations
- **Robust design**
The materials of the pump are lightweight and ensure excellent corrosion resistance
- **Thermal overload protection**
JP is effectively protected against any accidental overload by built-in thermal and current protection. This means that no additional motor protection is required

TECHNICAL DATA

- **System pressure** : 6 bar max.
- **Suction lift** : **8 m max.**
- **Liquid temperature** : 0 °C to +60 °C
- **Ambient temperature** : 55 °C max.
- **Relative air humidity** : 95% max.
- **Enclosure class** : IP44
- **Approvals and markings** : CE

PRODUCT RANGE

Part Code	Model	Power		Connections	
		Kw	Hp	INLET	OUTLET
99458803	JP 3-42	0.45	0.60	G1"	G1"
99458804	JP 4-47	0.60	0.80	G1"	G1"
99458805	JP 4-54	0.75	1.00	G1"	G1"
99458806	JP 5-48	1	1.36	G1"	G1"

PERFORMANCE CURVE

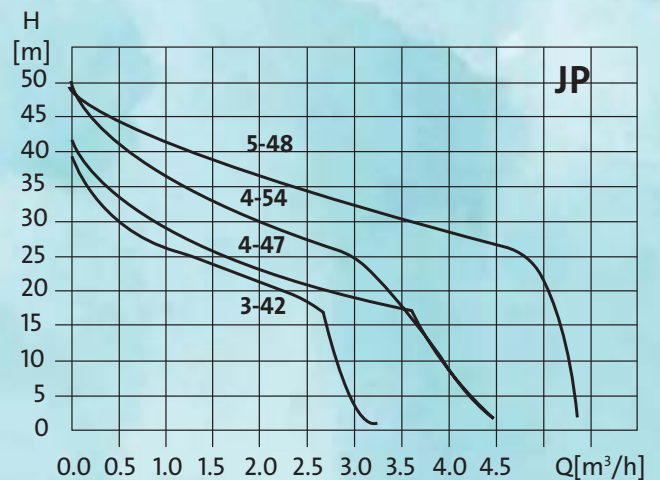

SB

The Grundfos SB pump is a submersible booster pump, designed for pumping clean water for domestic and rainwater applications. The SB pump is built of high-quality composite and stainless steel materials that are resistant to corrosion. The SB is ideal for operation in a well or ground tanks, as it easily prevents solid particles from entering the pump. The pump comes with float switch, which ensures the user a convenient experience with automatic start/stop operation and provides dry running protection. SB pumps are available with an integrated suction strainer.

APPLICATIONS

- Shallow wells
- Rainwater collection in underground tanks
- Boosting tanks

FEATURES

- **Noiseless operation**
The SB pump emits no noise when submerged and is therefore a noiseless alternative to non-submersible pumps
- **Robust design**
The SB pump is built of composite and stainless steel materials which are resistant to corrosion
- **Thermal overload protection**
Prevents accidental overload by built-in thermal protection
- **Dry running protection**
The SB pump is protected from dry running, by a float
- **Automatic operation**

PERFORMANCE CURVE

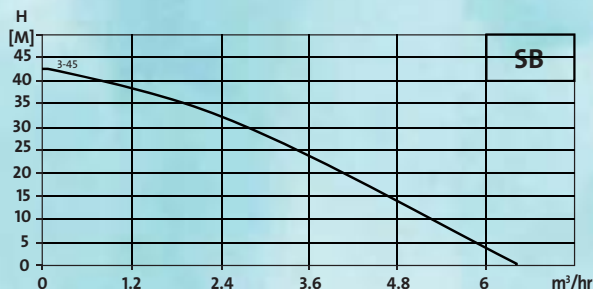

OPERATING CONDITIONS

- **Maximum particle size**
1 mm
- **Ambient temperature**
Max +50 °C
- **Liquid temperature**
0 to +40 °C
- **pH-value range**
4-9
- **Mains voltage**
1 x 220-240 V, 50 Hz
- **Insulation class**
IP68
- **Enclosure class**
B
- **Max installation depth**
10m
- **Approvals and markings**
EAC, CSA, C-tick

PRODUCT RANGE

Part Code	Model	Power		Voltage	Max Installation Depth (Mts)	Outlet Pipe Size	Weight (Kg)
		Kw	Hp				
97686705	SB3-45 A 230V 50Hz 15m	1.05	1.4	1 x 220-240	10	G 1"	9.69

For all pumps, electrical supply is 1 phase 200-240 Volts AC, 50 Hz

SP

The Grundfos SP is a 4-inch multi-stage submersible pump, designed for operation in boreholes. SP is made of corrosion resistant stainless steel, offering high operating reliability regardless of the application. The SP offers high efficiency along with high resistance to sand and other abrasive particles.

APPLICATIONS

- Water lifting from borewell
- Water transfer from ground tank

FEATURES

100% high-grade stainless steel inside and outside

As standard, all Grundfos SP pumps are made entirely of stainless steel DIN 1.4301 (AISI 304), where particularly aggressive liquids are encountered. The SP pumps are available in extra high grade stainless steel DIN 1.4401 (AISI 316), in the case of severe conditions, DIN 1.4539 (AISI 904 L) providing maximum reliability

Bearings with sand channels

All bearings are water-lubricated and are squared shape, enabling sand particles, if any, to leave the pump together with the pumped liquid

Inlet strainer

The pump is mounted with an inlet strainer preventing particles over a certain size from entering the pump

Non-return valve

SP pumps have a built-in non-return valve preventing back-flow in connection with pump stoppage

TECHNICAL DATA

- **Liquid temperature** : 0 °C to 40 °C
- **Mains voltage** : 1 x 240 V, 50 Hz
- **Enclosure class** : IP68
- **Insulation class** : F
- **Approvals and markings**: UL, CSA, VDE, CE



PRODUCT RANGE

Part Number	Description	Kw	Hp	Phase	Pump Outlet
98339969	SP 2A-28	1.5	2	1	1¼"
98574797	SP 2A-40	2.2	3	1	1¼"
96946312	SP 3A-33	2.2	3	1	1¼"
96946306	SP 3A-12	0.75	1	1	1¼"
97921288	SP 3A-18	1.1	1.5	1	1¼"
98148199	SP 3A-25	1.5	2	1	1¼"
98178763	SP 5A-8	0.75	1	1	1½"

PERFORMANCE CURVE

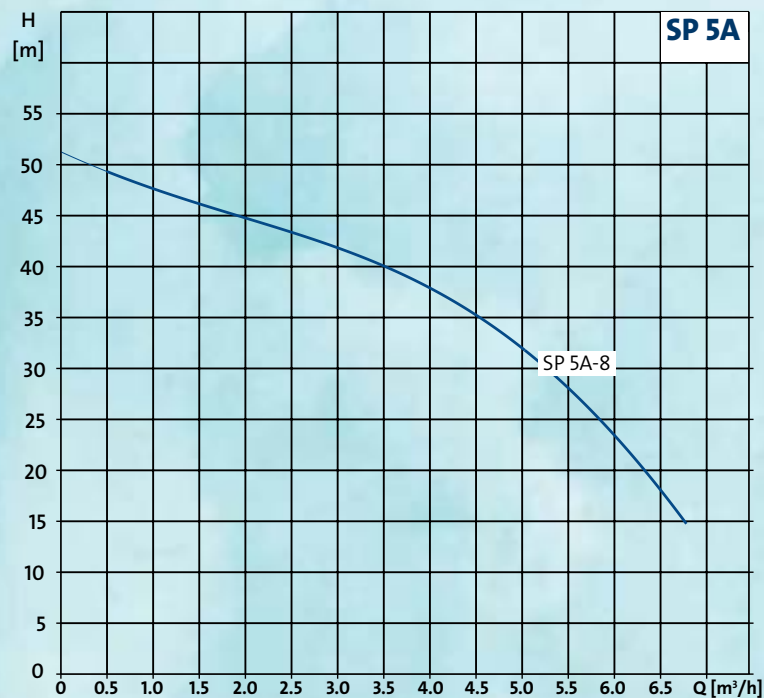
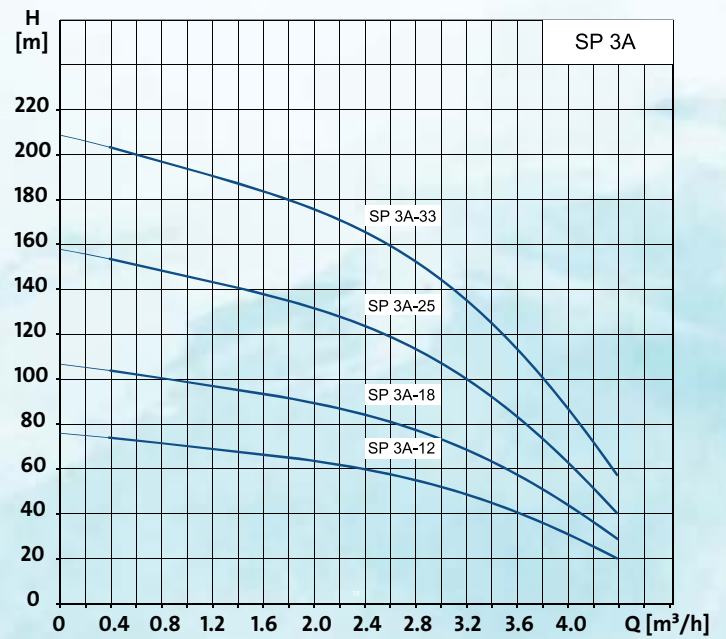
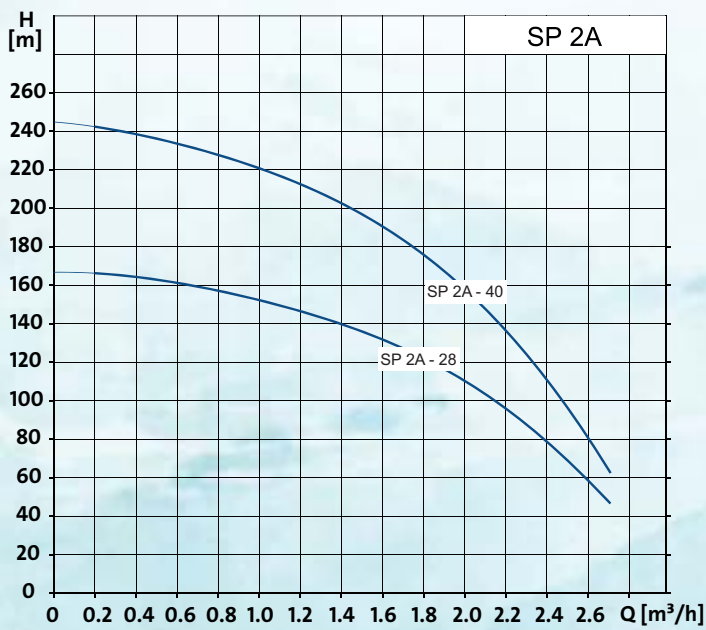

SQE

The Grundfos SQE is a small and compact submersible multi-stage pump. The motor of the SQE pump is a permanent magnet motor with a micro frequency converter ensuring optimum efficiency. The built-in frequency converter features protective functions and soft-starting, which reduces starting current and gives smooth and steady acceleration and dry running protection. The SQE pump is handy and user-friendly due to its low weight and 3-inch diameter.

APPLICATIONS

- Water lifting from borewell
- Water transfer from ground tank
- Submersible booster through external controller (CU301) from underground tanks and roof tanks

FEATURES

- **Excellent starting capabilities**
The soft starter minimises the risk of wear & tear on the pump and prevents overloading of the mains during start-up. Its soft start system also reduces water hammering, light flickering and other electrical disturbances
- **Over-voltage and under-voltage protection**
The integrated protection prevents damage to the motor, in case the supply voltage moves outside the permissible voltage range
- **Overload protection**
The SQE eliminates the need for external motor protection. If the pump is exposed to a heavy load the motor will automatically reduce its speed, or if the pump is blocked it automatically stops
- **Over-heating protection**
As an extra protection, the electronic unit has a built-in temperature sensor. When the temperature exceeds a critical limit, the pump is stopped and when the temperature has dropped, the pump automatically starts
- **Protection against up-thrust**
The SQE is fitted with an up-thrust bearing, protecting both pump and motor against up-thrust, thus, preventing breakdown during the critical start-up phase



TECHNICAL DATA

- **Liquid temperature** : 0 °C to 35 °C
- **Enclosure class** : IP68
- **Insulation class** : F
- **Installation depth** : Max. 150 m below static water level
- **Pump diameter** : 74 mm
- **Approvals and markings** : CE, UL, cUL-

PRODUCT RANGE

Part Code	Model	Power	
		Kw	Hp
96510071	SQE 1-35	0.7	0.95
96510141	SQE 1-50	0.7	0.95
96510142	SQE 1-65	0.7	0.95
96510143	SQE 1-80	1.15	1.56
96510144	SQE 1-95	1.15	1.56
96510145	SQE 1-110	1.15	1.56
96510146	SQE 1-125	1.55	2.11
96510147	SQE 1-140	1.55	2.11
96510148	SQE 1-155	1.85	2.52
96510150	SQE 2-35	0.7	0.95
96510151	SQE 2-55	0.7	0.95
96510152	SQE 2-70	1.15	1.56
96510153	SQE 2-85	1.15	1.56
96510154	SQE 2-100	1.55	2.11
96510155	SQE 2-115	1.85	2.52
96510156	SQE 3-30	0.7	0.95
96510157	SQE 3-40	0.7	0.95
96510158	SQE 3-55	1.15	1.56
96510159	SQE 3-65	1.15	1.56
96510160	SQE 3-80	1.55	2.11
96510161	SQE 3-95	1.55	2.11
96510162	SQE 3-105	1.85	2.52
96510163	SQE 5-15	0.7	0.95
96510164	SQE 5-25	0.7	0.95
96510165	SQE 5-35	1.15	1.56
96510166	SQE 5-50	1.55	2.11
96510167	SQE 5-60	1.55	2.11
96510168	SQE 5-70	1.85	2.52
96510169	SQE 7-15	0.7	0.95
96510170	SQE 7-30	1.15	1.56
96510171	SQE 7-40	1.55	2.11

PERFORMANCE CURVE

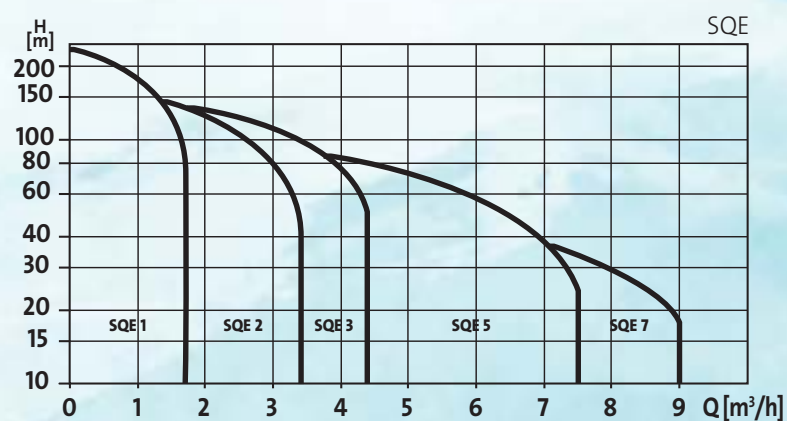





PRESSURE MANAGER



PRESSURE MANAGER- PM RANGE

PM 1 – BASIC FLEXIBILITY

The Grundfos PM1 is suitable for applications where start/stop of the pump is needed, according to the consumption. It is a solution offering the booster to start at 1.5 or 2.2 bar. PM1 starts the pump when reaching the starting pressure, and keeps running as long as there is a flow. PM1 offers dry-running protection and cycling alarm for increased safety in addition to the usual Grundfos quality, which guarantees high flexibility, robust electronics, and long life.



PM 2 – ALL-ROUND CONTROL

The Grundfos PM2 is an all-round control solution offering pressure setting range between 1.5 - 5 bar. The starting pressure is set inside the unit, whereas current pressure is read on the intuitive LED display on the front of the Pressure Manager. PM2 starts the pump when reaching the starting pressure and keeps running as long as there is a flow. PM2 is equipped with an internal pressure tank to minimise starts and stops in case of leakage in the installation. In addition, PM2 can be optimised for operation with large external pressure tank by enabling the 1 bar differential pressure functionality. This significantly reduces the number of start/stops of the pump.



PM TWIN

The all-in-one Grundfos PM TWIN is an intelligent controller, that controls two pump solutions with duty/standby mode, in accordance with consumption in domestic water supply in the range of 1.5 - 5 bar. PM TWIN is designed for automatic start/stop control of Grundfos pumps and other water supply pumps in home environment.

PM TWIN can be adapted to the individual installation through a number of DIP switches located behind the operating panel.



APPLICATIONS

• Typical applications are water supply systems and rainwater systems in:

- One-family houses
- Blocks of flats
- Villas and cottages
- Horticulture and gardening
- Agriculture

FEATURES

User-friendly interface

PM Range has a user-friendly interface with LED indicators showing:

- Power on
- Pumps running
- Alarm indication

Flexible power supply

Due to robust electronic components, PM Range can be powered by a generator or other alternative power supplies

Protective functions

PM TWIN incorporates a number of functions which protect both the pumps and the installation:

- Dry-running protection
- Cycling alarm
- Maximum continuous operating time (30 min) except PM1
- Auto-reset function which can be used to automatically restart the system in case of dry running, except PM1

Internal pressure tank

PM TWIN is equipped with a small internal pressure tank, which minimises the number of starts and stops of the pump in case of minor leakages

Overview of features

Features	PM1	PM2	PM TWIN
Power-on indication	●	●	●
Pump running indication	●	●	●
Alarm indication	●	●	●
Dry-running protection	●	●	●
Free position in installation	●	●	●
Suitable for generator supply	●	●	●
Flexible outlet connection	●	●	●
Integrated non-return valve	●	●	●
Cycling alarm	●	●	●
Integrated pressure sensor from GrundfosDirect Sensors™		●	●
Adjustable start pressure		●	●
Start/stop with 1 bar differential pressure		●	●
Automatic restarting after dry running		●	●
Maximum continuous operating time (30 min) (safety)		●	●
Internal pressure tank		●	●
Pressure indication		●	
Duty/standby twin operation			●

PRODUCT RANGE

Part Number	Model	Voltage	Start Pressure [bar]	Max Temperature		Pipe Size (inch)	
				Liquid	Ambient	Inlet	Outlet
On Request	PM 1	1 x 230 V	1.5	60 °C	55 °C	G1"	G1"
On Request		1 x 230 V	2.2	60 °C	55 °C	G1"	G1"
96848738	PM 2	1 x 230 V	1.5 - 5	60 °C	55 °C	G1"	G1"
99370355	PM TWIN	1 x 230 V	1.25 - 5	60 °C	55 °C	G1"	G1"

For all pumps, electrical supply is 1 phase 230 Volts AC, 50 Hz

PRESSURE TANK (GT)

The GT pressure tanks for cold-water applications are long life tanks for both domestic and industrial applications. The GT tank ensures controlled pressure in your water supply. The result of this is better comfort in your installation by limiting the start/stop frequency of your pump, compensation for pressure drops and eliminating water hammer in pipework. GT tanks can be integrated in many different installations with a wide variety of pumps.



FEATURES

- **Wide range of GT tanks**
The GT tanks are available in sizes from 8 to 5,000 litres, suitable for vertical installation
- **Approved for drinking water**
The Grundfos GT tanks are approved for use with drinking water
- **Reducing start/stop frequency**
The GT tanks ensure controlled pressure in the water supply and thereby limit the switching frequency of the pump in case of low water consumption or leakage loss
- **Optimise comfort**
The GT tanks increase system comfort by compensating for pressure drops when a tap is opened and reduces problems with water hammer in the pipe line

TECHNICAL DATA

- **Max. operating pressure:** Max. 10 bar
- **Liquid temperature :** Max. 90 °C
- Tank pre-charge recommended is 10% below cut in pressure for PT systems; 70% of maximum pump pressure on PM1 and PM2 units and 70% of set point on variable speed pumps
- **Approvals and markings :** CE, GOST, NSF, WRAS, ACS

PERFORMANCE CURVE

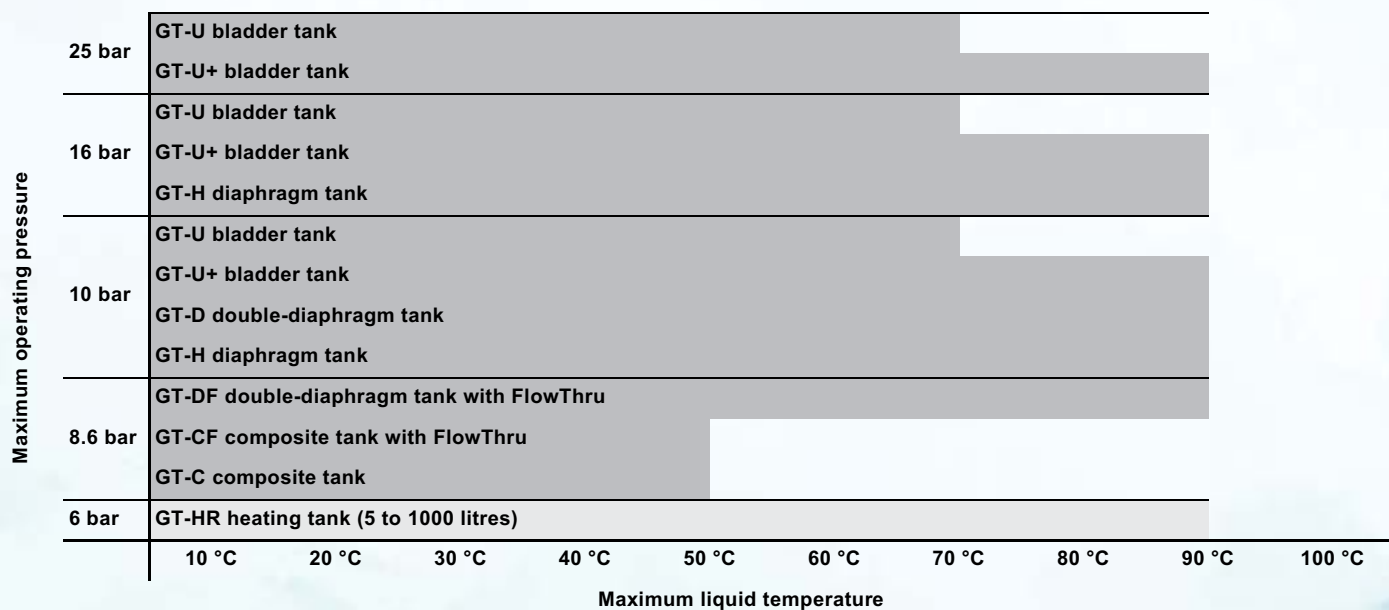

PRODUCT RANGE

Part Code	Model	Capacity	Connec- tion Size
96528339	GT-H-24 PN10 G1 V	24	1" M
96528341	GT-H-60 PN10 G1 V	60	1" F
97527968	GT-H-100 PN10 G1 V	100	1" F
97792897	GT-D-200 PN10 G1 1/4 V	200	1 1/4" F

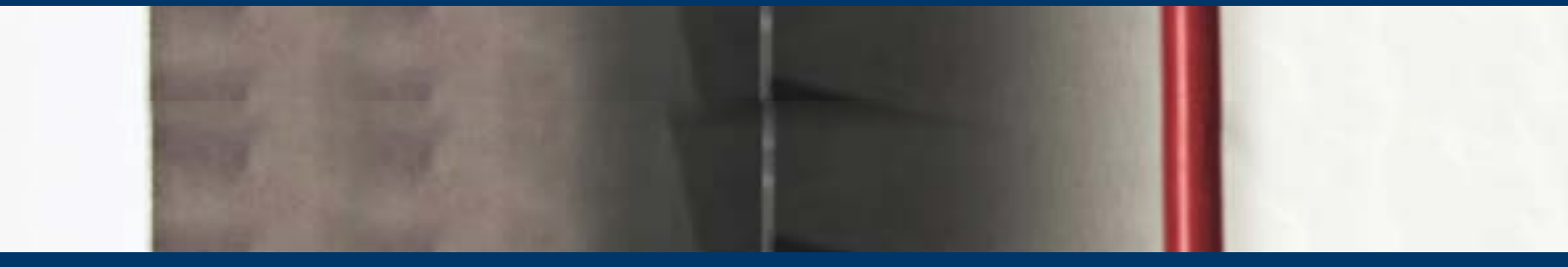



CIRCULATION PUMPS

COMFORT UP

The Grundfos COMFORT range is designed for re-circulation of domestic hot water in small family houses. The COMFORT PM range is a high efficiency choice with an energy usage of only 8 W. The intelligent COMFORT AUTOADAPT PM automatically adapts to the individual's hot water consumption pattern in the household and only runs when hot water is needed.



KEY FEATURES

Minimise water waste

Every year, a typical family of three living in a household with a conventional one string plumbing system, pours up to 16.000 Lts of clean water straight down the drain as they wait for the water to run hot. The COMFORT PM pump delivers instantly hot water, which in average amounts to 60 seconds – or 0.15 litres of wasted water per second. The tangible result of the COMFORT PM pump lowers cost while increasing the comfort

AUTOADAPT mode

The COMFORT pump learns from the user pattern and automatically adapts to guarantee the best comfort and the highest energy savings.

Temperature control mode: The water temperature is kept within a calculated range in the individual system, ensuring that the pump runs only when required to save energy

100% mode

The pump operates continuously at full speed

TECHNICAL DATA

- **System pressure** : 10 bar
- **Liquid temperature** : 2 to 110 °C
- **Ambient temperature** : 40 °C
- **Relative air humidity** : 95%
- **Mains voltage** : 1 x 240 V, 50 Hz
- **Enclosure class** : IP44
- **Insulation class** : F
- **Sound pressure level** : 43 dB
- **Approvals and markings**: AS4020

PERFORMANCE CURVE

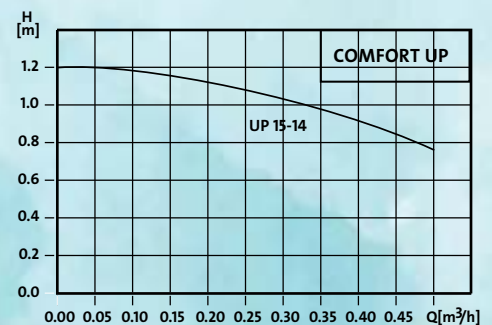

PRODUCT RANGE

Part Code	Model	Connection Size
97916757	UP15-14BA PM	½" F

MAGNA3

TAKING PUMP INTELLIGENCE TO THE NEXT LEVEL

The Grundfos MAGNA3 is a circulator pump with permanent magnet motor that will fit both heating, cooling and domestic hot water circulation, making it the obvious choice for almost any building project old or new. With its unrivalled efficiency, all-encompassing range and built-in communication capabilities plus functionalities replacing system components, the MAGNA3 is ideal for building owners, engineers and specifiers looking to create high-performance systems for buildings. The MAGNA3 is a pump with no maintenance requirements and with extremely low Life Cycle Cost.

APPLICATIONS

- Heating
- Air-conditioning
- Cooling
- Domestic hot-water systems
- Domestic heat pump

FEATURES

- **Best efficiency**
The best EEI in the market. It reduce energy cost up to 75%
- **High intelligence**
The new FLOWLIMIT and FLOWADAPT functions along with the renowned AUTOADAPT enable complete system control
- **Easy installation**
Intuitive user interface saves time during installation
- **Versatile application**
The pump handles liquids from -10 °C to 110 °C independent of the ambient temperature, to make it suitable for both heating and cooling projects
- **BMS system**
Easy integration for building management systems



PERFORMANCE CURVE

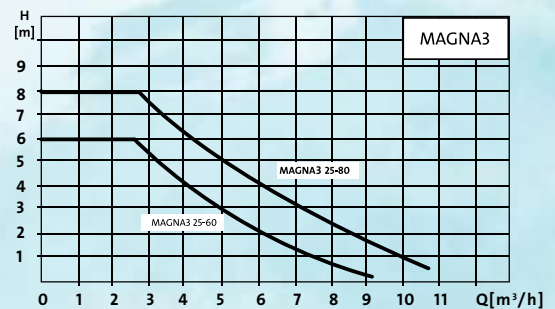

PRODUCT RANGE

Part Code	Model	Voltage	WATT	Max Liquid Temperature	Pipe size (inch)		Weight (kg)
					Inlet	Outlet	
97924245	MAGNA3 25-60	1 X 230	84	110 °C	1 ½	1 ½	4.81
97924246	MAGNA3 25-80	1 X 230	116	110 °C	1 ½	1 ½	4.81

CM

A SMALL PUMP WITH GIGANTIC POTENTIAL

It was once said that great things come in small packages. When you meet the Grundfos CM pump for the first time, you'll certainly agree. This horizontal multi-stage pump has been created with compactness and modularity as two of its central features. Adding reliability and quiet operation to the mix, another innovative pump solution from Grundfos is born.

Centrifugal Modular, the pump is basically composed of a series of interchangeable modules, all of which have been designed to work together seamlessly, whatever the application is.



APPLICATIONS

- Water treatment
- Water Transfer
- Water circulation (liquid temp 20 °C - 120 °C)

FEATURES

- Compactness
- Reliability
- Flexibility

PRODUCT RANGE

Part Code	Model	Power		Flow	Hydraulic Data							Pipe Size (mm)	
		Kw	Hp	M ³ /hr	0	0.4	0.8	1.2	1.6	2	2.4	Suction	Delivery
				LPM	0	6.6	13.3	20	26.6	33.3	40		
96935383	CM 1-2	0.3	0.4	Head (Mts)	18	17	16	14.5	12.5	10	7	25	25
96806792	CM 1-3	0.3	0.4		27	26	24	21	18	14.5	10.5	25	25
96935390	CM 1-4	0.5	0.7		36	34.5	32	28.5	24.5	19.5	14	25	25
96806794	CM 1-5	0.5	0.7		44.5	43	39.5	35	30	24	17	25	25
96935407	CM 1-6	0.5	0.7		53.5	51	47	42	35	28	20	25	25
Part Code	Model	Power		M ³ /hr	0	0.8	1.6	2	2.4	3.2	4	Suction	Delivery
		Kw	Hp	LPM	0	13.3	26.6	33.3	40	53.3	66.6		
				96806802	CM 3-2	0.3	0.4	Head (Mts)	18.5	17.5	16.5	16	15
96806803	CM 3-3	0.5	0.7	28	26.5	25	24		23	19.5	15	25	25
96806858	CM 3-4	0.5	0.7	37	35	33	31		30	25	19	25	25
96806804	CM 3-5	0.5	0.7	46	43.5	40	38		35.5	29.5	22	25	25
96806805	CM 3-6	0.7	0.9	56	53	49	46.5		43.5	37	27	25	25
Part Code	Model	Power		M ³ /hr	0	1	2	3	4	5	6	Suction	Delivery
		Kw	Hp	LPM	0	16.6	33.3	50	66.6	83.3	100		
				96806811	CM 5-2	0.5	0.7	Head (Mts)	19	18	17	16	15
96806812	CM 5-3	0.5	0.7	28	26.5	25.5	24		22	19	15	32	25
96806833	CM 5-4	0.7	0.9	38	36	34	32		30	26	20	32	25
96806813	CM 5-5	0.9	1.2	47.5	45.5	43.5	41.5		38.5	34	26.5	32	25
96935462	CM 5-6	1.3	1.7	57.5	56	54	51		47.5	41.5	33	32	25
Part Code	Model	Power		M ³ /hr	0	3	6	8	10	12	14	Suction	Delivery
		Kw	Hp	LPM	0	50	100	133.3	166.6	200	233.3		
				96935481	CM 10-2	1.3	1.7	Head (Mts)	32.5	32	30	28	25
On request	CM 10-3	1.7	2.3	47	46	43	39.5		35	30	24	40	40

For all pumps, electrical supply is 1 phase 200-240 Volts AC, 50 Hz

UPS

The Grundfos UPS range of domestic circulator pumps are suitable for circulation of liquid in domestic heating and hot water systems. These pumps with wet-rotor circulators are whisper-quiet and maintenance-free. They feature an integrated pump and motor design. The 3-speed switch on the UPS Basic motor allows you to adjust the pump speed to meet the needs of your system, thereby reducing energy consumption and saving you money.

APPLICATIONS

- It is specially used in heating system, condenser and air-conditioning system
- Hot water system in villas and apartments
- Domestic hot water recirculation system
- Heating system

FEATURES

- Pumping liquids: Thin, clean non-corrosive, non-erosion
- Non-explosive without solid particles and fiber liquids
- Liquid Temp range - 0 °C to 109 °C
- Working Temp - 60 °C
- Pressure Rating - Upto 10 bar

PRODUCT RANGE

Part Code	Model	Dimensions						Weight (kg)
		B1	B2	H1	H2	L	G	
96281471	UPS 15-60	75	51	28	102	130	1"	2.5
99309993	UPS 25-60	73	51	32	102	180	1½"	2.6
96621354	UPS 25-70	75	51	32	102	180	1½"	2.6

All Dimensions in mm

For all pumps, electrical supply is 1 phase 230 Volts AC, 50 Hz

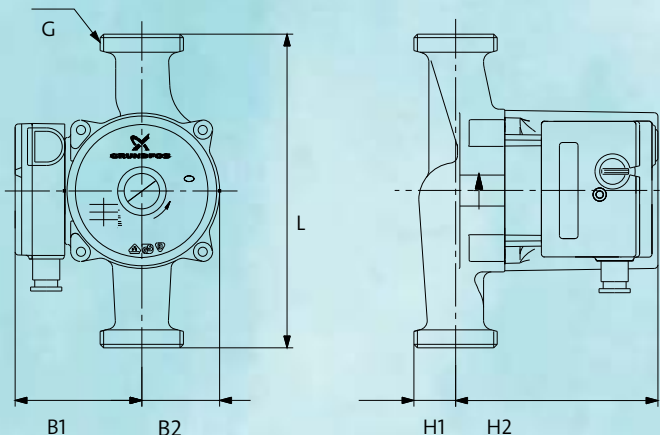

OPERATING CONDITIONS

UPS 25-60

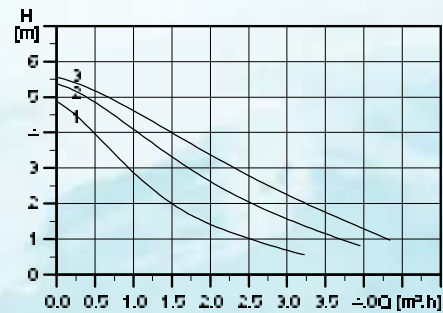

UPS 25-70

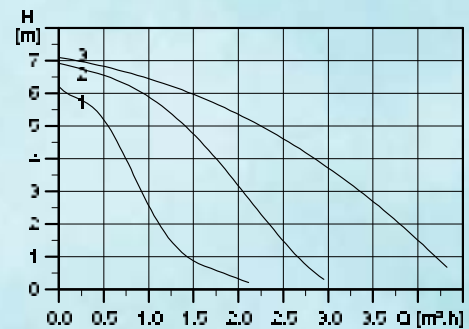

UPS 15-60

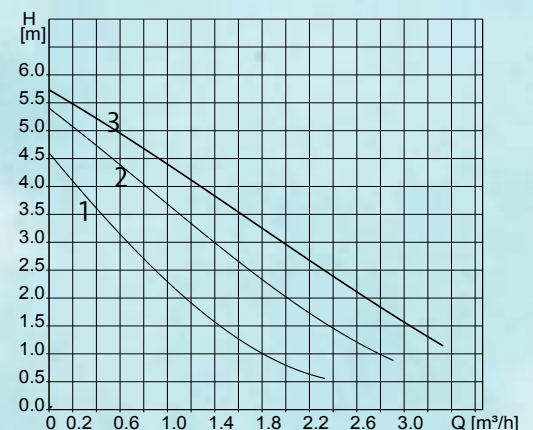

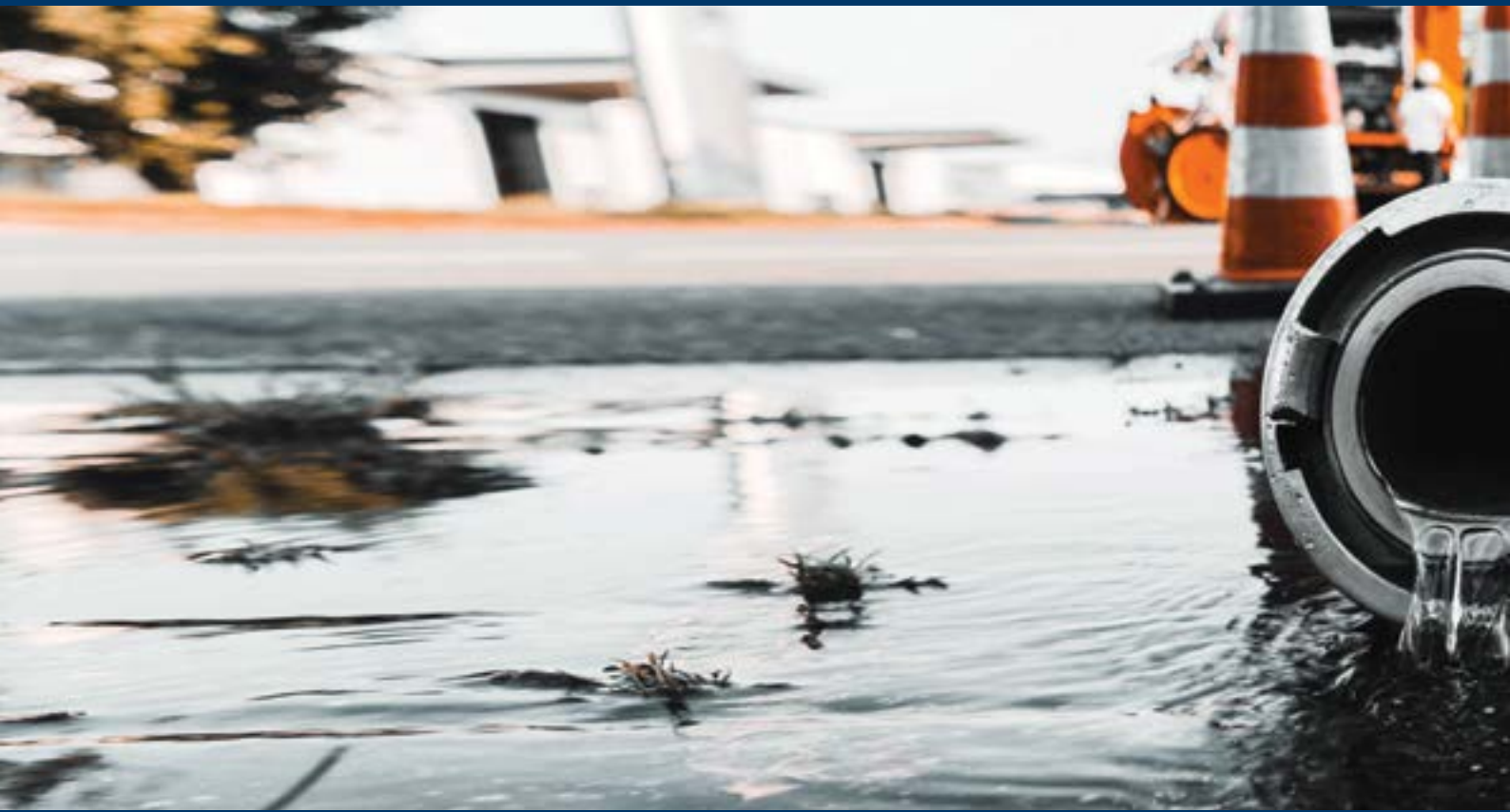



DRAINER PUMPS



KPC SERIES

SUBMERSIBLE PUMPS FOR YOUR HOME

The Grundfos KPC Series designed mainly for automatically operated fixed applications in domestic use, draining basements and garages which are subject to flooding. Its compact, easy-to-handle form makes it a portable pump for emergencies such as lifting water from tanks or emptying swimming pools, fountains, excavations and underpasses. They are also ideal for gardening and fish pond.

TECHNICAL DATA

- Pump body, impeller, pressure disc and suction grid in Composite Noryl GFN 2
Stainless steel screws and rotor shaft
- **Performance range:**
From 1 to 17m³/h , with head up to 10 metres
- **Liquid quality requirements**
Grey water without fibres
- **Minimum water depth**
KPC 24/7 210 : 8 mm
KPC 300A : 85 mm
KPC 600A : 175 mm



FEATURES

- Compact
- Reliable
- Easy to Install
- Automatic operation

KPC 24/7 210 – Fountain Pump

PERFORMANCE CURVES AND RANGE

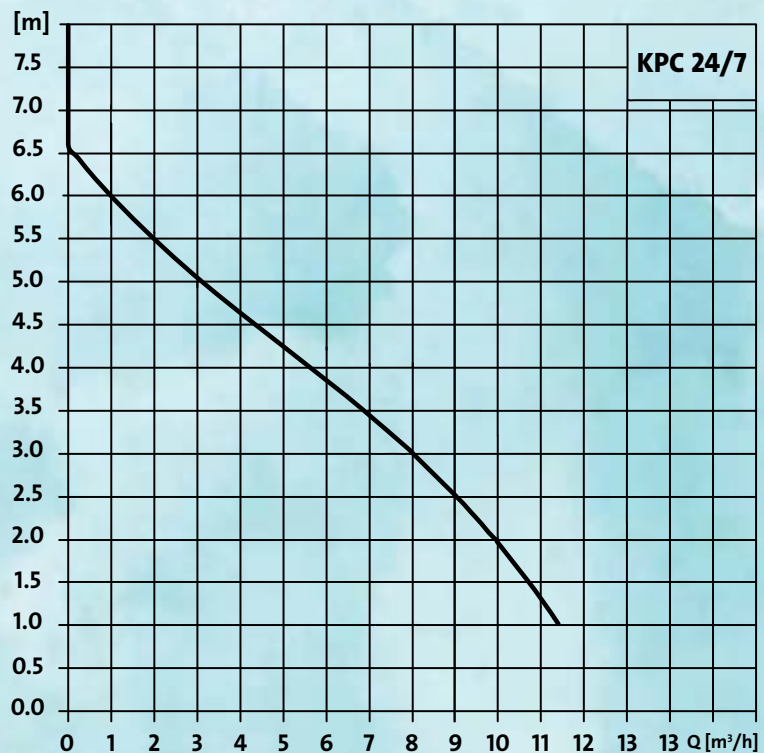
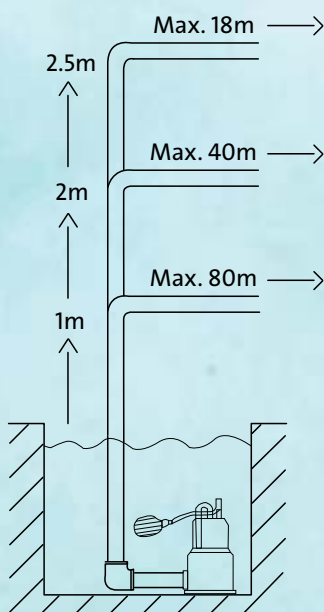

KPC 300A & KPC 600A – Dewatering Pumps

PERFORMANCE CURVES AND RANGE

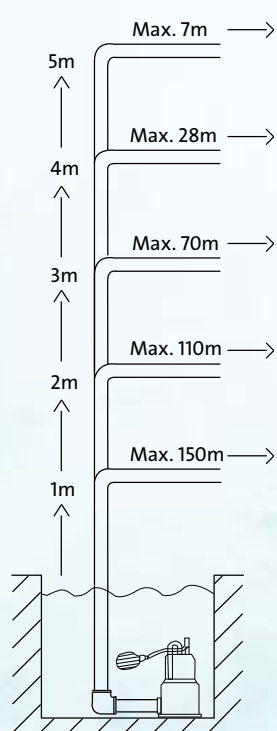

KPC 300A

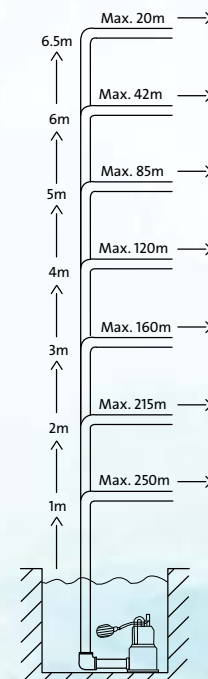
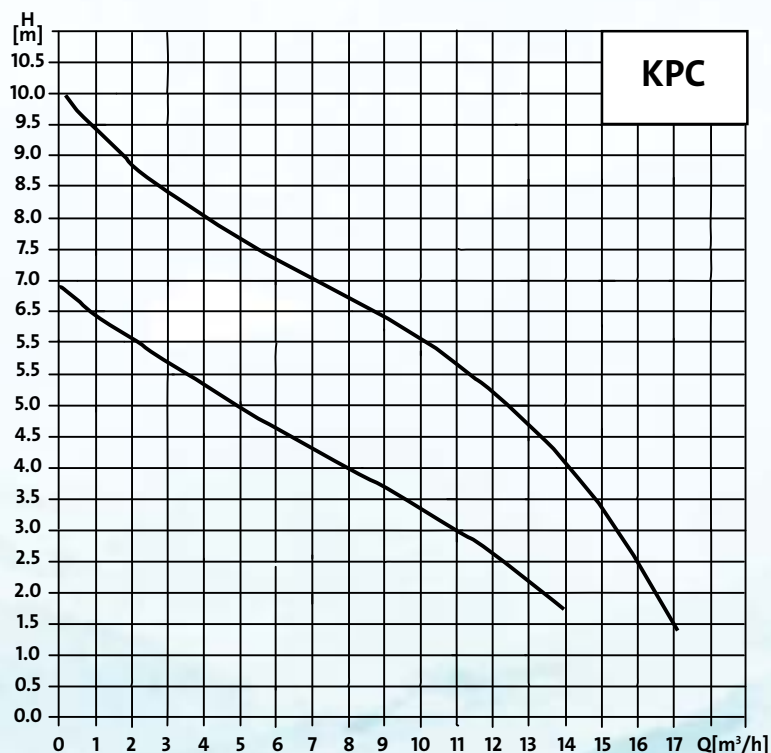

KPC 600A

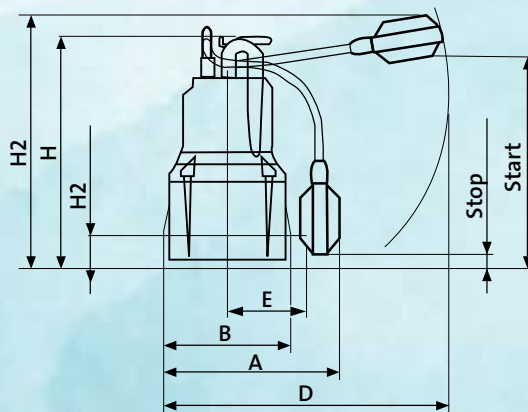

PRODUCT RANGE

Part Code	Model	Voltage (V)	Power		Current I (A)	Dimension										Weight (kg)
			kw P1	Hp		A	B	D	E	H	H1	H2	START	STOP	PIPE SIZE	
98851057	KPC 24/7 210	1 x 220V	0.35	0.47	1.5	-	140	-	82	266	-	38.5	-	-	1"	4.1
98851053	KPC 300 A	1 x 220V	0.35	0.47	1.5	185	140	225	82	275	390	47.5	350	100	1"	4.1
98851054	KPC 600 A	1 x 220V	0.8	1.07	3.4	200	160	225	90	376	490	73	450	200	1 1/4"	6.5

UNILIFT CC

The Grundfos Unilift CC pumps are single-stage submersible pumps that can pump up to 3 mm water level. The pumps are designed for pumping rainwater and grey wastewater from:

- Washing machines, bath tubs, showers, sinks from low-lying parts of the buildings up to sewer level
- Cellars or buildings prone to flooding
- Draining wells
- Collecting wells for surface water with inlets from roof gutters, tunnels
- Swimming pools, ponds or fountains. The pumps are suitable for permanent installation or as a portable pump

KEY FEATURES

- Pumping down to a level of 3 mm above floor
- Prevention of back-flow
- Thermal overload protection
- Handy and easy to transport
- Self-venting valve
- Auto-restart
- Can be connected to different outlet sizes using an adaptor

PERFORMANCE CURVE

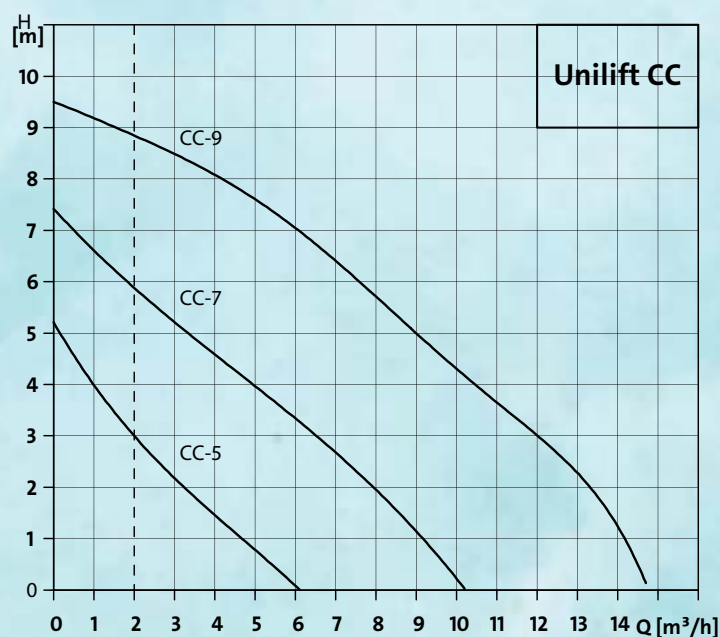

TECHNICAL DATA

- **Max. flow rate, Q** : 14 m³/h
- **Max. head, H** : 9 m
- **Liquid temp.** : 0 °C to +40 °C
- **Max. particle size** : 10 mm
- **Material** : Composite
- **Installation depth** : Max. 10 metres below liquid level

SELECTION

The overview below is suitable for the selection of the correct size of Unilift CC pumps used in stationary applications. The flow velocity through the discharge pipe must be minimum 0.7 m/s to ensure self-cleaning.

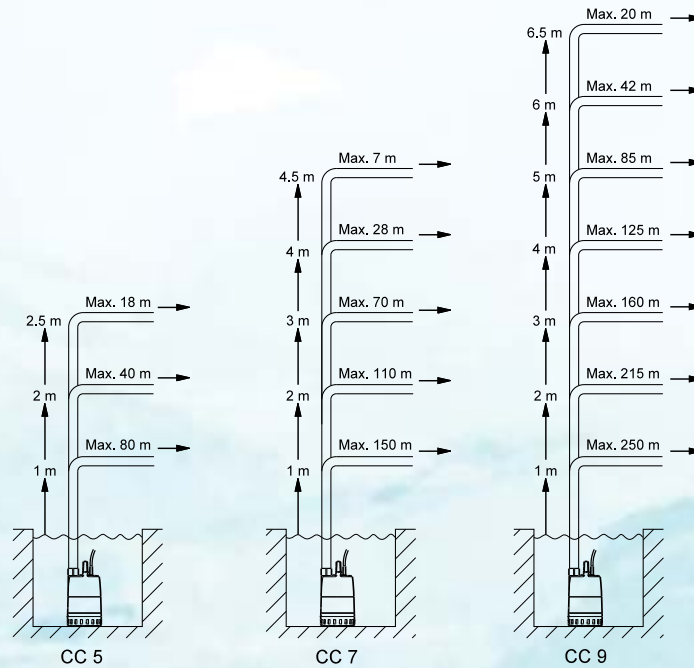

INSTALLATION

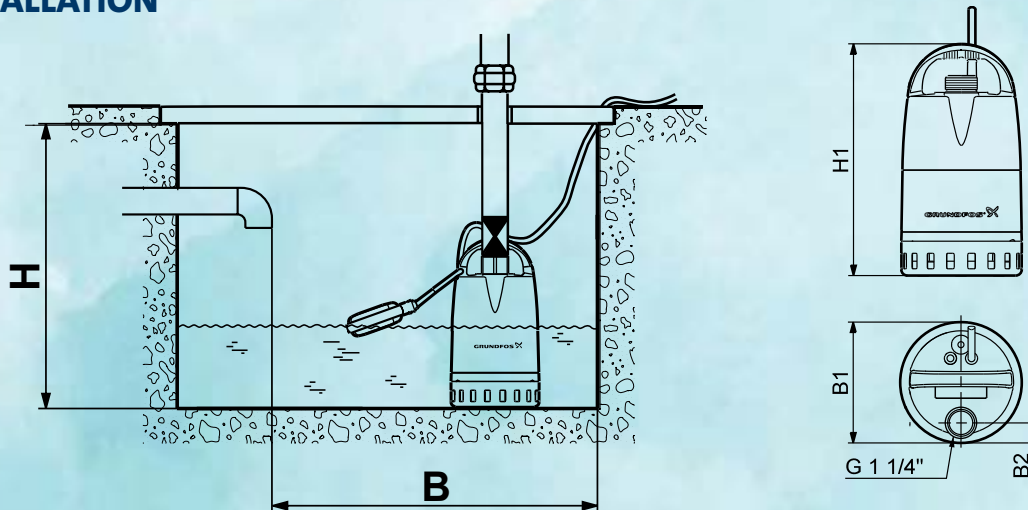

PRODUCT RANGE

Part Code	Model	Voltage (V)	Power		Current I (A)	Min Tank Size		Pump Dimension (mm)			Outlet Pipe Size	Weight (kg)
			kw P1	Hp		H	B	H1	B1	B2		
96280966	UniliftCC5-A1	1 x 220-240	0.24	0.32	1.1	520	400	305	160	26.5	1 ¼	4.35
96280968	UniliftCC7-A1	1 x 220-240	0.38	0.51	1.7	520	400	305	160	26.5	1 ¼	4.60
96280970	UniliftCC9-A1	1 x 220-240	0.78	1.05	3.7	570	500	340	160	26.5	1 ¼	6.50

UNILIFT KP

The Grundfos Unilift KP is a single-stage, stainless steel drainage pump, compact in design with hermetically sealed stator housing (canned motor). The pump can be installed permanently or used as a portable pump. It may be operated fully or partially submerged.

The pump is suitable for the following applications:

- Pumping in drainage collecting wells
- Pumping of wastewater without discharge from toilets
- Drainage of flooded cellars or buildings
- Emptying of swimming pools, tanks and fountains
- Applications within agriculture, horticulture, dairies, breweries and the process industry

KEY FEATURES

- Thermal overload protection
- Auto-restart
- Handy and easy to transport
- Clip-on strainer for easy maintenance

TECHNICAL DATA

- **Max. flow rate, Q** : 14 m³/h
- **Max. head, H** : 9 m
- **Liquid temp.** : 0 °C to +50 °C
- **Max. particle size** : 10 mm
- **Material** : Stainless steel
- **Installation depth** : Max. 10 metres below liquid level



PERFORMANCE CURVE

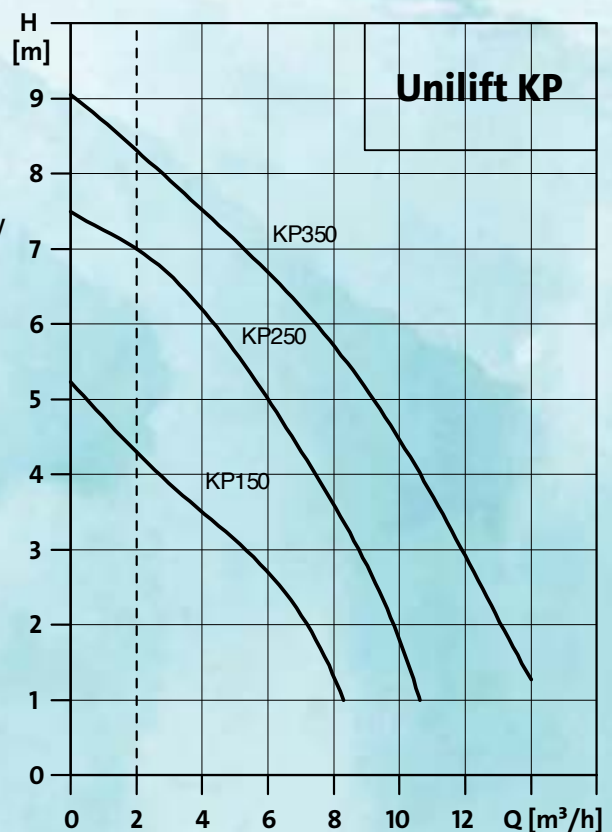

SELECTION

The overview below is suitable for the selection of the correct size of Unilift KP pumps used in stationary applications. The flow velocity through the discharge pipe must be minimum 0.7 m/s to ensure self-cleaning.

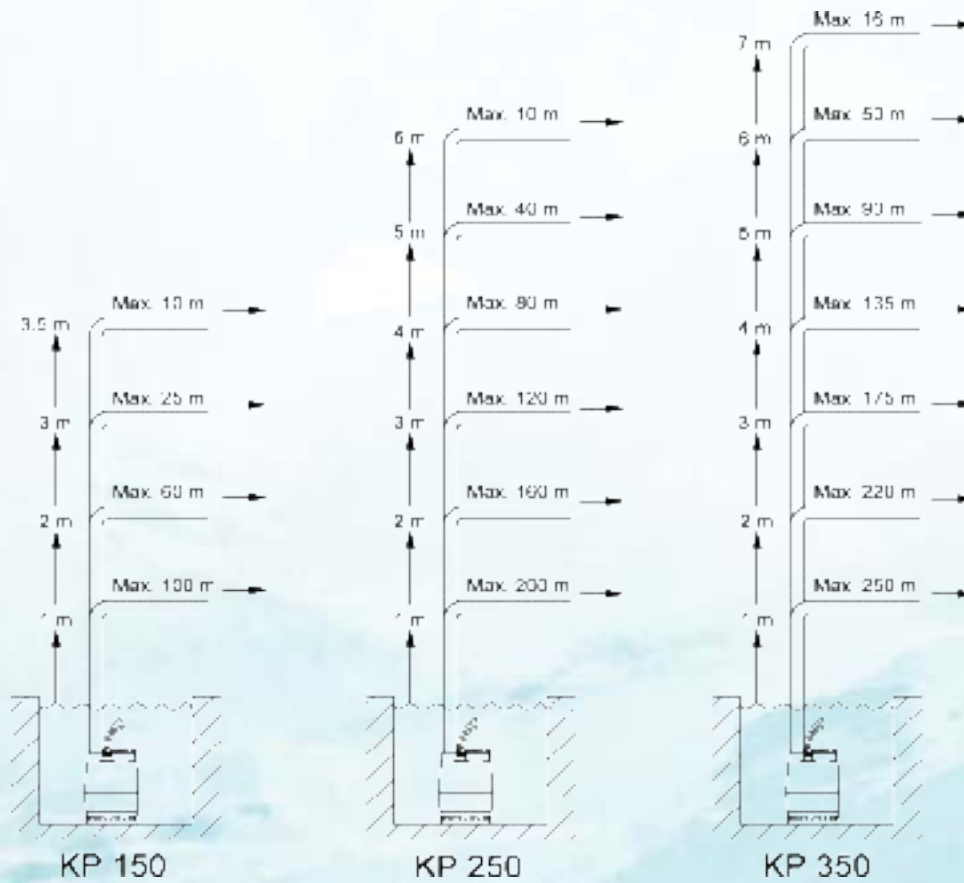

INSTALLATION

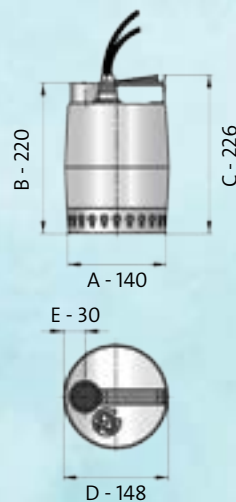
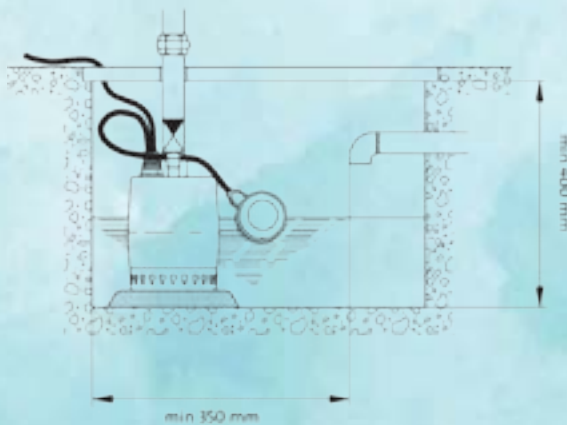

All dimensions in mm

PRODUCT RANGE

Part Code	Model	Voltage (V)	Power		Current I (A)	Pump Dimension (mm)					Outlet Pipe Size	Weight (kg)
			kw P1	Hp		A	B	C	D	E		
011K4700	Unilift KP 150 A1	1 x 220-240	0.3	0.4	1.3	140	220	226	148	30	1 1/4	7
012K4700	Unilift KP 250 A1	1 x 220-240	0.48	0.64	2.3	140	220	226	148	30	1 1/4	7
013N4700	Unilift KP 350 A1	1 x 220-240	0.7	0.94	3.2	140	220	236	148	30	1 1/4	7.3

For all pumps, electrical supply is 1 phase 200-240 Volts AC, 50 Hz

UNILIFT AP

Grundfos UNILIFT AP submersible wastewater pumps are suitable for temporary as well as permanent free-standing installation. All pumps are fitted with carrying handles. The UNILIFT AP pumps have a stainless steel sleeve for cooling during operation.

BENEFITS

- Permanent as well as portable installation
- Easy to install
- Service friendly
- Optional automatic operation

APPLICATIONS

- Rainwater, drainage water and water from flooding Pools
- Effluents from showers, washing machines and sinks below sewer level
- Water and rainwater in horticulture

FEATURES

- Stainless steel
- Mechanical shaft seal
- Replaceable cable
- High single-phase protection - no additional motor protection needed
- Semi-open or vortex impeller
- Handy and easy to transport
- Clip-on strainer prevents large particles from entering



PERFORMANCE CURVE

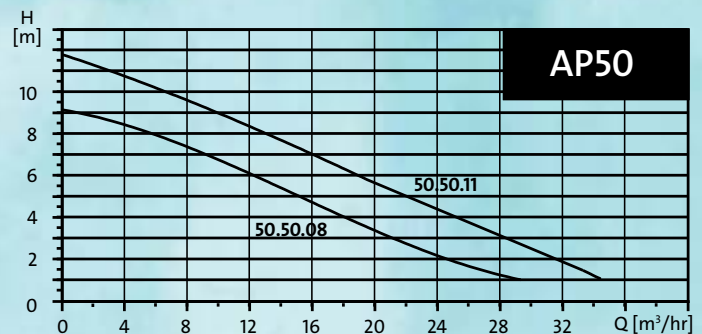
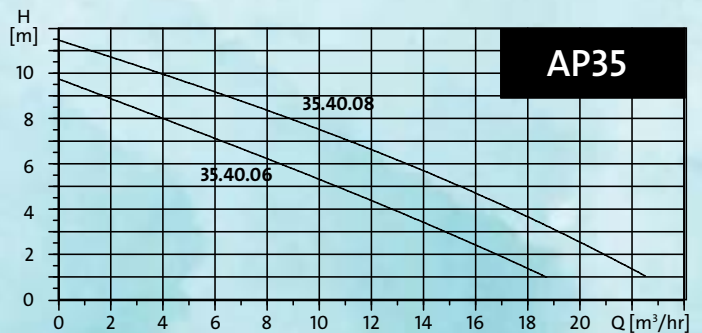
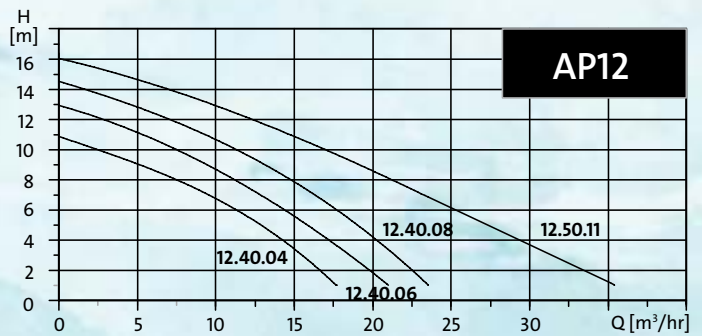

SELECTION

The overview below is suitable for the selection of the correct size of Unilift AP12 pumps used in the stationary applications. To ensure that the discharge pipe is self-cleaning, the calculation of the pipe lengths are based on these requirements.

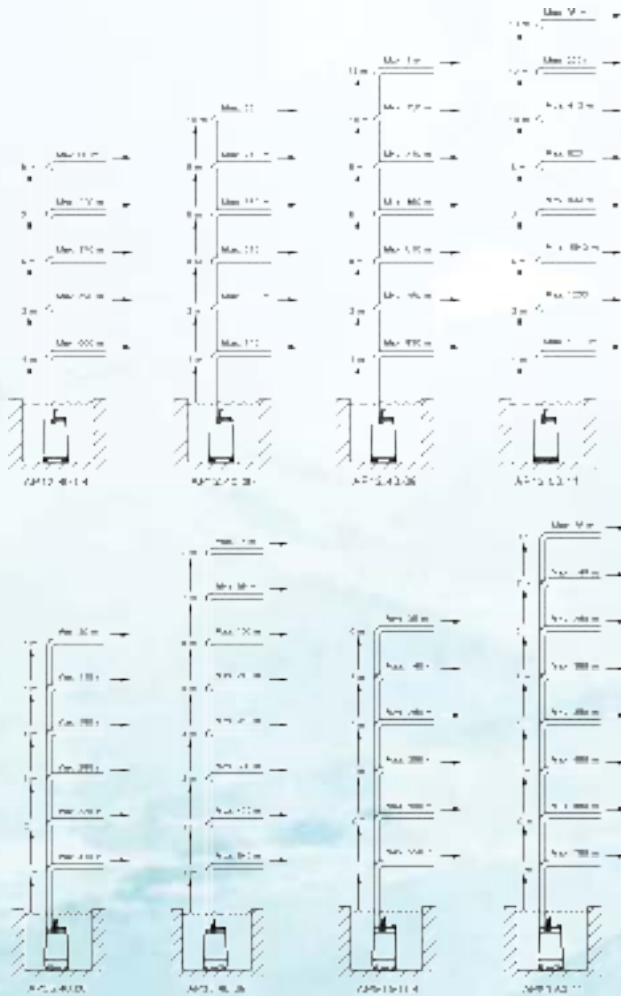

INSTALLATION

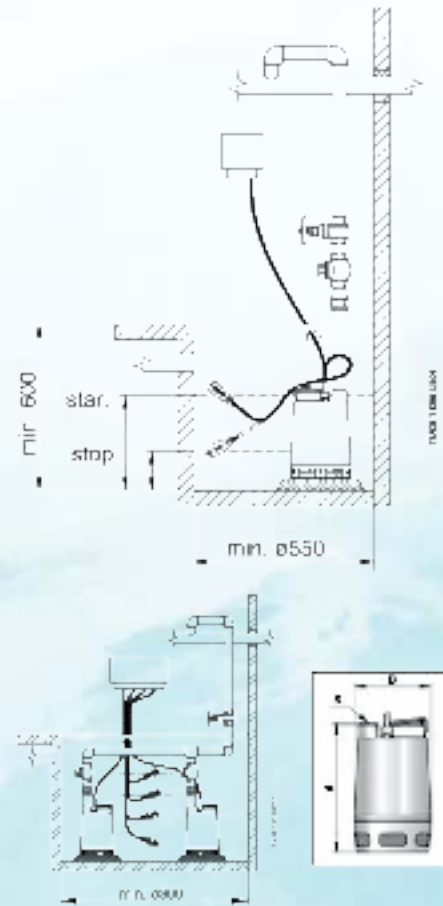

PRODUCT RANGE

Part Code	Model	Voltage (V)	Power		Current I (A)	FLOW M ³ /hr	Hydraulic Data						Solid Handling mm	Pump Dim			Weight (kg)
			kw P2	Hp			0	5	10	15	20	25		30	A	B	
96023914	AP12.40.04.A1	1 x 230	0.4	0.54	3	HEAD	11	9	7	3.5			12	321	216	RP 1½	11
96023929	AP12.40.06.A1	1 x 230	0.6	0.8	4.4		13	11	8.5	6	2		12	321	216	RP 1½	11
96023930	AP12.40.08.A1	1 x 230	0.8	1.07	5.9		14.5	13	10.5	8	4		12	346	216	RP 1½	12.6
96023931	AP12.50.11.A1	1 x 230	1.1	1.48	8.5		16	15	14	11	8.5	6	4	12	357	241	RP 2

Part Code	Model	Voltage (V)	Power		Current I (A)	FLOW M ³ /hr	Hydraulic Data						Solid Handling mm	Pump Dim			Weight (kg)	
			kw P2	Hp			0	5	10	15	20	25		30	A	B		S
96023932	AP35.40.06.A1V	1 x 230	0.6	0.8	4	HEAD	10	9	8	7	6	5	4.5	35	376	216	RP 1½	11.4
96023933	AP35.40.08.A1V	1 x 230	0.8	1.07	5.5		11.5	11	10	9	8.5	7.5	6.5	35	410	216	RP 1½	12.7

Part Code	Model	Voltage (V)	Power		Current I (A)	FLOW M ³ /hr	Hydraulic Data						Solid Handling mm	Pump Dim			Weight (kg)	
			kw P2	Hp			0	5	10	15	20	25		30	A	B		S
96023934	AP50.50.08.A1V	1 x 230	0.8	1.07	5.9	HEAD	9	8	7	5	3	2		50	436	241	RP 2	15.1
96023935	AP50.50.11.A1V	1 x 230	1.1	1.48	8		12	10.5	9	7	5.5	4	2	50	436	241	RP 2	15.1

SEG GRINDER

TOUGH WASTEWATER PUMPS

The Grundfos SEG pumps are specifically designed for pumping untreated wastewater from domestic, commercial or municipal sources. The high discharge pressure enables transfer of wastewater over longer distances. To reduce maintenance time, the effective grinder system is easily and quickly dismantled in the event of replacement.

In areas with no sewer systems or where gravitation systems are unsuitable, these pumps can transfer wastewater to the sewer mains.

BENEFITS

- Enhanced reliability
- Improved discharge pressure over longer distances
- Highly effective grinder system enables smaller pressure pipes
- SmartTrim system maintains high pressure by simple adjusting the impeller clearance
- Cable plug is sealed against the moisture entering through the cable core



Highly effective grinder: Effective cutting by a highly reliable, patented grinder



Three loose feet to be fitted to the pump housing for free-standing pumps

PERFORMANCE CURVE

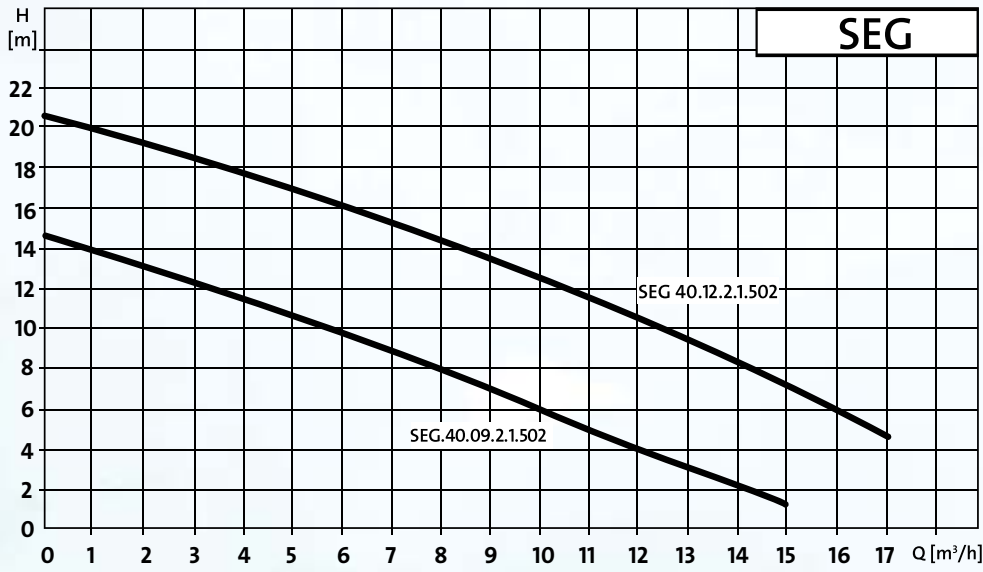

PRODUCT RANGE

Part Code	Model	Voltage (V)	Power		Current I (A)	FLOW	Hydraulic data								Flange	Outlet Pipe Size	Weight (kg)
			kw P1	Hp			0	2	4	6	8	10	12	14			
96075893	SEG.40.09.2.1.502	1 x 230	0.9	1.2	6	HEAD	14.5	13	11.5	9.5	8	6	4		DN 40	1½"	46.4
96075901	SEG.40.12.2.1.502	1 x 230	1.2	1.6	8	Mts	20.5	19	18	16	14.5	12.5	10.5	8	DN 40	1½"	42.1
96076196	Kit Feet																

For all pumps, electrical supply is 1 phase 230 Volts AC, 50 Hz





LIFTING STATIONS



SOLOLIFT2

The Grundfos SOLOLIFT2 is a unique range of compact macerators, enabling drainage of any domestic sanitary appliance without worrying about the location of the existing gravity drain system. Whether it is an extra toilet in the attic or a new bathroom below the sewer level in the basement, SOLOLIFT2 will efficiently dispose the wastewater and provide maximum protection against back-flow from sewer systems.

The SOLOLIFT2 range comprises of five compact macerators, all designed to collect and pump wastewater from the sanitary appliance to the nearest down pipe.

APPLICATIONS

- Extra bathrooms even away from drainage stack (e.g. attics)
- Backwater protection of sanitary
- Appliances when placed below the sewer level
- Added rest room and wellness facilities in guest houses and holiday cottages
- Office and building renovation

FEATURES

- **Robustness and operational reliability**
 - Powerful motors with strong starting torque for professional cutter (WC-1, -3 and CWC-3)
 - Hot water resistant components up to 90 °C for 30 minutes (C-3)
 - Pressure tight tanks withstanding up to 2.5 m water column
 - Accessories for outstanding safety like add-on alarm devices
- **Easy installation and replacement**
 - Adjustable discharge 360° turnable and for horizontal or vertical assembly
 - Flexible discharge connection with 6 different pipe diameters to connect
 - Flexible inlet connection and 4 different diameters to connect adjustable start level according to the application (C-3)
 - Including non return valve - ready to install
- **Maintenance and service friendly**
 - The removable and dry compact pump-motor unit
 - Dry and clean access to the level switch unit
 - Separate drain function of the tank



PERFORMANCE CURVE

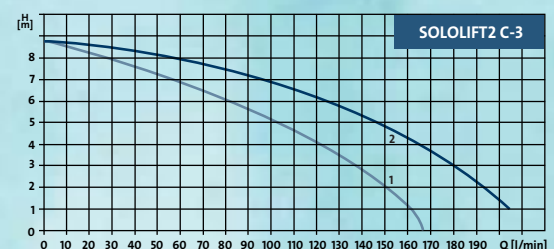
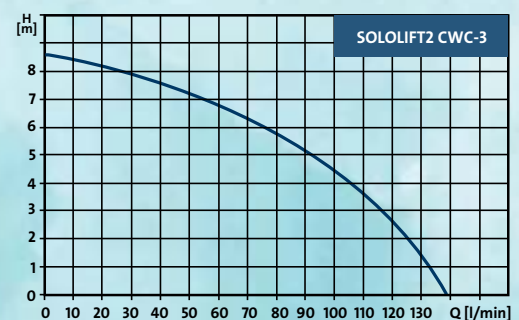
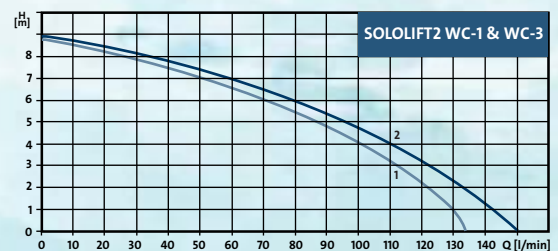

PRODUCT RANGE

Part Code	Model	Voltage (V)	Power		Dimensions (mm)		Weight (kg)
			kw	Hp	H	L	
97775314	SOLOLIFT2 WC-1	1 x 230	0.62	0.8	347	453	7.2
97775315	SOLOLIFT2 WC-3	1 x 230	0.62	0.8	347	453	7.5
97775331	SOLOLIFT2 CWC-3	1 x 230	0.62	0.8	368	495	7
97775332	SOLOLIFT2 C-3	1 x 230	0.64	0.85	255	6.5	

WC-3 key features

Suitable for pumping wastewater from:

- 1 x toilet (base stand)
- Additional sanitary appliances optional e.g:
 - 1 x washbasin
 - 1 x cabinet shower
 - 1 x a bidet or urinal

SOLOLIFT2 WC-3 for toilet, washbasin, bidet and a shower



CWC-3 key features

Suitable for pumping wastewater from:

- 1 x toilet wall hung
- Additional sanitary appliances optional e.g:
 - 1 x washbasin
 - 1 x cabinet shower
 - 1 x bidet or urinal

SOLOLIFT2 CWC-3 for wall-hung toilet, washbasin, bidet and a shower

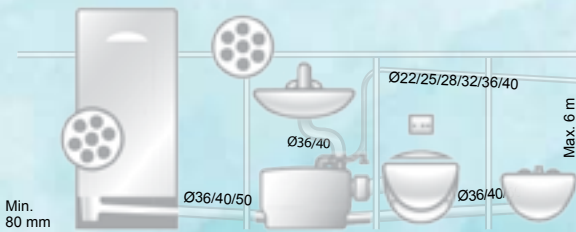

C-3 key features

Suitable for pumping grey wastewater from

- 3 different appliances in total e.g:
 - 1 x washing machine and/or dishwasher (hot water resistant up to 90°C for 30 minutes)
 - 1 x bathtub and/or cabinet shower
 - 1 x washbasin or kitchen sink
- Fits into pre-wall installations and has 20 mm free passage



WC-1 key features

Suitable for pumping wastewater from:

- 1 x toilet (base stand)
- Additional sanitary appliances optional e.g:
 - 1 x washbasin

SOLOLIFT2 WC-1 for single toilet and washbasin

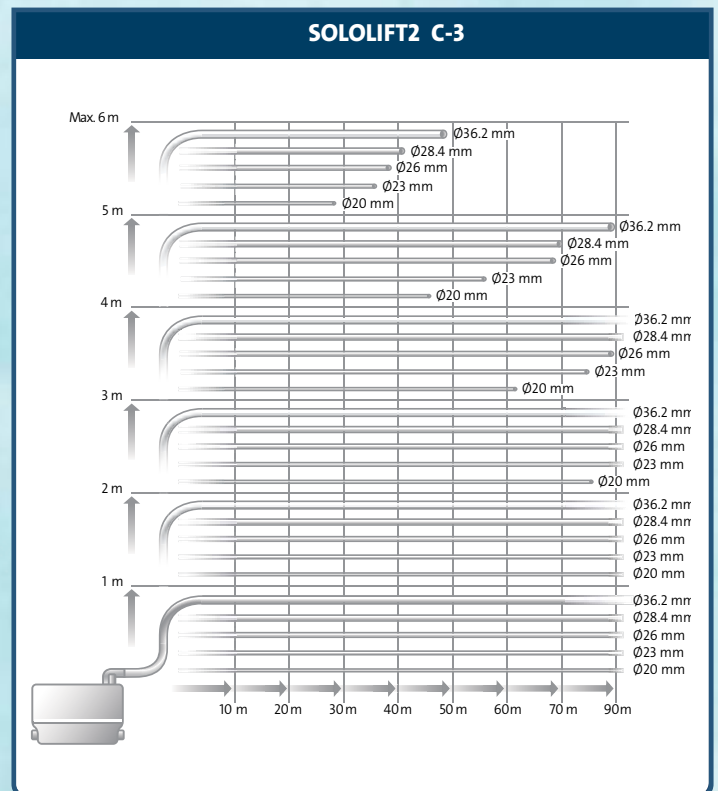
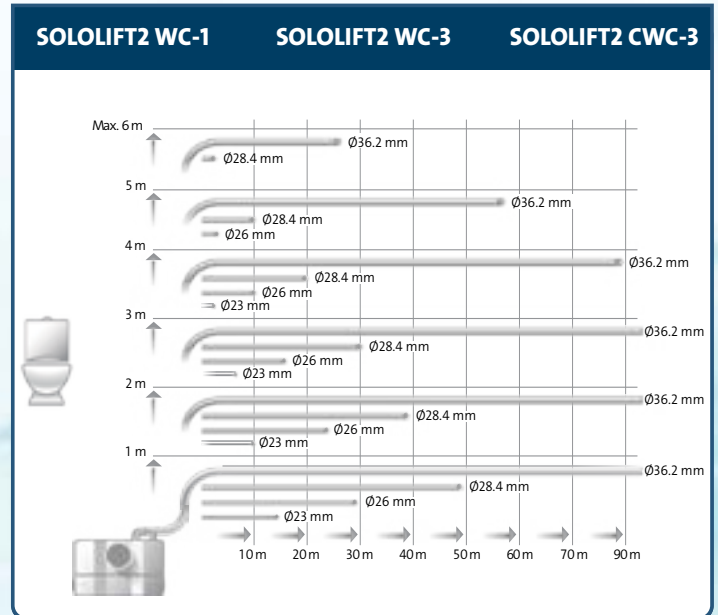
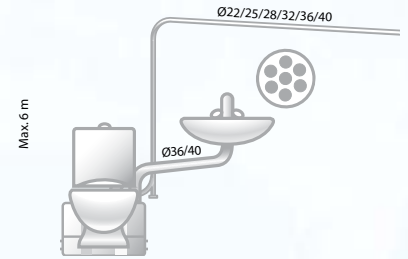

MULTILIFT MSS

The Grundfos Multilift MSS is designed to collect and transfer wastewater (with faeces) in single family houses from a complete dwelling located below sewer level where drainage by gravity is impossible.

The MULTILIFT MSS consists of a dry installed pump, collecting tank, level sensor, wired controller and a non-return valve, which are ready for installation and fully automatic, low-noise operation.

The pump is made of stainless steel and has a clog-free vortex impeller. The collecting tank is pressure tight, gas and odour proof. Together with a blockage free level sensor, the MULTILIFT MSS ensures trouble-free, reliable operation.

APPLICATIONS

- Collection and disposal of wastewater in single-family houses or light commercial applications

FEATURES

- **Easy to operate**
LC 220 controller with the setting of inlet level, safety functions and separate alarm indications for convenient operation
- **Overload protection**
Single phase motors are protected by a thermal switch in the windings and an additional thermal circuit breaker to cut out the motor in case of overload. If the motor is overloaded, it will stop automatically. When it has cooled down to normal operating temperature, it will restart automatically
- **Fast and clean service**
Servicing the dry installation pumps is easy, just empty the tank with the manual mode on the controller and dismantle the pump. The non-return valve is easily accessed for servicing
- **Flooded basements**
In a flood situation, the MSS continues to operate without problems. It is tested to withstand a flooding height of up to 2 m for one week. Pump and tank are IP68 proof



Powerful pumps

Designed for dry installation and intermittent operation, the motor can easily handle 40 starts per hour, which perfectly fits the needs of a single-family house or a light commercial application

Strong and resistant tank

The special design of the light, seamlessly moulded polyethylene (PE) tank with a wall thickness of up to 8 mm, makes the MULTILIFT tank exceptionally pressure stable (pressure proof up to a 5m water column conforming to EN12050-1)

PERFORMANCE CURVE

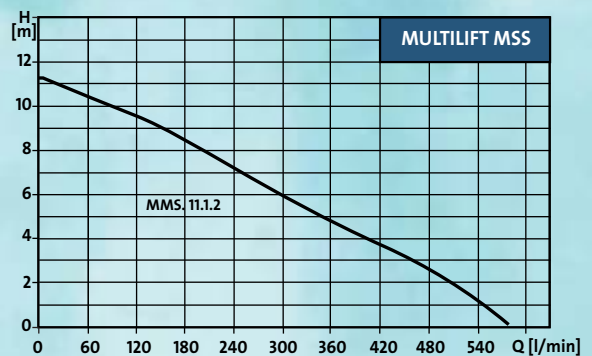

OPERATING CONDITIONS

- Liquid temperature
0 °C to +40 °C
- Ambient temperature
0 °C to +40 °C
- Relative air humidity
Max. 95%

TECHNICAL DATA

- Mains voltage
1 x 220-240 V, 50 Hz
- Enclosure class
IP68 (lifting station and motor)
IP56 (controller)
- Sound pressure level
< 70 dB (A)
- Approvals and markings
CE, LGA, VDE GROST/EAC, CB and EMW.

DIMENSIONS (mm)

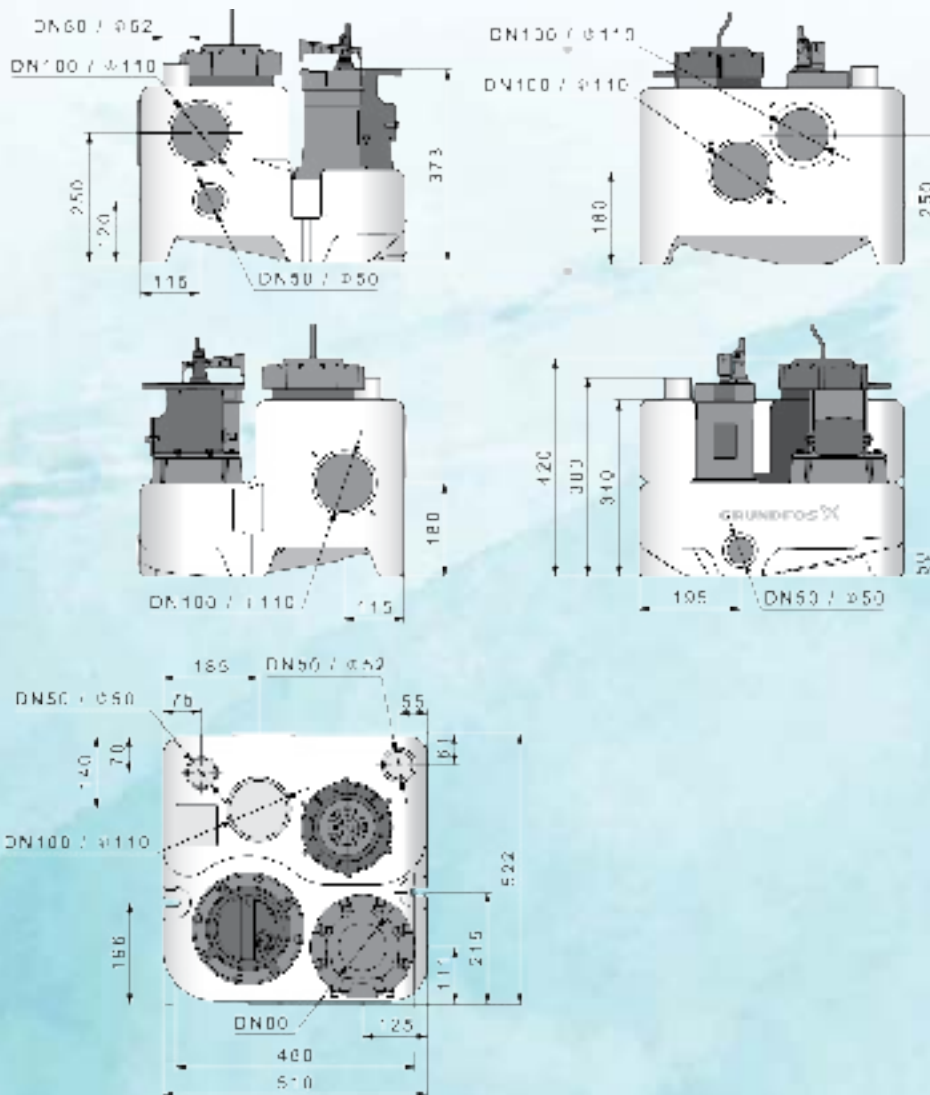

PRODUCT RANGE

Part Code	Model	Power		Voltage (V)	Current I (A)	Tank Volume			Max Particle Size (mm)
		kw	Hp			Total	At 250 mm Inlet	At 180 mm Inlet	
97901037	MSS.11.1.2	1.1	1.5	1X 230	8	44	28	20	40

For all pumps, electrical supply is 1 phase 230 Volts AC, 50 Hz





CONTROL PANELS



GIDPC DOT

GIDPC DOT is a Digital Pump Controller for domestic application, which is easy to use programmable device for single phase pumps (mono-block or submersibles which require only running capacitor). It can be used to control the pumps up to 15 A.

APPLICATIONS

- GIDPC DOT is designed and built for managing and controlling residential water i.e. the water used for indoor and outdoor household purposes, such as water transfer, tank filling, tank emptying, drainage application or pressure boosting. It is an ideal choice in residential segments, where water and energy conservation are of utmost importance

FEATURES

- LCD screen displays pump running information
- Push button calibration
- Overload protection
- Motor stalled protection
- Dry run protection without installing a float switch
- Under voltage protection (Default settings can be changed)
- Over voltage protection (Default settings can be changed)
- Transient surge protection
- Memory function retention during power off & power recovery
- Visual & audio alarm for fault prompt
- DIP switch settings to make it suitable for different applications like water supply, drainage or pressure boosting
- Auto/Manual switch
- One set (03 nos.) of liquid level probes for clear water that comes along with the panel

CONTROLLER COMPONENTS

Dip switch settings

Item	Switch Position	Messages & In Voltage Displaying Area	Item
1		000	Applied for water supply by liquid level control through probe/float switch
2		222	Applied for water supply by pressure control through pressure switch & pressure tank
3		111	Applied for drainage by liquid level control through float switch



PARAMETER AND SPECIFICATIONS:

Main Technical Characteristics	
Control characteristic	Level control (with probes for clear water or with floats) Pressure control (with pressure switch)
Working modes	Manual/Auto
Main Technical Data	
Rated output current (amperes)	1.5 to 15 A
Rated input voltage	AC 220V / 50 HZ / Single Phase
Trip response time of over load	5sec - 5min
Trip response time short circuit	Less than 0.1 sec
Trip response time of under/over voltage	Less than 5 sec
Trip response time of dry run	6 sec
Recovery time of over load	30 min
Recovery time of under/over voltage	5 min
Recovery time of dry run	30 min (or this can be set manually)
Trip voltage of over voltage	253 Volts (or this can be set manually)
Trip voltage of under voltage	175 Volts (or this can be set manually)
PROTECTIONS COVERED	Dry run (without float/probe)
	Current Overload
	Transient surge
	Under voltage
	Over voltage
	Pump stalled

CAPACITOR

- Grundfos SmART Sub/Submersible Pumps does not require the starting capacitor. It only requires the running capacitor. The ratings of the capacitors are explained in the below table

Motor Type	Rating (HP/KW)	Running Capacitor (mfd)	Capacitor Make
Gylcol+Water Filled - Tesla	0.5 / 0.37	16	EPCOS
Gylcol+Water Filled - Tesla	0.75 / 0.55	20	EPCOS
Gylcol+Water Filled - Tesla	1 / 0.75	25	EPCOS
Gylcol+Water Filled - Tesla	1.5 / 1.1	35	EPCOS
Gylcol+Water Filled - Tesla	2 / 1.5	40	EPCOS
SmART Sub HOS1/037	0.5 / 0.37	20	EPCOS
SmART Sub HOS1/075	1 / 0.75	30	EPCOS
SmART Sub HOS2/075	1 / 0.75	30	EPCOS
SmART Sub HOSD1/110	1.5 / 1.1	45	EPCOS
SmART Sub HOSD1.5/150	2 / 1.5	60	EPCOS

DRAINAGE APPLICATION BY INSTALLING FLOAT SWITCH

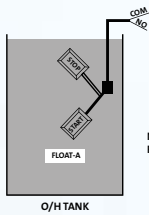

NOTE: NO CONTACT IN FLOAT DOWN POSITION

Start condition:
When the “Float switch A” reaches the up position, the controller will run the pump.

Stop condition:
When the “Float switch A” reaches the down position, the controller will stop the pump.

WORKING APPLICATIONS

Power terminals

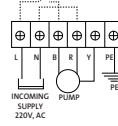

Control terminals

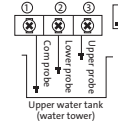

WORKING APPLICATIONS

Water supply/transfer by installing probes or Float switch

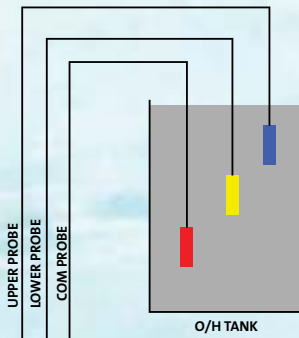

Application: Clear water supply - liquid level control (using probes)

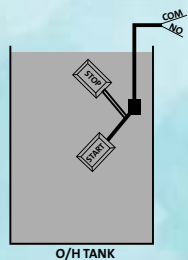

Application: Water supply - liquid level control (using float switch)

PARAMETER

Please read this manual carefully before starting the installation and operation. Any damage to the equipment caused due to failure to comply with the descriptions in this manual in installation or operation will be beyond the scope of the company's quality guarantee.

Calibration:
Setting of parameters (calibration of unit according to the connected load):

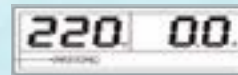

Press the **MODE** key to switch to manual mode. Make sure the pump is not running and LCD screen looks as shown on the left

1

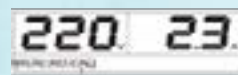

Press the **START** key to run the pump, confirm the pump is running OK and drawing rated current. Also confirm the mains supply is healthy and incoming voltage is normal, LCD screen will display voltage and current being drawn by pump

2



Again press **START** key approximately for 3 sec and release when the unit makes a “Beep” sound and a countdown timer starts on the screen. LCD screen display looks like the image on the left

3

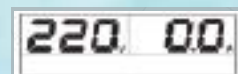

Pump stops running and parameter calibration completes. LCD screen display looks like the image on the left

4

PRODUCT RANGE

Part Code	Model	Voltage	Current I (A)	Number of Pump	Dimensions			Panel Protection	Weight [kg]
					L	W	H		
99591666	CP 1 Pump 1 Phase 15A GIDPC DOT	1 X 220	Up to 15 AMPS	1 W	160	225	100	IP 54	1.5

For all pumps, electrical supply is 1 phase 220 Volts AC, 50 Hz

GIDPC SINGLE PHASE

SINGLE PUMP, SINGLE PHASE (1.5 TO 15 A EACH)
TWO PUMPS, SINGLE PHASE (1.5 TO 15 A EACH)

GIDPC single phase is a Digital Pump Controller for domestic application, which is easy to use - programmable device for single phase pumps (mono-block or submersibles which require only running capacitor). It can be used to control the pumps up to 15 A.



FEATURES

- LCD screen displays pump running information
- Push button calibration
- Overload protection
- Motor stalled protection
- Dry run protection without installing a float switch
- Under voltage protection (Default settings can be changed)
- Over voltage protection (Default settings can be changed)
- Transient surge protection
- Memory function retention during power off & power recovery
- Visual & audio alarm for fault prompt
- DIP switch settings to make it suitable for different applications like water supply, drainage or pressure boosting
- Auto/Manual switch
- One set (03 nos.) of liquid level probes for clear water that comes along with the panel

Main Technical Characteristics

Control characteristics	Level control (with probes for clear water or with floats)
	Pressure control (with pressure switch)
Working modes	Manual/Auto
Main Technical Data	
Rated output current (amperes)	1.5 to 15 A
Rated output voltage	AC 220 V / 50 HZ / Single Phase
Trip response time of over load	5 sec - 5 min
Trip response time short circuit	Less than 0.1 sec
Trip response time of under/over voltage	Less than 5 sec
Trip response time of dry run	6 sec
Recovery time of over load	30 min
Recovery time of under/over voltage	5 min
Recovery time of dry run	30 min (or this can be set manually)
Trip voltage of over voltage	253 Volts (or this can be set manually)
Trip voltage of under voltage	175 Volts (or this can be set manually)
PROTECTIONS COVERED	Dry run (without float/probe)
	Current Overload
	Transient surge
	Under voltage
	Over voltage
Pump stalled	
Permissible ambient temperature	-5 °C to +50 °C
Degree of protection	IP 55

PRODUCT RANGE

Part Code	Model	Voltage (V)	Current I (A)	Number of Pump	Dimensions			Panel Protection	Weight [kg]
					L	W	H		
98719424	GIDPC 1 Pump, 1 Phase, 15A	1 X 220	Up to 15 AMPS	1 W	225	225	100	IP 55	1.5
99575830	GIDPC 2 Pump, 1 Phase, 15 A	1 X 220	Up to 15 AMPS	1W+1S	320	420	138	IP 55	5.5

GIDPC THREE PHASE

SINGLE PUMP, THREE PHASE (1.5 TO 16 A EACH)

TWO PUMPS, THREE PHASE (1.5 TO 16 A EACH)

The GIDPC three-phase digital pump controller model is an easy-to-use device for direct start, can be programmed, and also protects the pump. The equipment is in three-phase with output power ranging from 0.75 kW – 7.5 kW (1.5 - 16 A). The controller has many operation modes for adapting different pumping applications. Important features that distinguish the GIDPC Series Digital Pump Controllers from other controllers are the push-button calibration for overload and the ability of dry run protection without float switches.

It shows pump parameters, status, faults, etc. The controller is useful in all cases where there is a need to control and protect pump installations and manage the automatic operation by a variety of switching methods.



TYPICAL APPLICATIONS

- Storm water
- Sewage
- Booster sets
- Rainwater reuse
- Irrigation
- Water supply

FEATURES

- **Built-in function switch for:**
 - Drainage by water level control through float switches
 - Boosting water supply by pressure control through pressure switch
 - Transfer of water by water level control through float switches
- Dry run protection without float switches
- Auto/ manual switch with screen lock in AUTO mode
- Dynamic LCD displaying for pump running status
- Protect the pump against many faults
- Push button calibration
- Pump accumulative run time
- Last five fault records
- RS485 communication (Modbus)
- Starts and stops the pump in accordance with liquid levels or pressure settings
- Pump shaft is anti-rust

Main Technical Characteristics	
Control characteristic	Double liquid level control Pressure control
Working modes	Manual / auto
Drainage application	By using float switch
Pressure Boosting application	By using pressure switch
Water Transfer application	By using float switch
Main Technical Data	
Rated output power (amperes)	8 A, 12 A and 16 A
Rated input voltage	415 V / 50 Hz / 3 Phase
Trip response time of over load	5 sec - 5 min
Trip response time of open phase	< 2 sec
Trip response time short circuit	Less than 0.1 sec
Trip response time of under/over voltage	Less than 5 sec
Trip response time of dry run	6 sec (adjustable)
Recovery time of over load	30 min (adjustable)
Recovery time of under/over voltage	5 min
Recovery time of dry run	30 min (adjustable)
Trip voltage of over voltage	115 % of rated input voltage
Trip voltage of under voltage	80 % of rated input voltage
PROTECTIONS COVERED	
	Dry run (without float/ probe)
	Overload (auto-calibrated or can be set)
	Transient surge
	Under voltage
	Over voltage
	Pump stalled
	Short circuit
	Phase loss (incoming & outgoing)
	Phase reversal
	Pump shaft anti rust protection
Other Technical Data	
Permissible ambient temperature	-5 to +50 deg C
Degree of protection	IP 55

PRODUCT RANGE

Part Code	Model	Voltage	PHASE	Current I (A)	Number of Pump	Dimensions			Panel Protection	Weight [kg]
						L	W	H		
98719402	GIDPC 1 Pump, 3 Phase, 8 A, Auto	380 - 415	3	Up to 8 AMPS	1 W	225	300	100	IP 55	3
98719406	GIDPC 1 Pump, 3 Phase, 12 A, Auto	380 - 415	3	Up to 12 AMPS	1 W	225	300	100	IP 55	3
98719408	GIDPC 1 Pump, 3 Phase, 16 A, Auto	380 - 415	3	Up to 16 AMPS	1 W	225	300	100	IP 55	3
99210628	GIDPC 2 Pump, 3 Phase, 8 A, Auto	380 - 415	3	Up to 8 AMPS	1W+1S	320	420	138	IP 55	5.5
99210629	GIDPC 2 Pump, 3 Phase, 12 A, Auto	380 - 415	3	Up to 12 AMPS	1W+1S	320	420	138	IP 55	5.5
99140817	GIDPC 2 Pump, 3 Phase, 16 A, Auto	380 - 415	3	Up to 16 AMPS	1W+1S	320	420	138	IP 55	5.5

For all pumps, electrical supply is 1 phase 220 Volts AC, 50 Hz

GIDPC Pro

1 PHASE, 1 PUMP UP TO 15 A

GIDPC PRO is a Digital Pump Controller, which is easy to use, programmable device for single phase pumps (monoblock or submersible). It can be used to control the pumps up to 15 Ampere.

TYPICAL APPLICATIONS

- GIDPC PRO 1 Pump – 1 Phase is very useful in water and wastewater applications, be it storm water, sewage, rain water reuse, irrigation, water supply or pressure boosting. It is an ideal choice in residential, industrial or institutional segments where water and energy conservation are of utmost importance.

KEY FEATURES

- Pressure control via pressure transmitter for pressure boosting application
- DIP switch settings to make it suitable for different applications like water supply, drainage or pressure boosting
- Dry run protection without Float switch
- Auto/manual switch with screen lock in AUTO mode
- Dynamic LCD screen for pump running and tank/pit level status
- Protect the pump against various faults (Overload, under voltage, over voltage etc.)
- Push button calibration for all parameter settings
- Pump accumulative running time
- Motor stalled & Transient surge protection
- RS485 Communication (MODBUS RTU Protocol)
- Start and Stop the pump based on feedback received from Float or pressure switch



TECHNICAL SPECIFICATIONS

Rated input voltage	AC 220 V / 50 Hz / Single Phase
Rated output current (amperes)	1.5 to 15 A
Trip response time of overload	5 sec - 5 min.
Trip response time short circuit	Less than 0.1 sec
Trip response time of under / over voltage	Less than 5 sec
Trip response time of dry run	6 sec (Default value; can be adjusted)
Recovery time of under / over voltage	5 min. (Default value; can be adjusted)
Recovery time of overload	30 min. (Default value; can be adjusted)
Permissible ambient temperature	-5 °C to 50 °C
Degree of protection	IP 54
Unit dimensions (L X W X H)	280 X 280 X 130 mm

PRODUCT RANGE

Part Code	Model	Voltage	Current I (A)	Number of Pump	Dimensions			Panel Protection	Weight [kg]
					L	W	H		
99807102	CP 1P 1PH 15A AUTO GIDPC PRO	1X220 V	1.5 to 15 Amps	1	280	280	180	IP 54	3

NEED SERVICE FOR GRUNDFOS PRODUCTS & SOLUTIONS USE GRUNDFOS SmArt Serv APP

Being the world's largest pump manufacturer, we are always committed to delivering service excellence to our customers. In an endeavour to providing prompt service, we have come up with an intelligent solution - the Grundfos SmArt Serv app. It is the quickest way of getting service support for Grundfos products and solutions.



SmArt Serv

With SmArt Serv App You can :

- Find the nearest service provider
- Track the status of service requests
- Escalate late responses
- Get a service report/quotation for spare parts
- Provide feedback on service quality



Download this
app to know more



WANT TO BE THE BEST INSTALLER IN TOWN ?

Grundfos Academy is a free digital training tool and information platform that keeps you abreast of the latest developments within Grundfos and the pump industry. Once you sign up, you have free access to the entire Grundfos Academy online training platform, tailored specifically to your needs.

This easy to use online tool offers you training videos, downloadable presentations and in-depth articles you can work through at your own pace on your smart-phone, tablet or computer.

Enter the Grundfos academy or visit <https://in.grundfos.com/ecademy.html>

Disclaimer

This selection booklet and Maximum Retail Price List is valid from 01.01.2020 till the next revision and supersedes all earlier released / issued booklets.

However, the Company reserves the right, at its discretion, to change, modify, add or remove portions of this booklet without prior intimation. Please check with the company periodically for changes, if any.

All reasonable care has been taken to ensure the accuracy of the contents of this material, however, GRUNDFOS Management A/S and/or Grundfos Pumps India Private Limited shall not be liable for any loss whether direct, indirect, incidental or consequential arising out of the use of or reliance upon any of the content of the material. It would be advisable for you to seek professional advice from Grundfos when recommending a product for any specific purpose.

All Rights Reserved. No part of this booklet may be reproduced in any form or by any means without written permission from Grundfos Pumps India Pvt Ltd.



WORLD OF GRUNDFOS IN YOUR HAND



THE GRUNDFOS PRODUCT CENTER ONLINE TOOL LETS YOU SIZE PUMPS, BROWSE THE GRUNDFOS PRODUCT CATALOGUE, FIND APPROPRIATE REPLACEMENT PUMPS AND FIND PUMPS FOR HANDLING SPECIFIC LIQUIDS

Search in the way that meets your needs by application, pump design or pump family.

Experience faster sizing thanks to a new intelligent "Quick Size" function.

Documentation includes pump curves, technical specs, CAD drawings, available spare parts, installation videos, and much more.

Optimised for your PC, tablet or smartphone.

As a registered user you will have access to saved preferences, products and projects and recent browsing history.

Scan and enter the Grundfos Product Center, or visit www.product-selection-grundfos.com

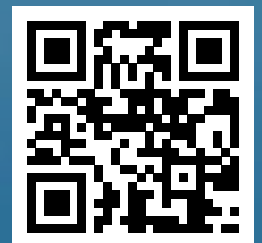

GRUNDFOS 



Grundfos Pumps India Private Limited

Head Office

118, Rajiv Gandhi Salai,
Thoraipakkam, Chennai,
Tamilnadu, Pin - 600097

Manufacturing Plants

Chennai:

118, Rajiv Gandhi Salai,
Thoraipakkam, Chennai,
Tamilnadu, Pin - 600097

Ahmedabad:

Block 198/3-4, Dantali Industrial Estate,
Near Lapkamn Gam,
Gota-Vasdard Road, Dantali,
Gandhinagar, Gujarat, Pin - 382721

Contact Us

Toll Free Number: 18001022535

Sales: contact.india@sales.grundfos.com

Service: serviceindia@grundfos.com

Grundfos Pumps India Private Ltd.
118 Rajiv Gandhi Salai,
Thoraiakkam, Chennai 600 097
Toll Free Number: 18001022535
E-Mail: oneoffice.india@sales.grundfos.com
www.grundfos.in