

S150 series

Ø150mm Large Sized Warning Lights

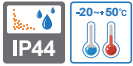

S150R



S150R-FT



S150RLR



S150RLR-FT



Common Specifications(S150R/ S150RLR)

- Features highly durable housing made of corrosion-proof stainless steel (STS)
- Mounting bracket allows convenient installation in case of XXX-FT type
- Revolving speed : 120-140RPM
- Materials : Lens-PC, Housing-STS, Reflector-PC/ Heat resistant ABS, Mount Bracket-STS
- Ambient operating temperature : -20°C to +50°C
- Protection rating : IP44



S150R/ S150R-FT Bulb Revolving Warning Lights

- High power light bulb and large rotating reflector enables superior visibility from a distance
- Certificates : CE Compliant

Model number	Voltage	Current	Bulb			Certificates	Weight	Color
			Spec	Standard	Parts no			
S150R S150R-FT	DC12V	1.155A	12V15W	G23 15S	17	CE	0.85kg	• R-Red
	DC24V	0.766A	24V15W	G23 15S	18		0.85kg	• A-Amber
	AC110V	0.204A	12V15W	G23 15S	17	-	1.24kg	• G-Green
	AC220V	0.102A	12V15W	G23 15S	17	-	1.24kg	• B-Blue



S150RLR/ S150RLR-FT LED Revolving Warning Lights

- Excellent omni-directional visibility with LED light collecting system and special multifaceted reflector

Model number	Voltage	Current	Certificates	Weight	Color
S150RLR S150RLR-FT	DC12V	0.422A	-	0.77kg	• R-Red • A-Amber • G-Green • B-Blue
	DC24V	0.266A		0.77kg	
	AC110V	0.082A		1.16kg	
	AC220V	0.041A		1.16kg	



Technical Diagram

(Units : mm)

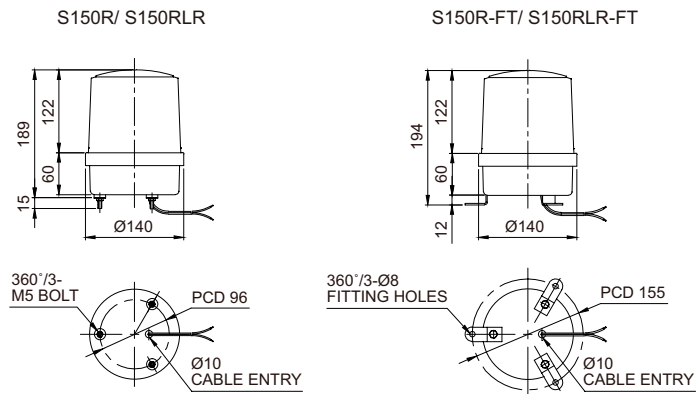

Wiring Instructions

- External power line standard : UL1015 AWG18(0.75sq)×2C 400mm
- DC Type : Black output line is negative(-)



Ordering Specification

S150R	-	220	-	R
[Model number]		[Voltage]		[Color]
• S150R • S150R-FT • S150RLR • S150RLR-FT		• 12-DC12V • 24-DC24V • 110-AC110V • 220-AC220V		• R-Red • A-Amber • G-Green • B-Blue

